

BASICS OF THE ENGINEERING DRAWING

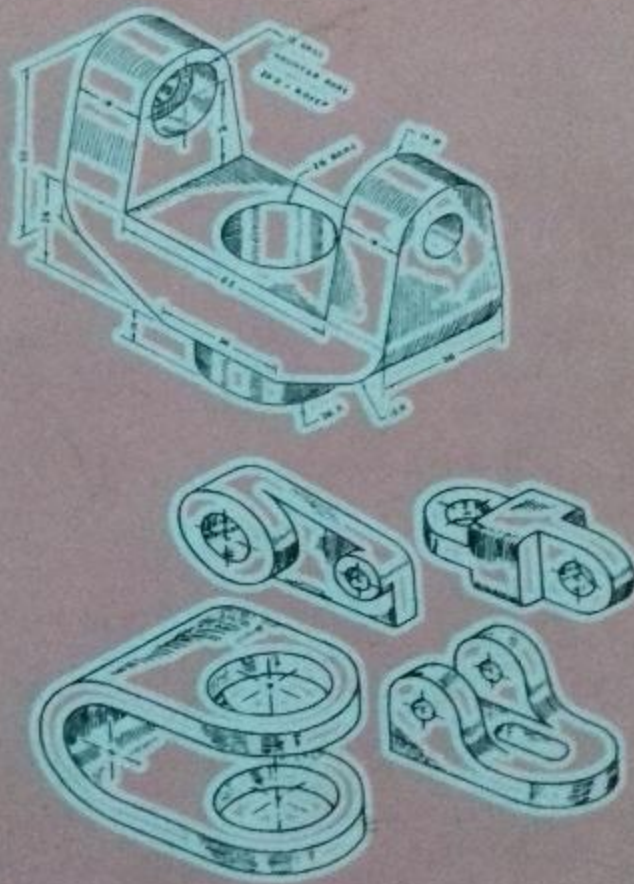

ZAHID AHMAD SIDDIQI



Help Civil Engineering Publisher, Lahore, Pakistan

Published in 2011 by

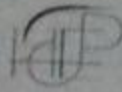

Help Civil Engineering Publisher
97-C1, NESPAK Colony, Lahore

Zahid Ahmad Siddiqi

Basics of the
Engineering Drawing

ISBN 978-969-8633-06-6

This book was composed and produced by Zahid Ahmad Siddiqi, Professor, Civil Engineering Department, Lahore and Published by Help Civil Engineering Publisher, Lahore.

Copyright © Zahid Ahmad Siddiqi 2011

All rights are reserved. No part of this publication may be reproduced, stored in a retrieval system, or transmitted in any form or by means of electronic, mechanical, photocopying, recording or otherwise, without the prior written permission of the authors.

Basics of the
Engineering Drawing

ZAHID A. SIDDIQI

Professor

Civil Engineering Department

University of Engineering and Technology

Lahore

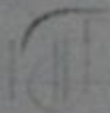

Help Civil Engineering Publisher

97 C-4, NESPAK Colony, Lahore

In the Name of Allah, the Most Beneficent, the Most Merciful

Recite in the Name of the Allah, Who had created (*Al-Quran*)

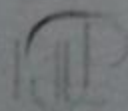

© Copyright by Zahid Ahmad Siddiqi
All Rights Reserved

ABOUT THE AUTHOR

Zahid Ahmad Siddiqi, Ph.D., is Professor in Civil Engineering Department of University of Engineering and Technology, Lahore. He is author of previous edition of this book published in 1992 besides various editions of four more books on the subjects titled "Steel Structures", "LRFD Steel Design Aids", "Concrete Structures, Part-I" and "Concrete Structures, Part-II". He has teaching, research and practical design experience of almost 27 years. He has vast experience of teaching to Undergraduate and Graduate Students of Civil Engineering. He is actively involved in field design of sizeable concrete and steel structures.

CONTENTS

Preface	vi
Chapter 1 - Introduction	1
1.1 The Subject	1
1.2 Drawing Instruments	3
Chapter 2 - Use of Instruments and Lettering	13
2.1 Classification of Lines	13
2.2 Sharpening the Pencil	15
2.3 Horizontal and Vertical Lines on the Board	15
2.4 Fixing the Drawing Sheet	18
2.5 Border Lines and Seal	19
2.6 Measurements in Fractions of an Inch	20
2.7 Lettering on the Drawing	21
2.8 Methods of Dimensioning	24
2.9 Applied Geometry	26
2.10 Hints for Good Linework Problems	34
Chapter 3 - Orthographic Drawing	41
3.1 Faces of Object	41
3.2 Planes of Projection	42
3.3 Space Dimensions	42
3.4 Dimensions Appearing in the Views	43
3.5 Perspective Projection	43
3.6 Orthographic Projection	44
3.7 Lines to Form a View	45

3.8 Three Orthographic Views	46	
3.9 Classification of Surfaces	47	
3.10 Arrangement of Views	51	
3.11 Hidden Features	56	
3.12 Center-Lines and Precedence of Lines		59
3.13 Order of Drawing	59	
3.14 Transferring Dimensions Inbetween the Views		
3.15 Freehand Sketching	63	
3.16 Models	64	
3.17 Symbols Used in Orthographic Drawing		65
Problems	70	
Chapter 4 - Sectional Views		79
4.1 Introduction to Sections		79
4.2 Types of Sections	85	
4.3 Details Behind the Cutting Plane		93
4.4 Parts Not Sectioned	93	
4.5 Reading Orthographic Views		97
Problems	98	
Chapter 5 - Pictorial Sketching		101
5.1 Isometric Sketching	101	
5.2 Perspective Sketching	103	
5.3 To Draw a Two-Point Perspective		108
Problems	112	
Chapter 6 - Building Drawing		113
6.1 Basic Definitions	113	
6.2 Comparison Between Model Drawing and Building Drawing	121	
6.3 Drawing of a Boundary Wall	126	
6.4 Typical Features Present in a Building		127
6.5 Drawing of a Building	132	
6.6 Considerations for Architectural Design of a House	141	
6.7 Adjusting Plans of Ordinary Buildings		145
6.8 Types of Civil Engineering Drawings		146
Problems	150	
Chapter 7 - Intersection and Development of Surfaces		151
7.1 Surfaces	151	
7.2 Common Types of Surfaces		151
7.3 Intersection of Surfaces		153
7.4 Development of Surfaces		156
Problems	160	

PREFACE

Drawing is one of the basic subjects of Engineering and there is no challenge to its very diversified importance and use. No single book is available in our country to explain the basic concepts and principles to the students of degree and diploma classes written in a local pattern. This book is the first effort to compensate this deficiency and the matter presented is based on experience of teaching this subject to the undergraduate classes for many years combined with the practical needs and requirements. Due to the financial constraints, all the figures were drawn by the principal author himself besides all the typing work which may have restricted the standard of the presentation.

The authors feel that this first edition may have many areas needing improvement both in terms of the concepts and the language. The readers are highly encouraged to point out any such improvement and to submit their suggestions which will be properly incorporated in the future editions. The authors are thankful to M/s Help Civil Engineering Publisher Lahore for printing this book in a presentable form.

AUTHORS

CHAPTER NO.1

INTRODUCTION

1.1 THE SUBJECT:

Engineering drawing, also called technical drawing and engineering graphics, is the graphical representation of shape of any physical object which may be a part of a machine, a building, a dam, or any other complicated structure. The shape of some simple objects like spheres, cubes, cylinders, etc., may be described in words and sentences but ordinary language fails for complicated objects. Even if a thick book is written to describe the shape of a building, the reader will not be able to conceive the exact shape of that building with all its minor details. It can be safely said that it is almost impossible to describe the shape of an object in words and hence only three methods are left for the purpose namely camera photographs, models and drawings.

Camera photographs can only be used to communicate the shape of existing structures but not the shape or design still in the mind of the designer. Further these photographs do not show all the inner details and actual dimensions are not communicated. Models, usually made up of wood, polystyrene, soap, plastic, etc., are perhaps the best tool for description of the shape but these are generally used for explaining finished outer shapes of the structures to non-engineering persons. Sometimes models, made smaller in size, are also used to carry out performance study of bigger structures like canals, dams and turbines. Models require much more skill and time for their creation necessitating relatively more skilled persons employed for longer periods; also more space is required in offices for their storage. Hence, cost to describe the shape with models is usually much greater and this method for shape-communication is not generally used except only in special cases.

The easiest way left to describe an object is to make drawings, simply lines are drawn on a piece of paper

according to certain fixed rules. The advantages of engineering drawing are as follows:

1. Complete shape of the object is represented.
2. Inner details may also be shown.
3. Actual dimensions may be communicated.
4. Lesser time is consumed in making the drawings.
5. Relatively lesser training is required for making and understanding the drawings.
6. Lesser space is consumed for their storage.
7. Drawings may easily be transported from one office to the other. Further these are easy to be handled at the site.
8. Once drawings are made, as many copies of these as required may easily be obtained.
9. Lesser cost is involved in making drawings.

Consider, for example, the construction of an ordinary house. First an architect will design the building architecturally meaning that sizes of all the component parts (like rooms, stores, kitchen, bathrooms, and almirahs) and their relative positions for easy and comfortable living are decided. The ideas, called design, are represented in some drawings. These architectural drawings are then passed over to civil engineer who design the building structurally meaning that the behaviour of the building under the worst possible loads is studied and thicknesses and materials of construction are specified for beams, roof-slabs, walls and floors, etc. A civil engineer has to read the architectural drawings and, after some calculations, he has to make drawings to represent his design. No matter how knowledgeable an engineer may be concerning the highly complex technical and scientific aspects of his profession, without a command of the engineering drawing he would be completely ineffective simply because he would fail miserably in understanding the designs of others and in transmitting his designs to others. A site-engineer reads the drawings supplied to him and accordingly carries out the construction exactly as originally conceived by the engineer.

From the above example, it is clear that the only way of communication among the engineers is drawing with the help of which they can understand other engineers and express themselves. Hence it may safely be said that engineering drawing is the language of the engineers. Engineering drawing may also be defined in another way, that is, it is a system of communication in which ideas are expressed exactly, information is conveyed completely and unambiguously, and even the most complicated shapes are specifically described.

1.2 DRAWING INSTRUMENTS:

In selecting instruments for drawing, secure the best you can afford. With reasonable care a set of good instruments will last a life-time, whereas poor ones will cause disturbance even in the start and will be unusable after a very short period.

1. Drawing Board

The drawing surface may be the drafting table top itself or a separate board. Drawing board is a rectangular wooden piece with two short and two long sides about 2.75' x 2' in size. One short edge is especially made straight and is called the working edge. This edge should be tested with an already tested T-square blade and must be perfectly straight.

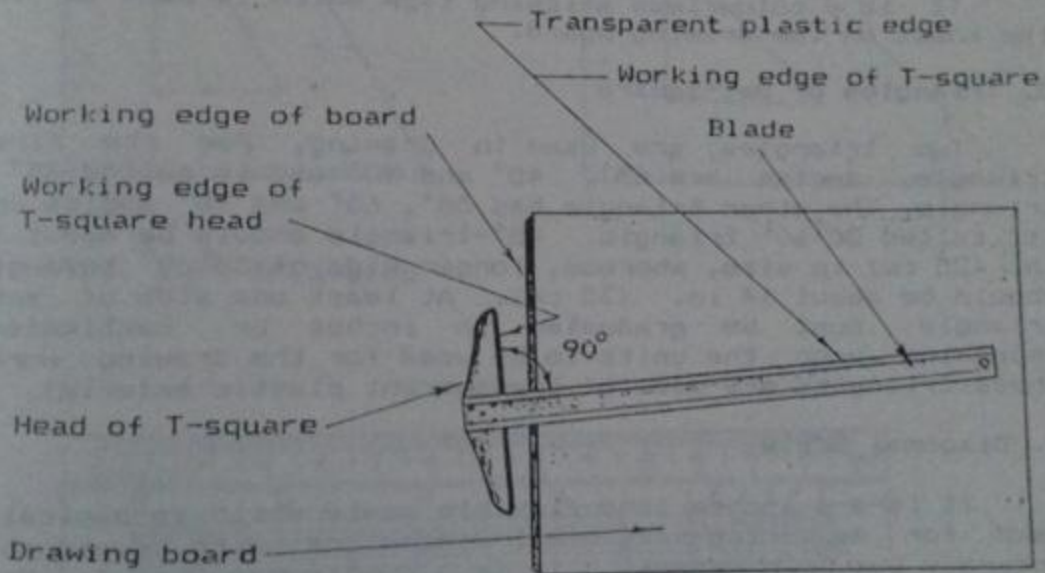

Fig. 1.1 Drawing Board and T-square

.. T-Square

The T-square is composed of a long strip, called the blade, fastened rigidly at right angle to a shorter piece, called the head or stock. The upper edge of the blade and the inner edge of the head are working edges and must be

straight. Transparent edge is recommended for top edge of the blade since it permits the working person to see the drawing underneath. T-square may be made up of wood, plywood or plastic but its size must be equal to the board size (called imperial size).

3. Drawing Sheet

Imperial size (30" x 22") sheet of better quality should be used. In general, paper should have sufficient grains or teeth against which lead of the pencil may work, colour of the paper should be agreeable to the eye, the sheet should provide a hard surface not easily grooved by the pencil and erasing qualities of the paper should be good. Drawing on a good quality sheet is always easier.

4. Drafting Tape (Scotch Tape)

It is a colourless sticking tape which is used to fix the sheet on the drawing board.

5. Triangles or Set-Square

Two triangles are used in drawing. For the first triangle, angles are 45° , 45° and 90° and is called 45° -triangle. The other triangle has 30° , 60° and 90° angles and is called 30° - 60° triangle. 45° -triangle should be about 10 in. (25 cm) in size, whereas, longer side of 30° - 60° triangle should be about 14 in. (35 cm). At least one side of each triangle must be graduated in inches or centimeters depending upon the units to be used for the drawing work. These triangles are made of transparent plastic material.

6. Diagonal Scale

It is a 6 inches long flexible scale which is basically used for measuring very small dimensions with reasonable accuracy but, in general, it is a multipurpose scale. With decimal diagonal scale in inch units, measurements may be taken upto second decimal place.

7. Compasses and Dividers

Compass is an instrument with the help of which we can draw circles, it consists of two arms hinged together at one end. One of the arms holds a metallic needle at the free end while the other arm may hold another needle, lead, pen, or a lengthening bar. Bow-type compass with opening and closing screw inbetween the two arms is preferable because the compass may be opened exactly and further the opening is not

disturbed while drawing the circle. If both ends into needle points, the instrument is called a divider. At least

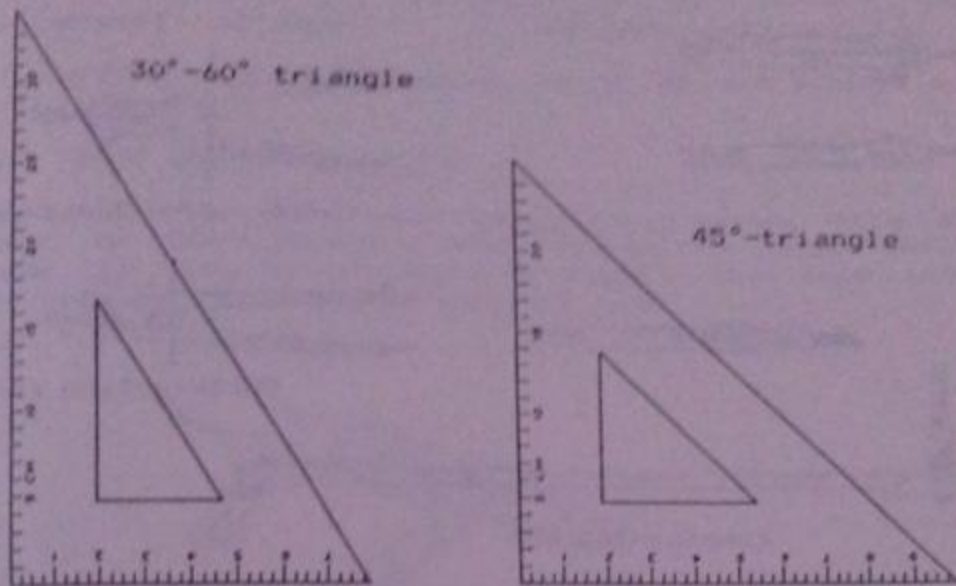

Fig. 1.2 Triangles



Fig. 1.3 Decimal Diagonal Scale in Inch Units

two compasses, one small and one large, and one divider should be obtained with all the accessories like extra

leads, extra needles, lengthening bar, and small screw tightener. The set of compasses and dividers is commonly available in the form of a drawing instrument box.

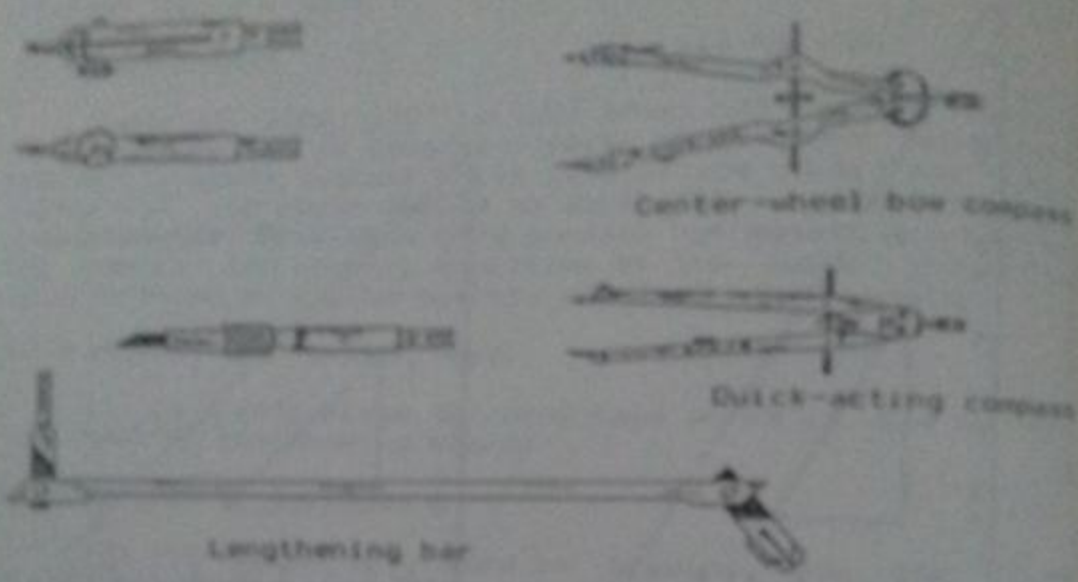

Fig. 1.4 Contents of Drawing Instrument Set

8. Pencils

The basic instrument for drawing is the graphite lead

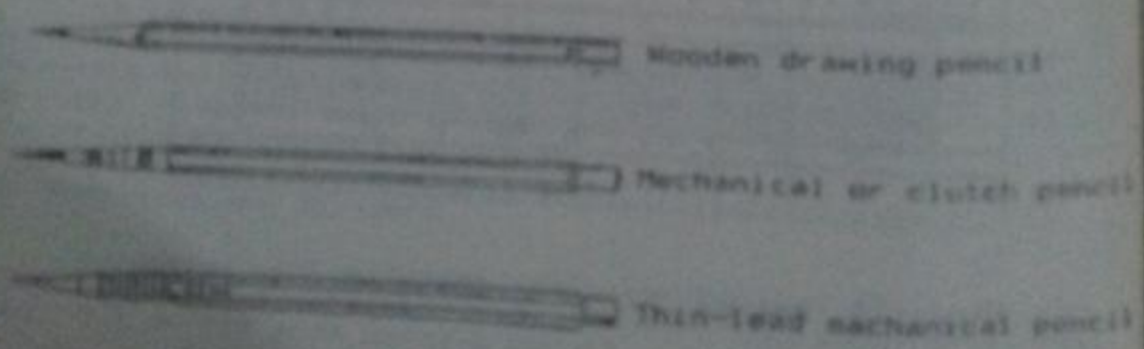

Fig. 1.5 Drawing Pencils

11. Erasing Shield

It is a thin metallic plate with perforations of various shapes and is used to remove extra lines after the completion of a drawing without disturbing the required lines.

12. Towel or Brush

During drawing work, frequent cleaning of the sheet and the instruments is needed. Hence, a towel or a brush should always be available.

13. Triangular Scale

This instrument is triangular in shape having six edges and usually two scales are provided over each edge, one starting from the left and the other starting from the right.

The scales (in F.P.S. units) available in triangular shape are generally of three types.

a) Mechanical Engineer's Scale

These scales are used to draw the object on the actual size, double size, half size, quarter size, or eighth size. As usually smaller dimensions are involved in machine drawing, bigger divisions represent inches which are then subdivided into fractions.

b) Civil Engineer's Scale

This scale is graduated in the decimal system and the set of these scales is as follows:

10 , 20 , 30 , 40 - - - - -

On a 10-scale, inch is divided into 10 equal parts, one part is generally considered to be equal to 1 foot in survey maps. In other words, 10 ft of the actual structure will be shown by 1 inch of the line on the drawing sheet.

Mechanical Engineer's and Civil Engineer's Scales are not used for the building drawing.

c) Architectural Scale

Full, Half, Quarter, Eighth - - - - -
or 1 , 1/2 , 1/4 , 1/8 , - - - - -

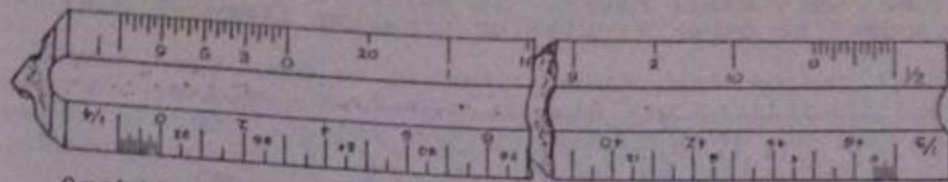

Architectural triangular scale

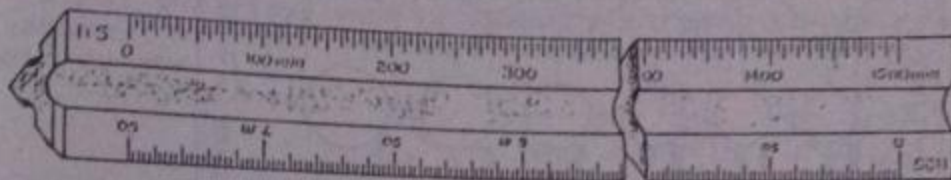

Metric triangular scale

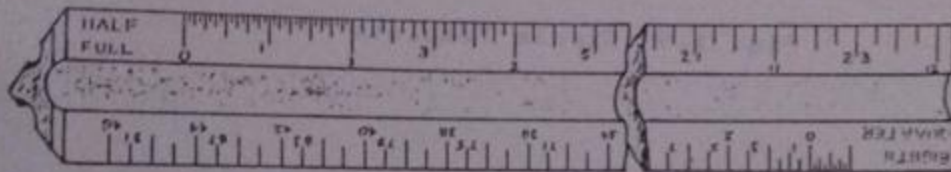

Mechanical engineer's triangular scale

Fig. 1.8 Triangular Scales

Architectural scale is actually an inch-foot scale and full scale here means that one foot of the structure is represented by one inch of the drawing line, size is reduced 12 times before drawing. Similarly half scale means that one foot of the structure is represented by half inch of the drawing line, reduction factor being 24.

Architectural triangular scale should be obtained for building drawing.

14. Set of Circles (Circle Template)

This is a thin sheet of plastic having circular openings of various sizes and is especially useful to draw

circles of very small radii. It may also be used to draw curves tangent to other circles or straight lines.

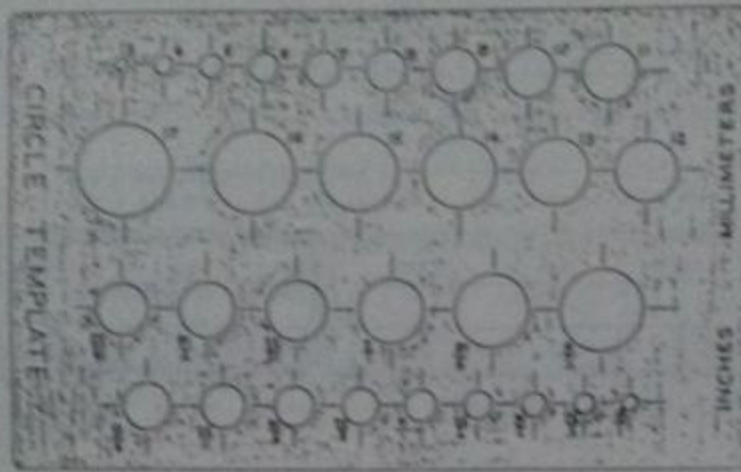

Fig. 1.9 Circle Template

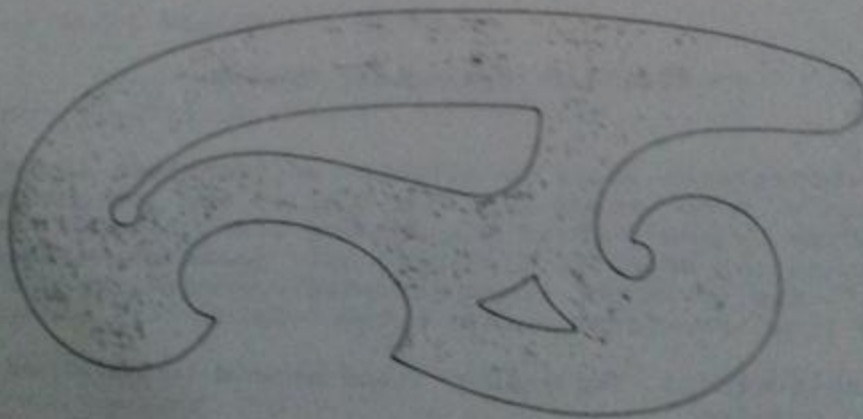

Fig. 1.10 Irregular or French Curve

15. French Curves

These are made of plastic sheets with edges lying in irregular curves. Suitable curves may be fitted for the already plotted points and freehand curves may be changed into smooth curves.

16. Flexi-Rod

It serves nearly the same purpose as the French curves do. First the flexi-rod is shaped according to the required curvature, it then retains its shape and is used to draw smooth curves.

CHAPTER NO.2

USE OF INSTRUMENTS AND LETTERING

2.1 CLASSIFICATION OF LINES

Lines may be classified according to their thickness, darkness and shape.

2.1.1 Classification According to Thickness

a) Very thick lines drawn with chisel-shaped pencil, Fig. 2.2, are used to show reinforcing steel bars and position of beams etc. in structural working drawings, see Fig. 2.1 (A).

b) Relatively thicker lines drawn with cone-shaped pencil, Fig. 2.2, are used to show ground level in elevation of buildings, plastered surfaces of walls in plans, etc., see Fig. 2.1 (B).

c) Lines of common thickness show usual features of the object, see Fig. 2.1 (C).

d) Thin lines are used for center-lines, construction lines, extension lines, and dimension lines, etc.

2.1.2 Classification According to Darkness

Line of a given thickness may be dark and bright or it may be dim depending upon grade of the pencil and the pressure applied.

a) Thick and common lines should be of greater darkness and brightness keeping their thickness in the required range. Generally try for greater brightness increases the thickness of the line.

b) Center-lines, extension lines and dimension lines should be of moderate darkness, see Fig. 2.1 (D).

c) Construction lines and guide lines should be very light or dim, just visible to the working person.

2.1.3 Classification According to Shape

a) Full line of common thickness shows visible outline of the object, Fig. 2.1 (C); H-pencil is generally used for the purpose.

b) Full lines of lesser thickness and brightness are used as extension and dimension lines, see Fig. 2.1 (D); 2H-pencil may be used.

c) Full lines of very dim quality, drawn with 4H-pencil, are used as guide-lines and construction lines.

d) Dotted line consists of a series of dots, see Fig. 2.1 (E), and is not generally used in engineering drawing because lot of time is consumed in drawing a dotted line.

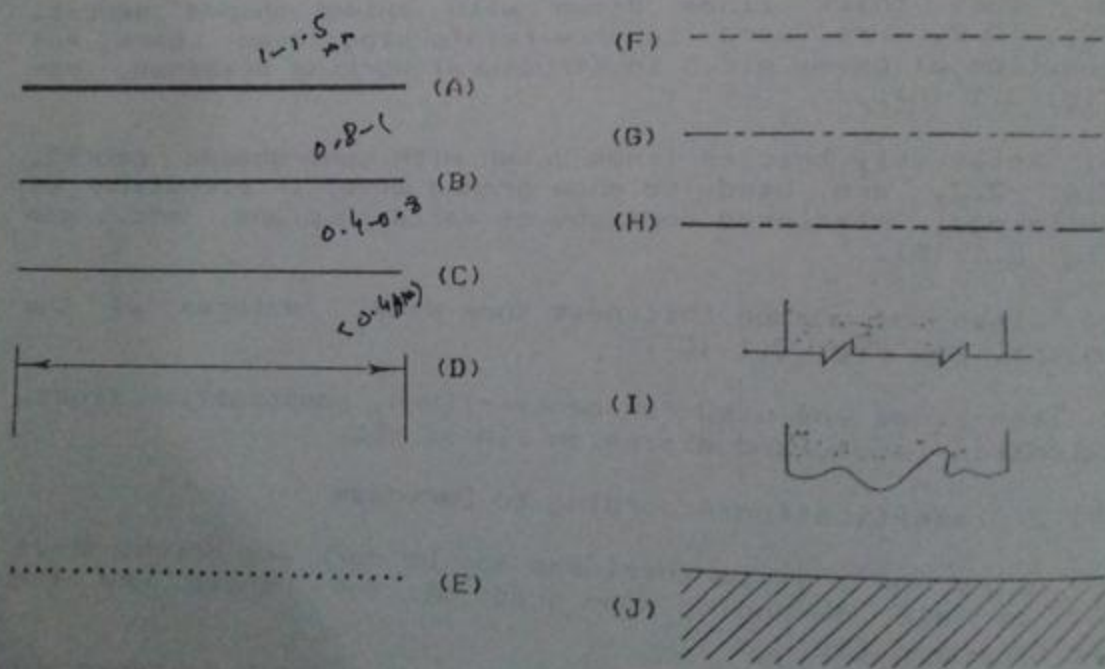

Fig. 2.1 Types of Lines.

e) Dashed line consists of a series of dashes as shown in Fig. 2.1 (F). The dashes should approximately be equal in length and also the gap inbetween two dashes should roughly be equal. Where dashed lines are in continuation of full lines, these should be started from a gap, otherwise, these should be started by a dash. These lines indicate hidden outlines in mechanical drawing but, in civil engineering drawing, these lines, in plan, show the features above the horizontal cutting plane like beams, sunshades and ventilators.

f) Center-lines consist of series of alternate long and short dashes, as in Fig. 2.1 (G). These lines are used to locate centers of circular parts and axes of cylindrical features.

g) Cutting plane symbol is series of alternate one long and two small dashes using relatively thicker line, see Fig. 2.1 (H).

h) Break lines have different shapes, two of which are shown here, see Fig. 2.1 (I). These are used to end a part of the structure to indicate the continuity of the structure in the same pattern.

i) Section lining or cross-hatching consists of lines drawn at 45° angle with a uniform spacing of 1/16" to 1/8", as in Fig. 2.1 (J). It is used to indicate solid portions in section.

Dashed lines, cutting plane symbol and break lines are imaginary lines and are usually extended from the views.

2.2 SHARPENING THE PENCIL

Lead of the pencil should always be kept sharp, only a sharp lead is capable of producing clean black lines that sparkle with clarity. For wooden pencils, lead is opened approximately 1/2" in length and then required shape of the lead is made over a sandpaper pad. For cone-shaped lead, pencil is rotated in the hand while sharpening and a very fine cone is made having at least 3/8" length and ending in a perfect wedge point. For chisel-shaped lead, grinding of the lead is done from the two opposite sides and for lead to be used in a compass, grinding is done only from one side.

2.3 HORIZONTAL AND VERTICAL LINES ON THE BOARD

For right-handers, the drawing board should always be placed in such a position so that its working edge is on the

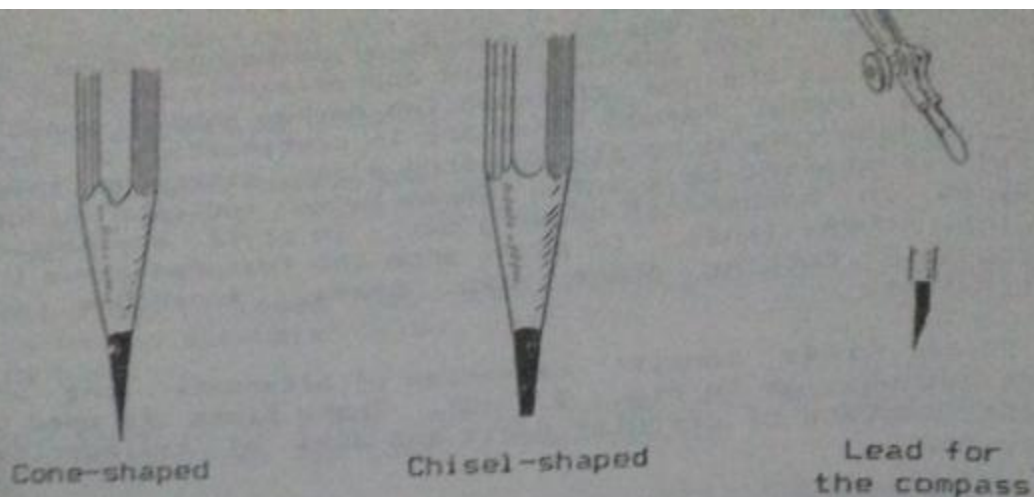

Fig. 2.2 Lead Points.

left of the working person. This working edge of the drawing board serves as a reference vertical line. All vertical lines on the drawing sheet should be parallel to the working edge and all the horizontal lines should be perpendicular to it. The head of the T-square can be slid over the working edge of the board as shown in Fig. 2.3 (A). When the working edges of the board and head of the T-square are in close contact throughout the length, the working edge of the later becomes vertical. As blade of the T-square is at right angle to the head, the working edge of the blade comes in the horizontal direction when working edge of the head is made parallel to the reference vertical edge. By sliding the T-square upwards or downwards on the board, a set of horizontal lines may be drawn. Following steps may be taken while using a T-square:

- i) Only one point is marked on any vertical line on the sheet from where horizontal line is to be drawn. It is not a good practice to mark points at the two ends which are later on joined with any straight edge.
- ii) While using a T-square, the working edges of the board and head of the T-square must be in close contact throughout the contact-length. To draw a horizontal line, hold the head of the T-square with the left hand, as shown in Fig. 2.3 (A), and apply a slight but uniform lateral pressure over the T-square towards the board. Slide the left hand until the working edge of the blade just passes through the already

marked point. Change your hold so that fingers remain on the T-square and the thumb is placed on the board, making sure that the position of the T-square is not changed, Fig. 2.3

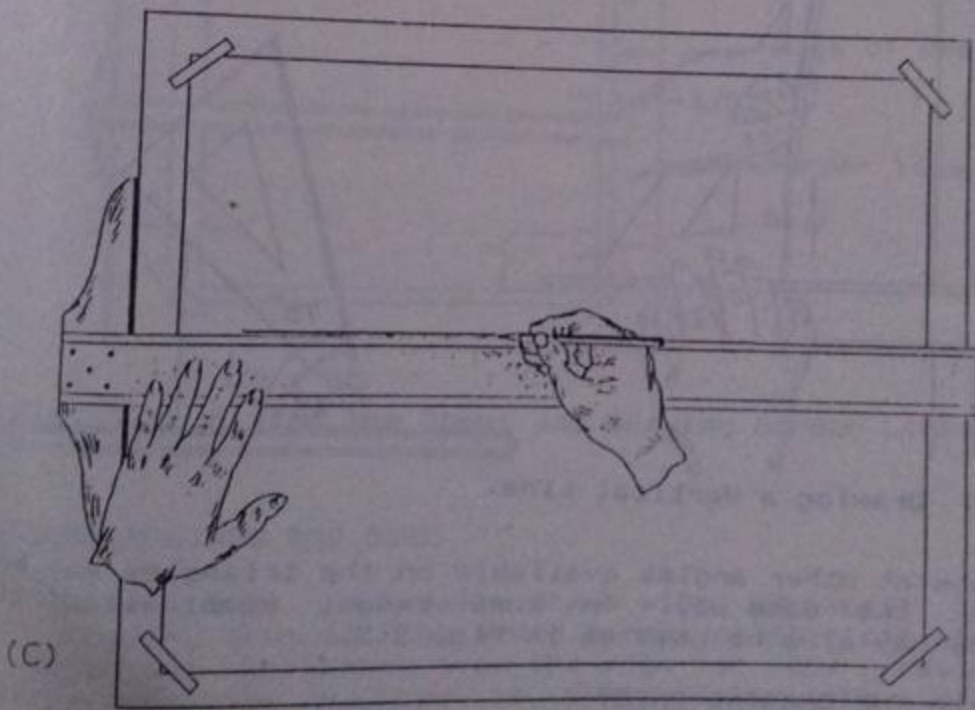
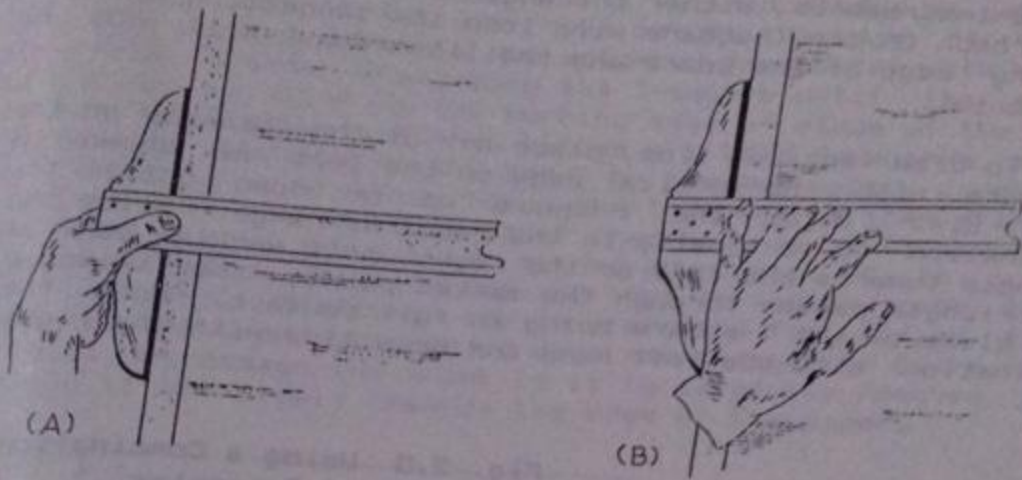

Fig. 2.3 Drawing a Horizontal Line.

(B). Draw horizontal line as shown in Fig. 2.3 (C) with the right hand.

iii) While sliding the T-square, the blade should be allowed to move freely. If it is touching with the right hand, notes or the instruments, either the angle of the T-square will be disturbed or the T-square will lose its connection with the working edge of the board and the lines drawn will not be horizontal.

To draw vertical line, place any of the triangle on the T-square with the vertical edge on the left as shown in Fig. 2.4. Slide the T-square up or down until the combination is vertically in the required range. Slide the triangle towards the left or the right until working edge of the triangle passes through the earked point, the triangle and blade of the T-square being in full contact. Hold the combination with the left hand and draw line with the right hand.

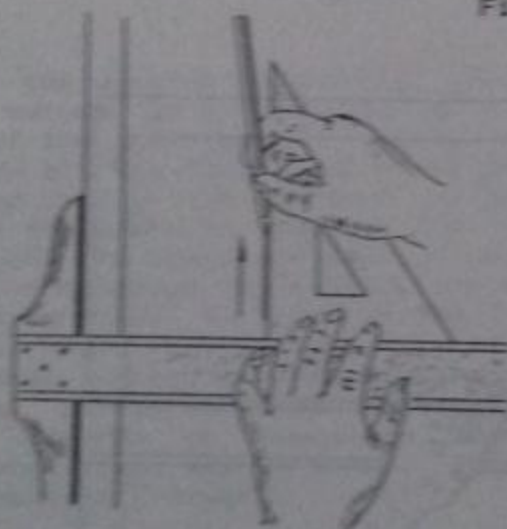
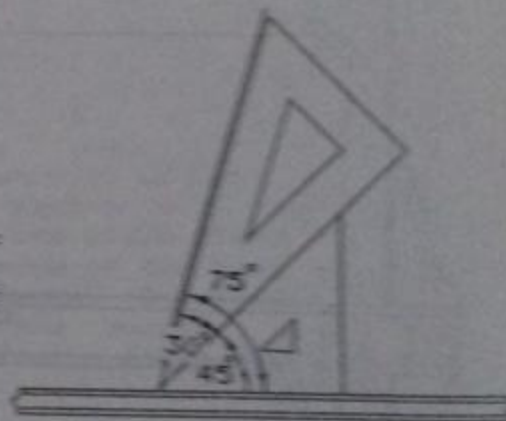

Fig. 2.4 Drawing a Vertical Line.

Fig. 2.5 Using a Combination of Triangles.



Lines at other angles available on the triangles may be drawn in the same way. In some cases, combination of triangles may also be used as in Fig. 2.5.

2.4 FIXING THE DRAWING SHEET

Drawing sheet should be fixed on the board in such a way that its upper longer side is truly horizontal. First

of all the sheet is placed on the board such that approximately equal spaces are left on all the sides. T-square is placed over the sheet and is held in the correct position with the left hand as described before, so that, its blade comes in a horizontal line. It is then slid up until its working edge comes very near to the top edge of the sheet. The drawing sheet is now adjusted from below with the right hand without disturbing the T-square until its top edge becomes parallel to the working edge of blade of the T-square. The T-square is then slid a little downwards and the sheet is fastened to the board on the two upper corners with the help of drafting tap. The T-square is then slid up and edge of the sheet is again checked. If it is exactly horizontal, the T-square is slid down until it is just above the bottom of the sheet and tape is applied over the lower corners. Drafting tap is preferred for fixing the sheet on the board because it does not damage the board and it will not damage the sheet if it is carefully removed by pulling it off slowly towards the edge of the paper.

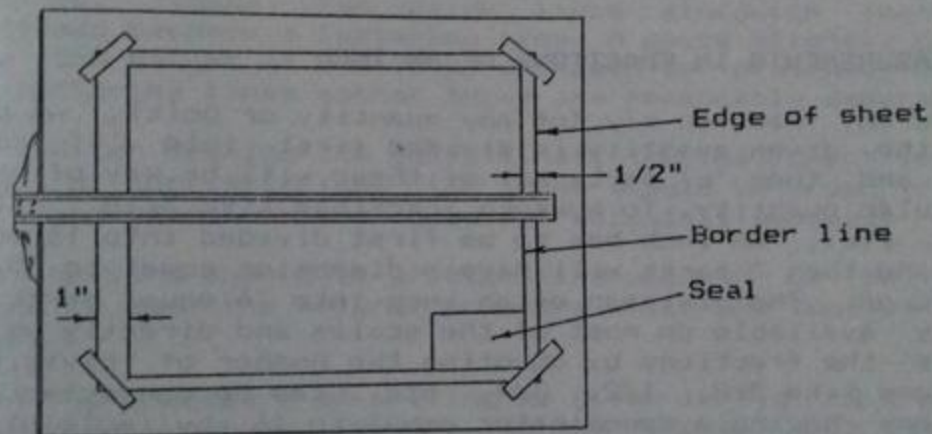

Fig. 2.6 Fixing the Sheet and Drawing Border Lines.

2.5 BORDER LINES AND SEAL

Border line is usually drawn with HB-pencil leaving 1/2" spacing from all the sides except on the left where it is kept one inch away from the edge for the reasons of binding of the drawings at the end in the official documents.

Seal or title is a block usually left at bottom-right corner of the sheet to have the following information:

i) Name of the department or the firm which is preparing the drawing.

ii) Name of the client for which the drawing is being prepared.

iii) Heading of the sheet showing the purpose and the name of the project for which the drawing is made.

iv) Scale used, date of drawing, drawing number, etc., are also mentioned.

v) Name and signatures of the designer, the checker, the draftman, the approving person, and the client in some cases.

The design of seal is always fixed for a particular organization and, in some cases, it is printed on the blank sheets.

2.6 MEASUREMENTS IN FRACTIONS OF AN INCH

By any fraction x/y (of any quantity or unit), we mean that the given quantity is divided first into 'y' equal parts and then 'x' parts out of these will be x/y of that particular quantity. To measure fractions like $3/16"$, $6/16"$, $8/16"$, etc., an inch has to be first divided into 16 equal parts and then 3 parts will have a dimension equal to $3/16"$ and so on. The division of an inch into 16 equal parts is usually available on most of the scales and directly we can measure the fractions by counting the number of divisions. Fractions like $3/8$, $1/2$, $3/4$, etc., can be converted into fractions having a denominator equal to 16 by multiplying the numerator and the denominator by an appropriate number.

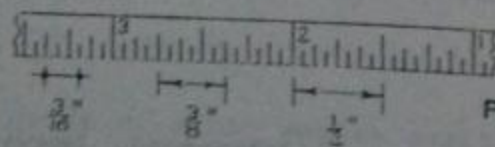
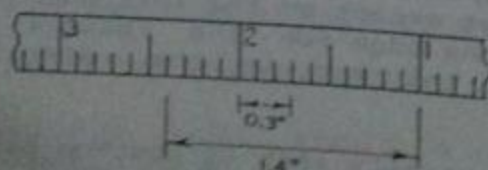

Fig. 2.7 Inch Divided into 16 and 16 Equal Parts.



The measurements upto first decimal place can be measured from those scales where an inch is divided into 10 equal parts. For example, 0.3" means $\frac{3}{10}$ " or 3 parts out of 10 parts of an inch; if we measure a length equal to 3 small divisions from that inch which is divided into 10 equal parts, it will be 0.3".

2.7 LETTERING ON THE DRAWING

Generally all the lettering on the sheet is carried out in capital letters and following points should be kept in mind while carrying out the lettering.

2.7.1 For writing letters, naturally upper and lower guide lines are required so that all the letters are of equal height and they are arranged in a single row. The guide lines should be thin upto such an extent that these are just visible to the working person; 4H pencil with much lesser pressure may serve the purpose. The spacing between two guide lines should be equal to the height of the letters required. These two guide lines along with the space in between becomes a lettering line. A space slightly greater than the height of the letters should be provided between two lettering lines so that these are reasonably separated.

2.7.2 After drawing the guide lines, no instrument is to be used for the lettering, the lines should be drawn freehand and the proportions should be approximately guessed.

2.7.3 Letters should be written firm with 'H' or 'HB' pencil depending upon the natural pressure which one applies on the pencil.

2.7.4 The procedure of writing as given in Fig. 2.9 must be followed without any change. In the figure, each letter is divided into different strokes and a graph is provided in the background for providing idea about the proportions of height and width. One stroke means a single fluent line drawn without releasing the pressure on the pencil in between. Each stroke is numbered to represent the order of strokes and the same order must be followed while carrying out lettering. Starting and ending points of the strokes are clearly marked by arrows. Always start from the tail and move towards the head. Starting or ending marks should not be placed for any stroke and no stroke should be doubled because, in this way, the line will become a multi-stroke line. If there is any mistake during lettering, erase whole of that letter and start again.

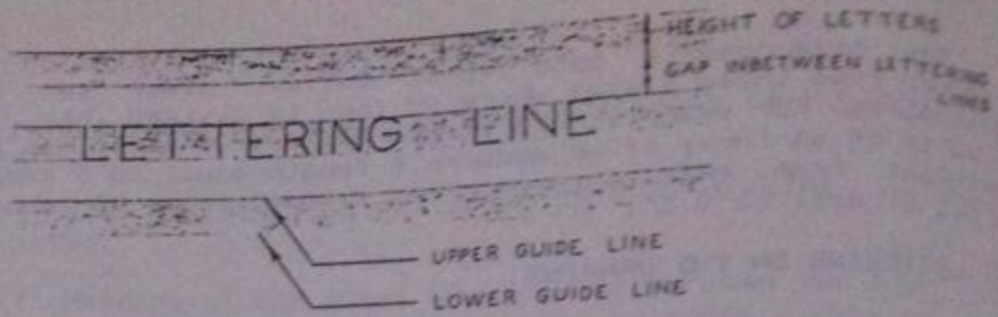

Fig. 2.8 Guide Lines for Lettering.

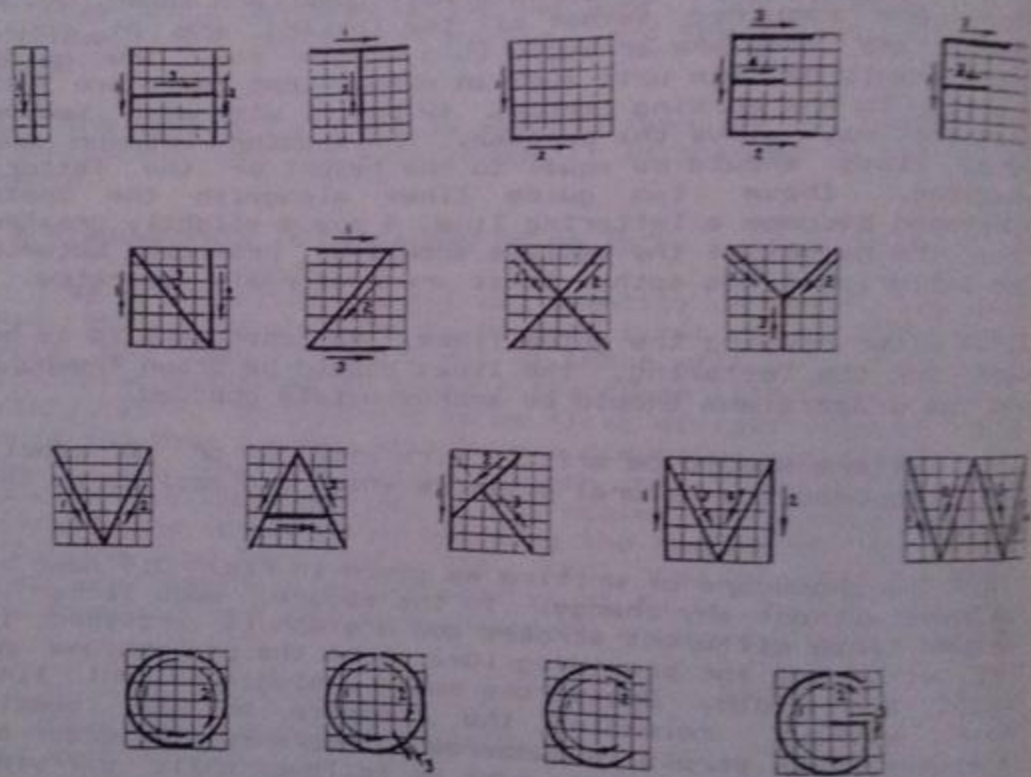
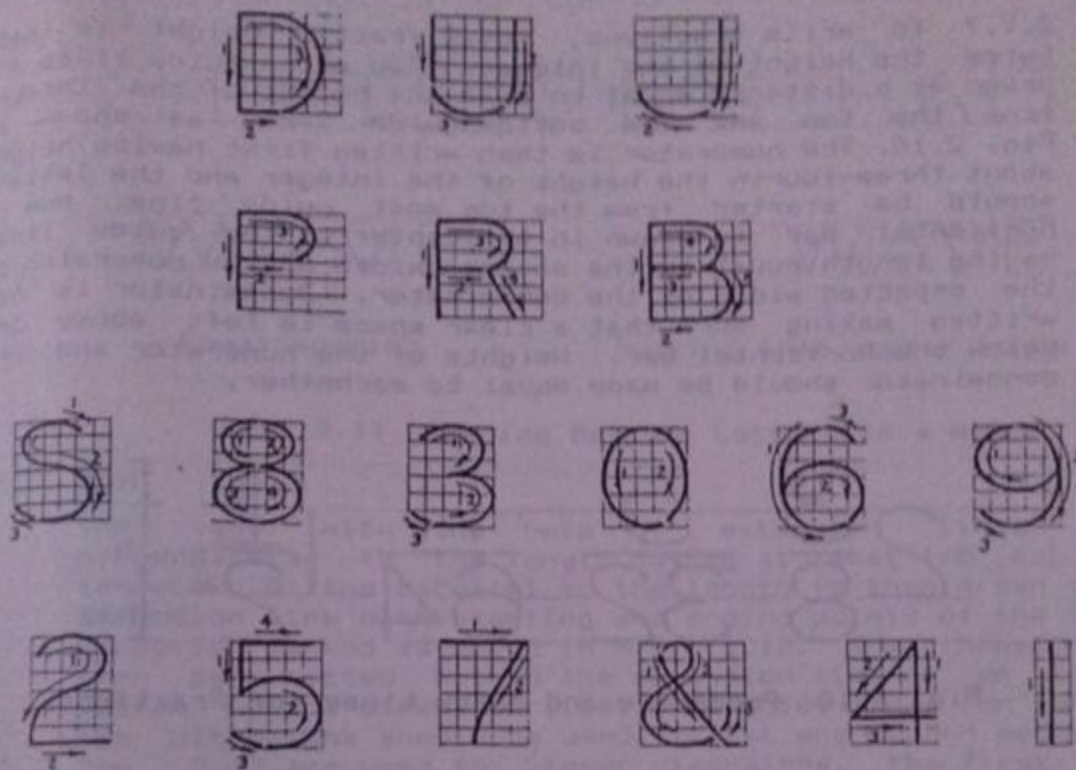

Fig. 2.9 Vertical Letters and Numerals.



2.7.5 The proportions between width and height for each letter should be as accurate as possible. The height for each letter is 6 divisions in Fig. 2.9 and the letter may be assumed to be enlarged or reduced so that its height becomes equal to the spacing of the guide lines. The width of some letters are $5/6$ th of the height (five spaces wide), others occupy a square (six spaces wide), letter 'W' is eight spaces wide and letter 'I' has width just equal to the thickness of the line.

2.7.6 In case of I-H-T-L-E-F group, all the strokes should be as vertical and as horizontal as possible. For N to W group, inclined strokes are also used while in O-D-C-G group, circular strokes are used. For all other letters, irregular curves are to be used which require much more

practice because the proportion of width and height is to be maintained at the same time while drawing the line in a single stroke.

2.7.7 To write fractions, total fraction height is made twice the height of the integer. Two extra guide lines are drawn at a distance equal to half the height of the integer from the top and the bottom guide lines as shown in Fig. 2.10. The numerator is then written first having height about three-fourth the height of the integer and the letter should be started from the top most guide line. Now a horizontal bar is drawn in the center of the guide lines having length equal to the maximum width of the numerator or the expected width of the denominator. Denominator is now written making sure that a clear space is left above and below the horizontal bar. Heights of the numerator and the denominator should be made equal to each other.

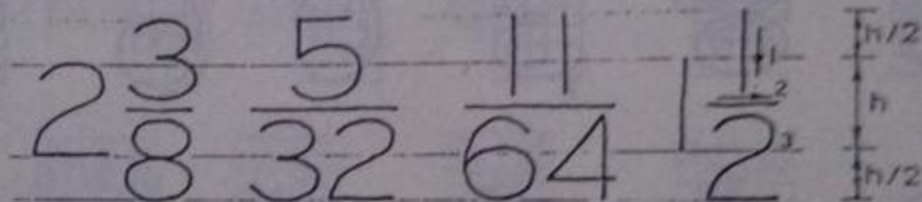

Fig. 2.10 Procedure and Guide Lines for Fractions.

Proper spacing of the letters to form words and of the words to form sentences is more important than the shape of the letters themselves for the appearance of a block of lettering. Actual spacing between the letters is not made constant in a word, instead the letters are so arranged that approximately equal areas are left between them producing a spacing which is visually uniform. Spacing between two words should approximately be equal to 3 to 4 times the average spacing between the letters in a word.

2.7.9 To write a line of letters in a given space, height of letters is so selected by experience that all the letters are properly accommodated maintaining the width/height ratio for the individual letters.

2.8 METHODS OF DIMENSIONING

No dimension should be written inside a view. The length to be dimensioned should be extended on any side of

LETTERING HALT

LETTERING HALT

WAVE

WAVE

Equal spacing

Spacing that appear to be equal

Fig. 2.11 Spacing Between Letters in a Word.

the view with the help of extension lines drawn perpendicular to the length having at least $1/8"$ gap from the view. A line parallel to the length is then drawn called dimension line with starting and ending points of the length properly marked as shown in Fig. 2.12. The dimension may then be written within the dimension line or on top or bottom of the dimension line. Two guide lines for writing the dimensions should be used. First and second methods in Fig. 2.12 are used for bigger dimensions, the first being

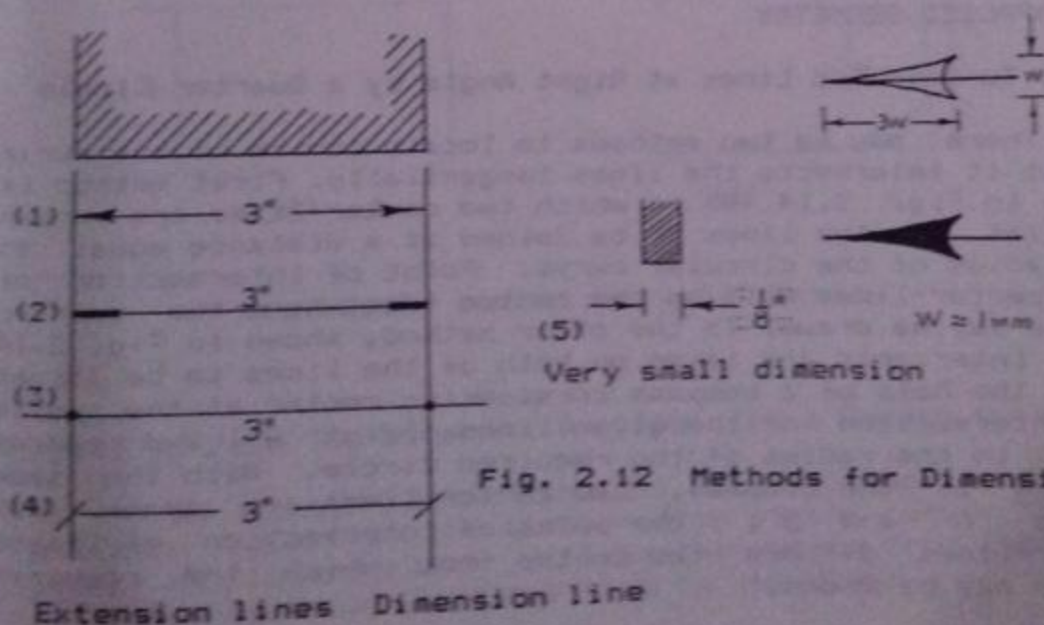

Fig. 2.12 Methods for Dimensioning.

preferable. However, for small dimensions, any of the other methods may be used. Smaller dimensions are placed nearest to the outlines of the parts to be dimensioned while larger dimensions are written outside the smaller dimensions. Numerals should be written so that they may preferably be read from the bottom or from the right-hand side of the drawing.

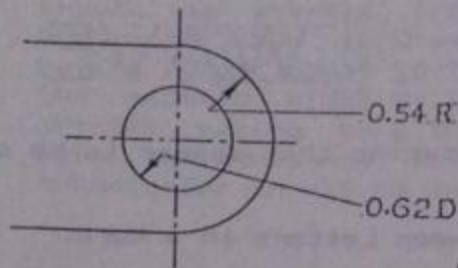

Fig. 2.13 Circular Dimensions.

For circular dimensions, draw radial dimension lines starting from the curve to be dimensioned not going upto the center. Mark long and narrow arrow at the curve and bring the tail of the line outside the view on any side where space is available and write the dimension there. If radius is mentioned, write 'R' at the end but if diameter is given, write 'D' at the end of the dimension.

2.9 APPLIED GEOMETRY

2.9.1 To Join Two Lines at Right Angle by a Quarter Circle

There may be two methods to locate centre of the curve so that it intersects the lines tangentially. First method is shown in Fig. 2.14 (B) in which two center-lines are drawn parallel to the lines to be joined at a distance equal to the radius of the circular curve. Point of intersection of the center-lines will be the centre from where the quarter circle may be drawn. In the other method, shown in Fig. 2.14 (C), intercepts are taken on both of the lines to be joined with the help of a compass considering center at the point of intersection of the given lines (point 'O') and radius equal to the radius of the required circle. With the same opening of the compass, two center-lines are drawn from points 'A' and 'B', the point of intersection of these center-lines defines the centre from which the required circle may be drawn.

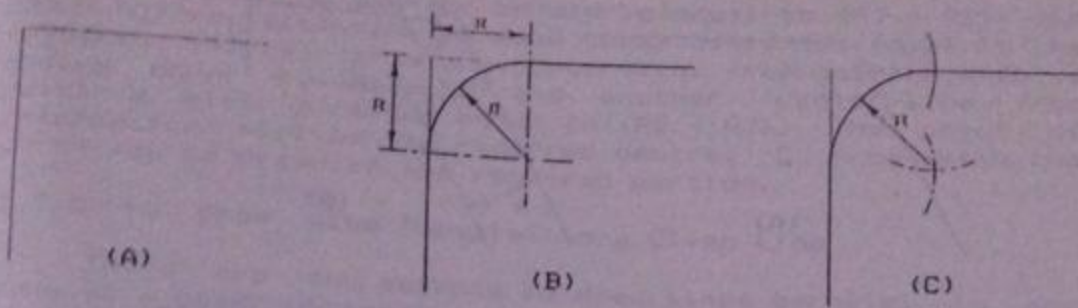

Fig. 2.14 Center for Quarter Circle.

2.9.2 To Join Two Parallel Lines by a Half Circle

To join two parallel lines 'x' distance apart by a half circle, the diameter of the circle should be 'x' making the radius equal to 'x/2'. Draw one center-line exactly in the middle of the two lines and another at a distance 'x/2' from that point where the circle must end. Point of intersection of the two center-lines will be the centre from which the half circle may be drawn with a radius equal to 'x/2'.

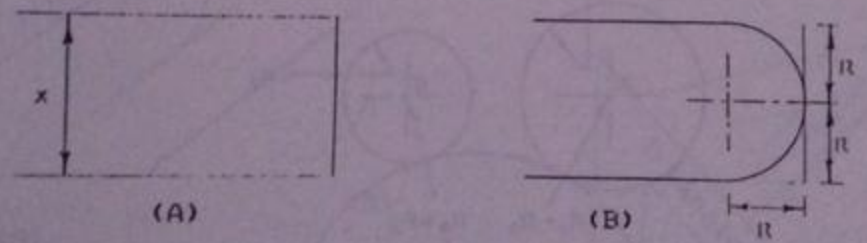

Fig. 2.15 Center for Half Circle.

2.9.3 To Join Two Lines at Any Angle by a Smooth Curve

Draw center-lines parallel to both the lines at a distance equal to the given radius of the curve 'R', the point of intersection will be the centre from which the curve may be drawn from one line to the other.

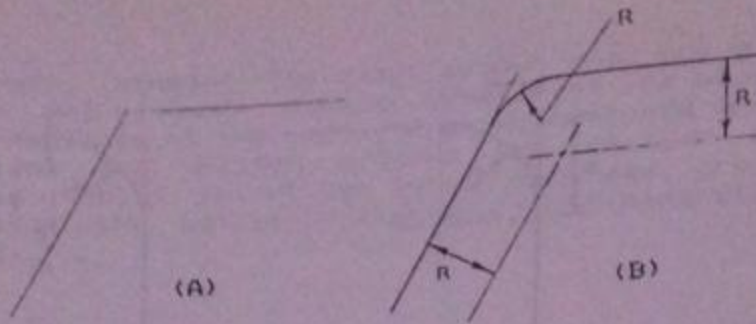

Fig. 2.16 Center for a Circular Curve Joining Two Straight Lines.

2.9.4 To Join Two Circles by a Smooth Curve

Suppose the two circles to be joined are of radii R_1 and R_2 with their centers already located on the sheet denoted by the points A and B. These two circles are to be joined tangentially by a third circle or curve of radius R_3 whose center, C, is to be properly located. If two circles intersect tangentially, then, the point of intersection and the two centers should be in a single straight line meaning

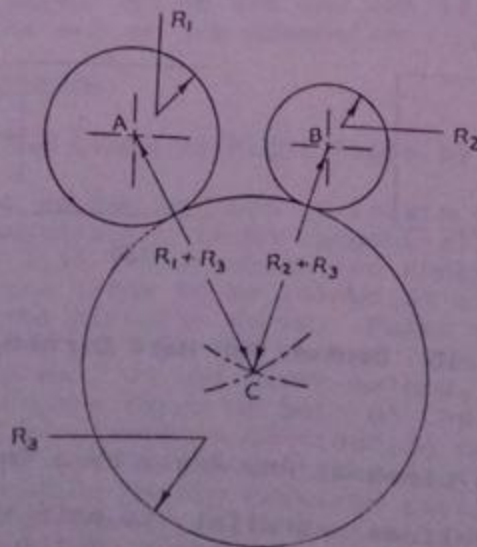

Fig. 2.17 Center for a Circular Curve Joining Two Circles.

that distance AC and BC should be equal to $(R_1 + R_2)$ and $(R_2 + R_3)$ respectively. To make these distances equal to the required values, draw one center-line from point A with a radius equal to $(R_1 + R_3)$ and another center-line from point B with a radius equal to $(R_2 + R_3)$. The point of intersection will be the required centre, C, from which the curve may be drawn in the required portion.

2.9.5 To Draw Line Parallel to a Given Line

There are two methods to draw lines parallel to any line at a given distance, first is shown in Fig. 2.18 (A) while the second is shown in Fig. 2.18 (B) to (D). In the first method, compass is opened equal to the required distance between the two lines and construction curves are drawn from any two points on the given line. Common tangent of these curves is then drawn to get the required line. In the second method, one construction curve is drawn from any point on the given line with a radius equal to the required spacing between the two lines. Triangle-1 is then oriented in such a way that one of its edges becomes parallel to the given line while triangle-2 is placed on the other side of the triangle-1 such that the latter can slide over it. Triangle-1 is then moved until its edge becomes tangent to the already drawn construction curve and the required line is drawn with it.

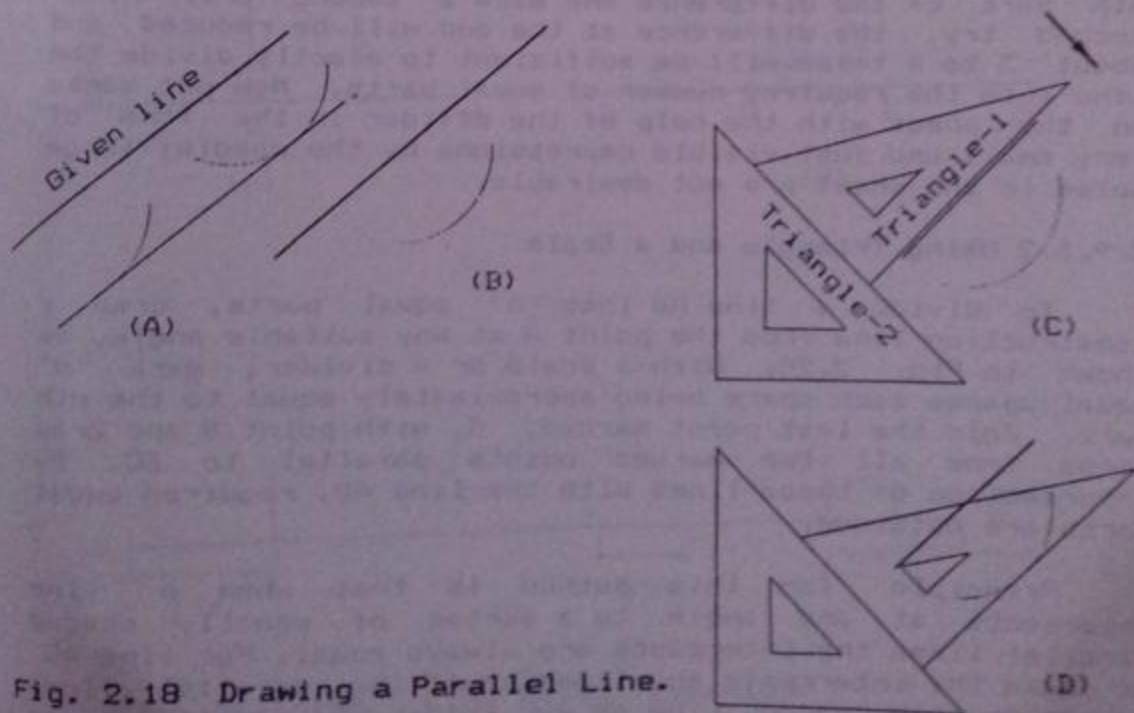

Fig. 2.18 Drawing a Parallel Line.

2.9.6 To Divide Given Length of Line into 'n' Equal Parts

2.9.6.1 Using Divider

It is a hit and trial method in which some tries are made starting from certain approximation, adjusting the difference after each try and ending when the line is exactly divided into the required number of parts. To divide a given line AB into any number of equal parts, first open the divider approximately equal to one part just by guess. Place the divider with one needle at point A and the other on the line. Swing the divider considering the second needle

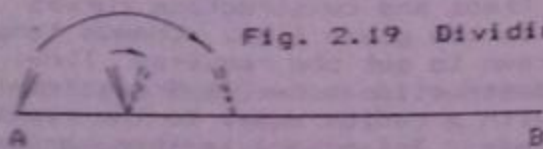

Fig. 2.19 Dividing a Line with Divider.

as pivot without making any permanent depression in the sheet. Repeat the process for the number of parts required. Some difference will be there at the end after the first try. Open or close the divider by an amount roughly equal to n th part of the difference and make a second try. After second try, the difference at the end will be reduced and about 3 to 4 tries will be sufficient to exactly divide the line into the required number of equal parts. Now put marks on the sheet with the help of the divider in the form of very small and just visible depressions by the needle; large holes in the sheet are not desirable.

2.9.6.2 Using Triangle and a Scale

To divide a line AB into 'n' equal parts, draw a construction line from the point A at any suitable angle, as shown in Fig. 2.20. With a scale or a divider, mark 'n' equal spaces each space being approximately equal to the n th part. Join the last space point marked, C, with point B and draw lines from all the marked points parallel to BC. By intersection of these lines with the line AB, required equal parts are obtained.

Principle for this method is that when a line intersects at any angle to a series of equally spaced parallel lines the intercepts are always equal. For line AC, we make the intercepts equal and hence the parallel lines become equally spaced. Line AB now intersects equally spaced

parallel lines and the intercepts must become equal to each other.

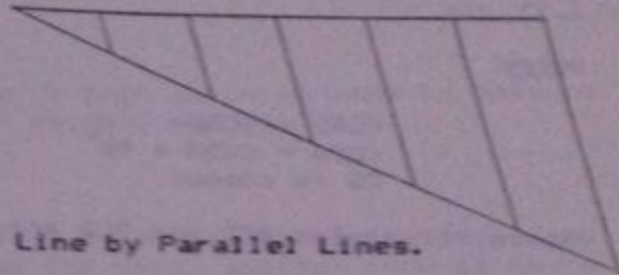

Fig. 2.20 Dividing a Line by Parallel Lines.

2.9.6.3 Using Angles Available on the Triangles

Basically there are two different methods by which we can divide a given length of line into 2 or 3 equal parts and by using a combination of these two methods, we can divide the line into 4, 6, 8, 9, 12 and 16, etc., parts.

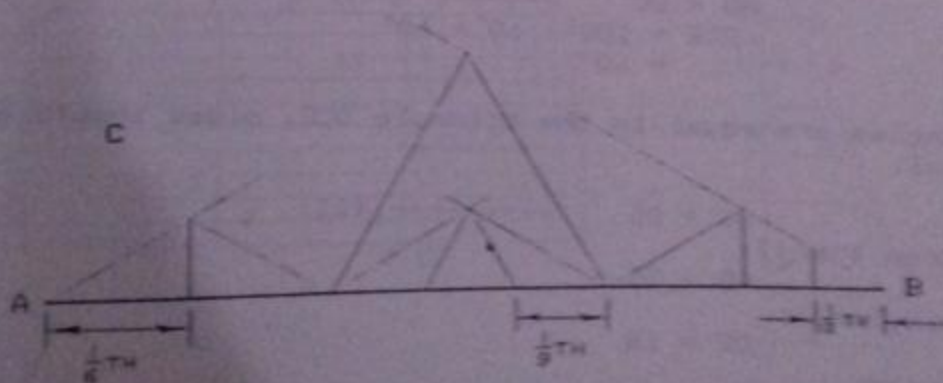
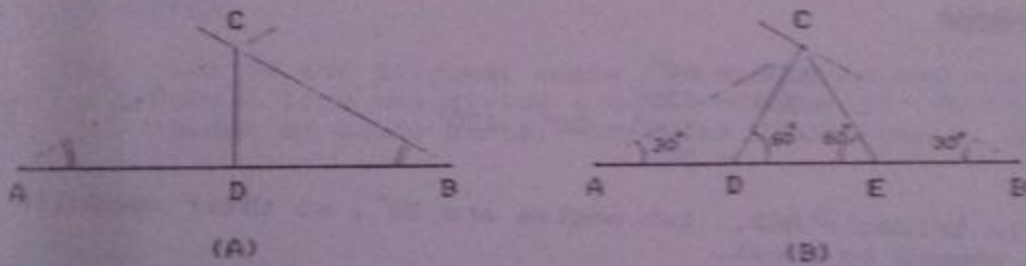

Fig. 2.21 Dividing a Line Using Triangles.

In first method, construction lines are drawn from the points A and B of the given line AB at equal angles. From the point of intersection, C, vertical construction line is then dropped to divide the line AB into two equal parts, see Fig. 2.21 (A).

PROOF

$$\begin{aligned} \angle CAD &= \angle CBD \\ \angle CDA &= \angle CDB = 90^\circ \\ CD &\text{ is common} \end{aligned}$$

Hence, triangles ACD and BCD are equal in measurements.

$$AD = BD$$

In the second method, construction lines are drawn from the points A and B of the given line AB at 30° angle, see Fig. 2.21 (B). Two construction lines are now drawn with the help of the $30^\circ - 60^\circ$ triangle making an angle of 60° with the line AB on both sides passing through the point C. Points D and E are obtained dividing the line AB into three equal parts.

PROOF

$$\begin{aligned} \angle CDE &= 60^\circ \\ \angle CDA &= 120^\circ \\ \angle ACD &= 180^\circ - 30^\circ - 120^\circ \\ &= 30^\circ \end{aligned}$$

In triangle ACD, two angles are 30° , so their opposite sides should be equal.

$$\begin{aligned} AD &= DC \quad \text{----- (I)} \\ \angle DCE &= 180^\circ - 60^\circ - 60^\circ \\ &= 60^\circ \end{aligned}$$

Angles are equal in the triangle DCE, sides should also be equal.

$$DC = DE \quad \text{----- (II)}$$

From I & II:

$$AD = DE$$

Similarly:

$$DE = EB$$

Hence:

$$AD = DE = EB = \frac{1}{3} \times AB$$

Combination of these two methods is shown in

FIG. 2.21 (C).

2.9.7 Principle and Use of Decimal Diagonal Scale in Inch-Units

PURPOSE

Decimal diagonal scale in inch units is used to measure inch-dimensions upto second decimal places.

CONSTRUCTION

Diagonal scale consists of a top line graduated into inches. On the right side of the zero, another inch is there divided into 10 equal parts each being 0.1-in long, see Fig. 2.22 (A). There is a vertical line passing through the zero-mark divided into 10 equal parts; horizontal lines are drawn from all of these points. On the lowermost or the 10th horizontal line, the inch on the right side is again divided into 10 equal parts. Points on the top line to the right of the zero are joined diagonally with the points on the lower line such that each point on the top line is joined with the one space ahead point on the lower line.

PRINCIPLE

The name of the diagonal scale is taken from the fact that a diagonal line may divide a small dimension further into any number of equal parts. Consider the triangle ABC

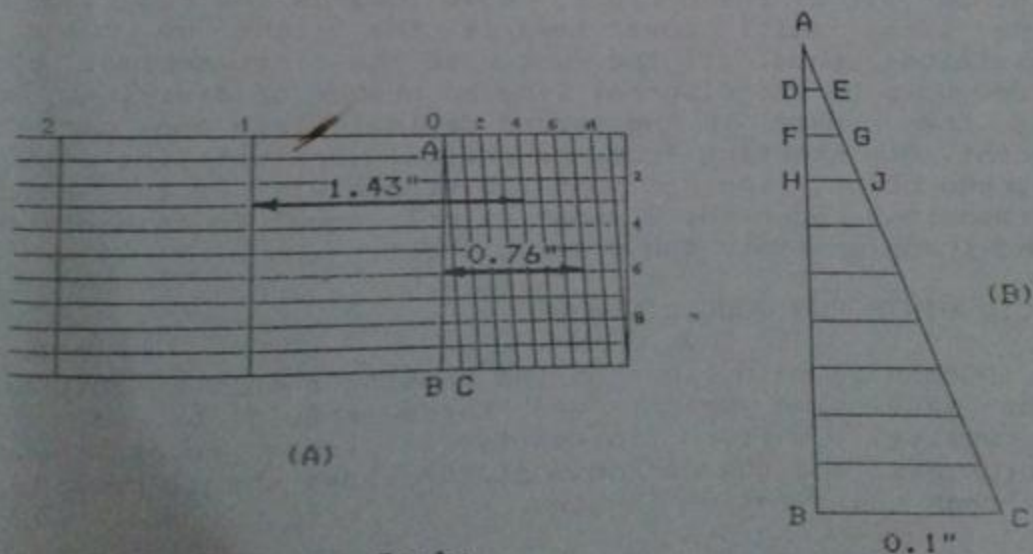

Fig. 2.22 Diagonal Scale.

marked in Fig. 2.22 (A) and shown on enlarged scale in Fig. 2.22 (B). BC is a dimension equal to 0.1" which is to be further divided into 10 equal parts, AC being the diagonal line.

$$\begin{aligned} \angle ADE &= \angle ABC = 90^\circ \\ \angle DAE &= \angle BAC \quad (\text{common}) \end{aligned}$$

The triangles DAE and BAC are similar and hence the ratio of their corresponding sides must also be equal.

$$\begin{aligned} \frac{DE}{BC} &= \frac{AD}{AB} \\ &= \frac{1 \text{ div.}}{10 \text{ div.}} \\ &= \frac{1}{10} \\ DE &= \frac{1}{10} \times BC \end{aligned}$$

Similarly:

$$\begin{aligned} FG &= \frac{2}{10} \times BC \\ HJ &= \frac{3}{10} \times BC \quad \text{and so on} \end{aligned}$$

If BC = 0.1", then DE = 0.01", FG = 0.02", HJ = 0.03" and so on

METHOD TO USE

To measure any dimension upto second decimal place, start from vertical line corresponding to the whole number inches left of the decimal, move towards the right, go upto the zero, still move towards the right by number of divisions equal to the number in the first decimal place, come down on the diagonal line by number of divisions equal to the number in the second decimal place and mark that point. Now starting from the initial vertical line upto this marked point, the horizontal distance will be the required dimension. Open the divider exactly equal to this dimension and transfer it to the drawing sheet.

2.10 HINTS FOR GOOD LINEWORK

1. Ordinary main lines on the drawing should be thin but at the same time bright and these should be of uniform intensity. Uniform intensity of lines means that the thickness and the darkness of the lines should remain same through their entire lengths.
2. All the measurements should be exact upto a very high

degree of accuracy. Difference in measurement, in any case, should not be more than $1/64$ " (0.3 mm) per one line of length upto 12".

3. No marks or points should be visible on the finished drawing. To lay out the dimensions during drawing work, either use a very small point from needle of the divider or a very small and light transverse construction line.

4. All horizontal and vertical lines should be truly horizontal and vertical.

5. Use proper shape of the line to be used in a particular situation according to the fixed conventions.

6. Intersection of the lines should be perfect which means that starting and ending points of the lines should be well-defined; line should not be projecting from the intersection and there should be no gap inbetween the lines.

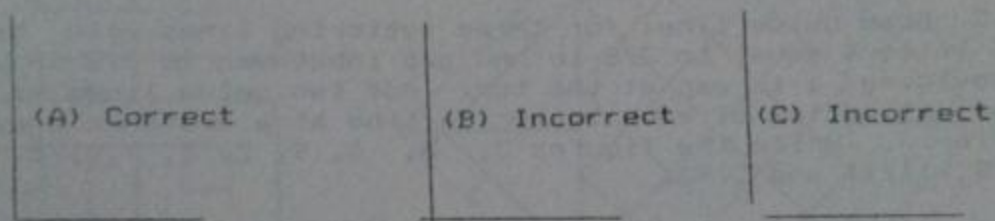

Fig. 2.23 Corner Formed by Lines.

7. The circular lines drawn with compass should have the same thickness and brightness as that of the other lines. For that, lead in the compass may be kept one grade softer than lead in the pencil. For drawing circles, compass is always opened equal to the radius; if diameter of a curve is given, first divide it by 2 to find the radius.

8. A slight rotation of the pencil while drawing the line keeps the conical-shaped pencil in good condition and lines of uniform thickness may be obtained. However, when thickness of the lines starts increasing, the pencil should be sharpened again.

PROBLEMS

2.1 Leaving a gap of 1-in from the top border line, draw guide lines for five lettering lines maintaining height of letters equal to $\frac{3}{8}$ -in and gap inbetween two lettering lines equal to $\frac{1}{2}$ -in. Write each of the letters I, H, T, L, E, F, N, Z, Y, V, A, M, W, and X, four times in pencil strictly according to the standard procedure. For the first line, gap inbetween similar letters may be kept roughly equal to $\frac{1}{16}$ -in, while, gap between two different letters may be kept roughly equal to $\frac{1}{4}$ -in. From the second line, adjust the spacing properly so that no space is left on the sides and also no letter is to be omitted. Write problem numbers in the top 1-in spaces provided for the purpose after completing first three problems.

2.2 Leave a gap after the first problem for writing the problem number and repeat the procedure of Prob. 2.1 for the letters O, Q, C, G, D, U, J, B, P, R, S, and &.

2.3 Draw guide lines for three lettering lines with height of letters equal to $\frac{3}{8}$ -in and gap inbetween as $\frac{7}{8}$ -in after providing 1-in gap at the top. Add two guide lines at top and at bottom of each lettering line at a distance equal to $\frac{3}{16}$ -in. Write the figures 3, 8, 6, 9, 2, 5, 7, $\frac{1}{2}$, $\frac{3}{4}$, $\frac{5}{8}$, $\frac{11}{16}$ and 2.98.

2.4 Letter the following specification using height of letter as $\frac{1}{4}$ " and gap inbetween lettering lines as $\frac{3}{8}$ ".

$1\frac{1}{2}$ " THICK BRICK TILES LAID IN (1:3) C/S MORTAR OVER
1" THICK PROPERLY SLOPPED MUD PLASTER OVER
3" THICK EARTH INSULATION OVER
80 GMS./SQ.M. POLYTHENE SHEET OVER
2 COATS OF HOT BITUMEN OVER
R.C.C. STRUCTURAL SLAB

2.5 Same as Prob. 2.4 for the following specification.

$1\frac{1}{2}$ " THICK FLOOR FINISH OF (1:2:4) P.C.C. OVER
4" THICK (1:4:8) P.C.C. OVER
4" SAND FILLING OVER
WELL COMPACTED EARTH

2.6 Design a title for your department/college and draw it properly.

2.7 Redraw the figure provided. Divide the sheet symmetrically for the assigned problems and find center of

space for the first problem. Draw horizontal and vertical construction lines from the center of space, measure $2\frac{1}{2}$ -in on all the four sides, draw horizontal construction lines from top and bottom marks and vertical construction lines from the left and the right marks to make a $4\frac{1}{2}$ -in square. Divide lower side into seven equal parts with the help of the divider having screw inbetween the two arms. With the same opening of the divider as in the last try, divide the left side also into seven equal parts. Draw horizontal and vertical construction lines inside the square through the marked points. Looking at the pattern shown in the figure, erase the parts not needed. Draw firm lines in the required portions showing good linework.

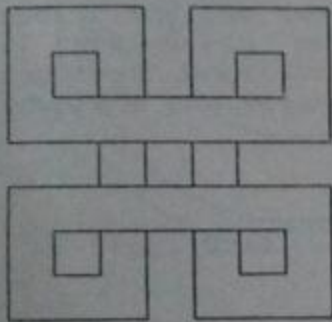

Prob. 2.7

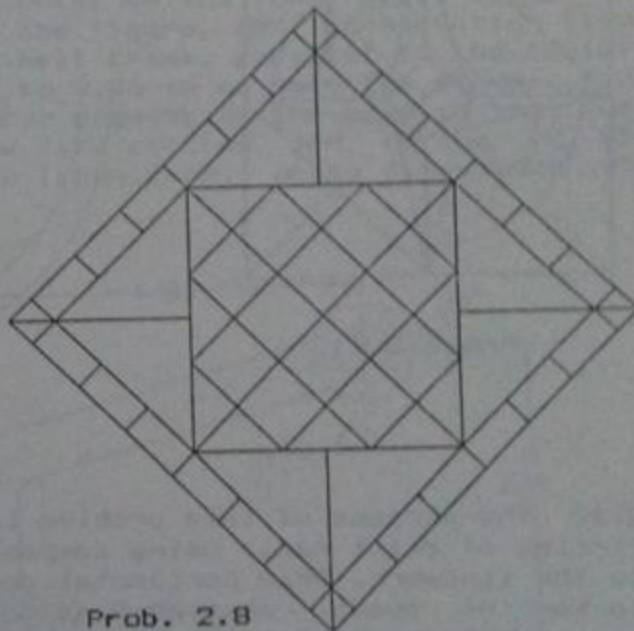

Prob. 2.8

2.8 Draw two intersecting 45° diagonals in the form of construction lines through the center of space. Measure 36mm on any diagonal starting from the center and draw horizontal and vertical construction lines from the marked point. From the points obtained on the other diagonals, draw horizontal and vertical lines to form a square. With the scale, lay off 12mm spaces along these diagonals and draw 45° lines from all the marked points. Add a 72mm square and a border 6mm wide as shown. Remove extra lines and complete the pattern by projecting the corners of the inner 12mm squares.

2.9 Draw construction lines for the 45° diagonals and vertical and horizontal center-lines of a 4-in square with its center located exactly at the center of the space available for the problem. Draw a $7/8$ -in diameter construction circle and remove diagonals outside this circle nearly upto the corners. Complete the star-shape as shown in the figure using firm lines. Draw a $2\frac{1}{2}$ -in and a $3\frac{1}{2}$ -in circle using firm lines only in the required portions. Make the required construction lines firm and complete the design.

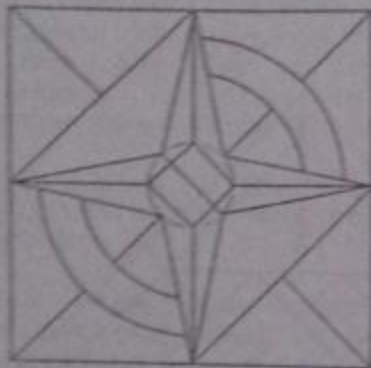

Prob. 2.9

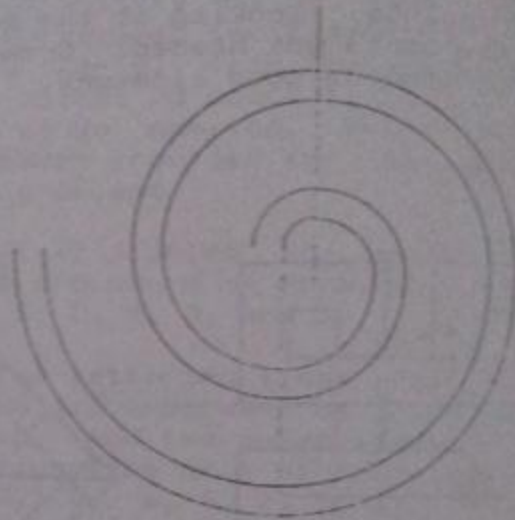

Prob. 2.10

2.10 The purpose of this problem is to practice for drawing circles of exact radii using compass with due consideration to the linework. Draw horizontal and vertical lines from the center of space, measure 3-mm on all the sides and draw as shown in the figure. Check whether the central square is exactly 6-mm square or not. From top right corner as center, draw two arcs with radii 6-mm and (2×6) -mm in the top left quadrant. Shift the center to the lower right corner and draw curves of radii (2×6) -mm and (3×6) -mm in the top right quadrant. In the same way, move the compass around the square in a clockwise direction drawing two arcs from each center, one of radius equal to that for the previous center and the other of radius obtained by adding 6-mm to the previous radius. Complete three turns, two of which are shown in the figure.

2.11 Find out the approximate height 'h' and length 'l' of

38

the bell crank between centers of the circular ends. Subtract the height 'h' from the height of the space 'H' available on the paper and divide the answer by 2 to obtain the height 'y' of the lowermost center from the bottom of the space. In the same way a distance 'x' equal to $(L - 1)/2$ should be left horizontally to find the same center; where, 'L' is the length of space reserved for the problem. Locate the center and draw a center-line at an angle of 45° with the horizontal using the 45° -triangle. Measure 2.74-in on this line and locate the center of the middle circle. From this point, draw a vertical construction line, cut it at a distance equal to 3.14-in, draw a horizontal construction line, measure 4.18-in on this line and locate the center for the right circular part. Draw a center-line making an angle of 15° with the horizontal on the lower left side and complete center-line for the figure. Add construction lines to indicate width of the bell crank, parallel to the center-line at a distance equal to 0.26-in on both the sides. Find center for the smooth curve present at the bend in the body of the crank and draw firm circles and curves in the required portions. Make lines firm, write dimensions and complete the figure.

Prob. 2.11

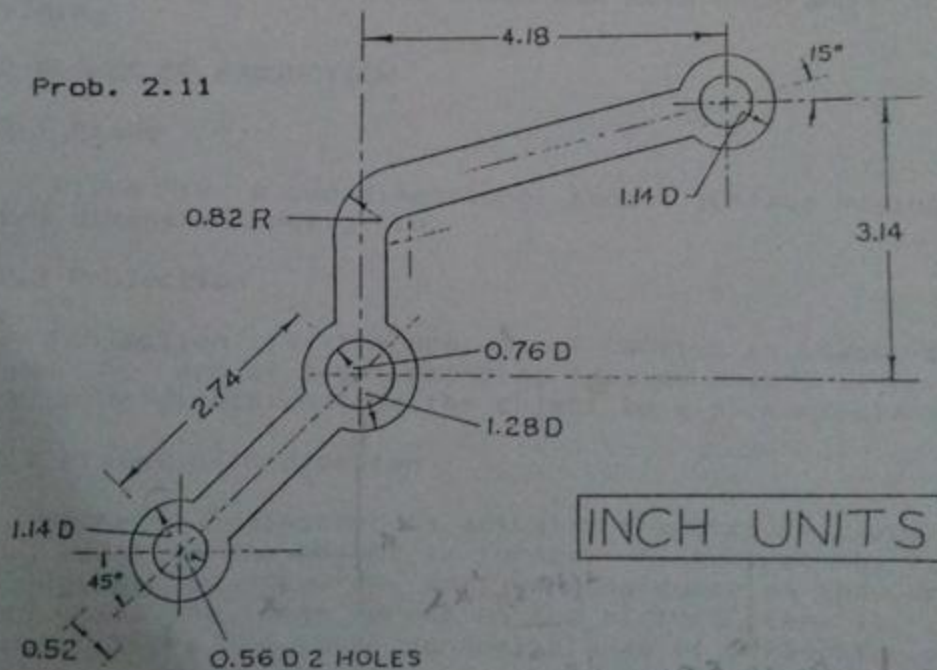

2.12 Redraw the figure provided.

METRIC

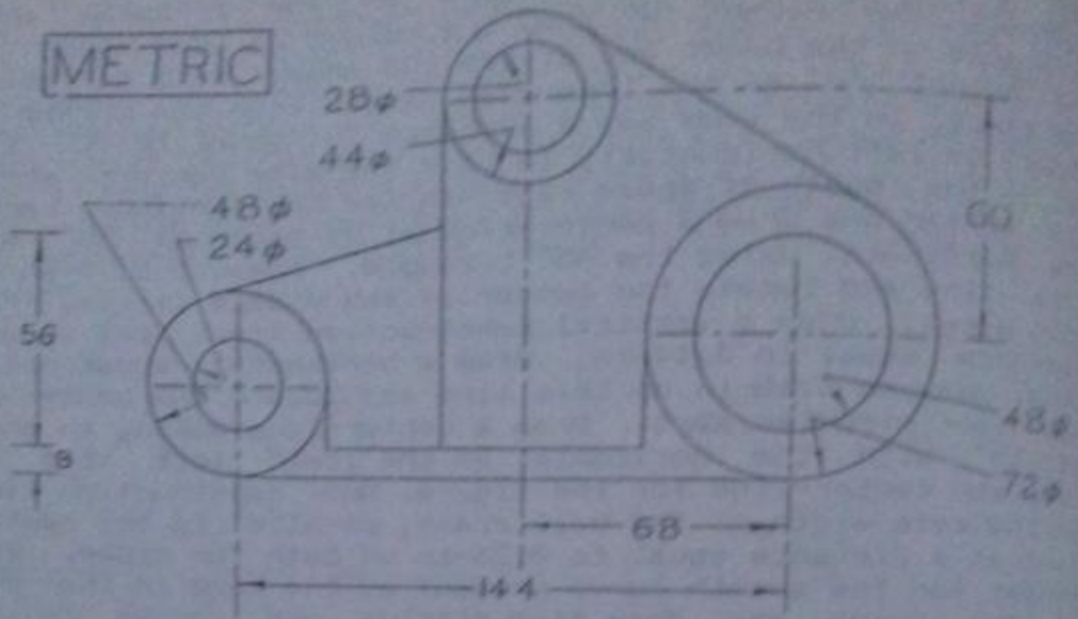

Prob. 2.12

CHAPTER NO.3

ORTHOGRAPHIC DRAWING

3.1 FACES OF THE OBJECT

There are six main faces of the object namely front, back or rear, left side, right side, top and bottom. That side of the object which contains the larger horizontal dimension is generally fixed as the front side in case of machine drawing, whereas, in building drawing, front side of the building is that side which has main entrance to the building.

3.2 PLANES OF PROJECTION

3.2.1 Plane

Plane is a two dimensional smooth surface having the third dimension negligible.

3.2.2 Projection

Projection is the process of causing an image to be formed by rays of sight emerging from an object taken in a particular direction from the object to a picture plane.

3.2.3 Planes of Projection

Plane of projection is actually the picture plane over which image of the object is formed. Picture plane, in case of engineering drawing, may be considered as the drawing paper while the image formed on the picture plane is called a view. There are three general planes of projection namely frontal, end or profile, and horizontal plane as shown in Fig. 3.8.

3.2.3.1 Frontal Plane: Any plane parallel to a vertical plane passing through main features of the object on the front is called frontal plane. This plane shows height and

length of the object. Frontal plane is always defined with reference to the object while the other two planes are later defined with reference to it without considering the object itself.

3.2.3.2 End or Profile Plane: Any vertical plane at right angle to the frontal plane is called end or profile plane which includes height and width of the object.

3.2.3.3 Horizontal Plane: As the name implies this plane is horizontal and is at right angle to both the frontal and the profile planes. This plane includes length and width of the object.

3.3 SPACE DIMENSIONS

3.3.1 Length

It is the perpendicular distance between two profile planes that contain the object. It is actually the projected horizontal dimension of the object on the front. Care must be taken for the inclined and the curved surfaces while finding out the total length.

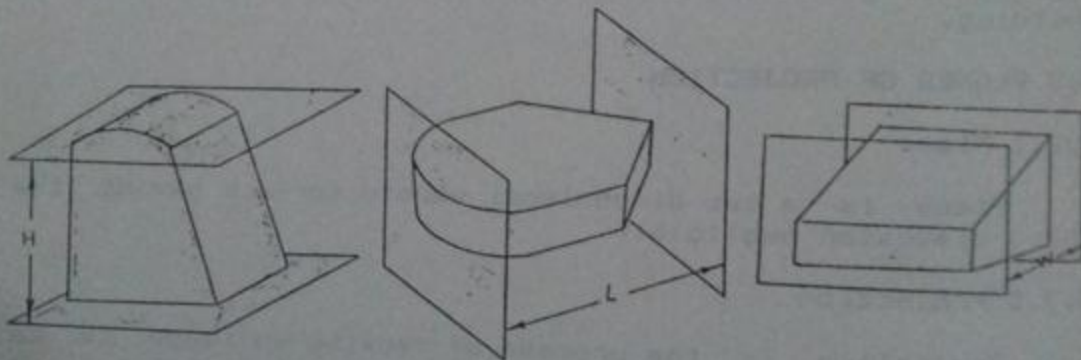

Fig. 3.1 Length, Width and Height of the Object.

3.3.2 Width

It is the perpendicular distance between two frontal planes that contain the object. Always find total dimension considering the overall object and not a part of it.

3.3.3 Height

It is the perpendicular distance between two horizontal

planes that contain the object. The dimension should always be vertical.

3.4 DIMENSIONS APPEARING IN THE VIEWS

The dimensions which appear in three dimensional photographs or drawings are generally not the actual dimensions instead these depend upon the angle of vision. An edge appears in true length when it is parallel to the plane of projection and it appears as a point when it is perpendicular to the plane. The edge appears shorter in length than actual when it is inclined to the plane of

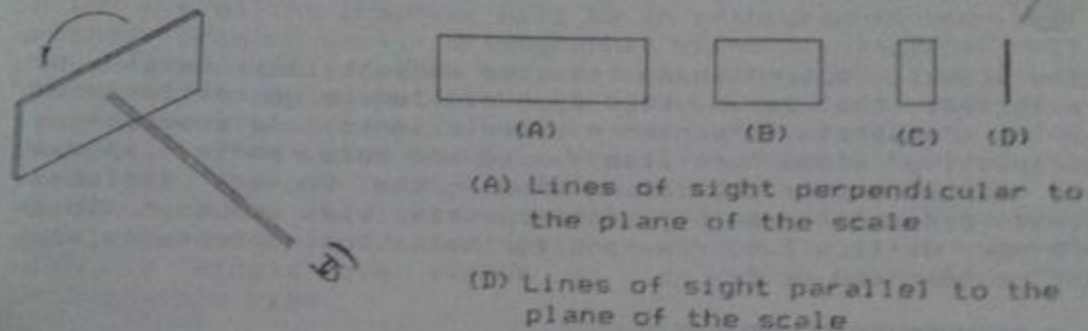

Fig. 3.2 Views of a Diagonal Scale From Different Angles.

projection. For example, if we look at a diagonal scale from different angles (to form two dimensional views because of its small thickness), its length will vary as shown in Fig. 3.2.

3.5 PERSPECTIVE PROJECTION

If the rays of sight emerging from the object tend to meet at any station point and a picture plane is introduced inbetween, the view obtained on this picture plane will be a perspective view and the method of projection will be perspective projection. Suppose the observer is standing at a finite and comparable distance from the object. Rays of sight, in this case, will emerge from all points of the object and will converge in the eye of the observer called station point. The view obtained in the eye of the observer will then be a perspective view; the same view is obtained if we introduce a transparent picture plane inbetween the observer and the object. Angle of vision for all parts of the object will be different and hence the dimensions will vary from point to point. Besides the view obtained in our eyes, camera photograph is a good example of the perspective view. Advantage of a perspective view is that the three

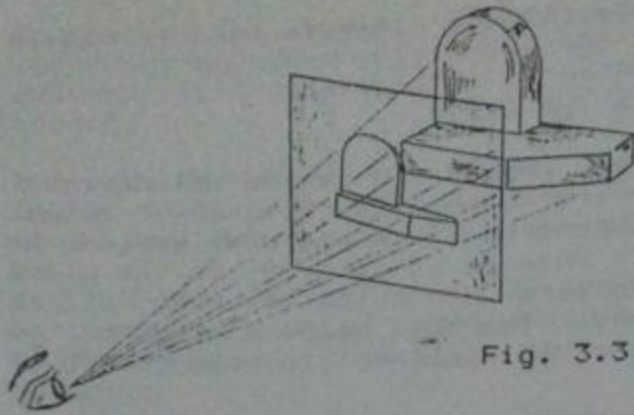

Fig. 3.3 Perspective Projection.

dimensional outer shape of the object may easily be conceived, that is why this type of view is generally used by the architects to convince their clients. In some cases, perspective views are also shaded and coloured to improve the appearance of a building showing the surface finishes also. Disadvantages of the perspective view are that they are more difficult to draw and further actual dimensions are not represented on it.

3.6 ORTHOGRAPHIC PROJECTION

Orthographic projection is the method of representing the exact shape of an object by carrying perpendicular rays from two or more sides of the object to picture planes generally at right angles to each other, collectively the views on these planes must describe the object completely. We assume in this case that parallel rays of sight emerge from the object striking the plane of projection at right

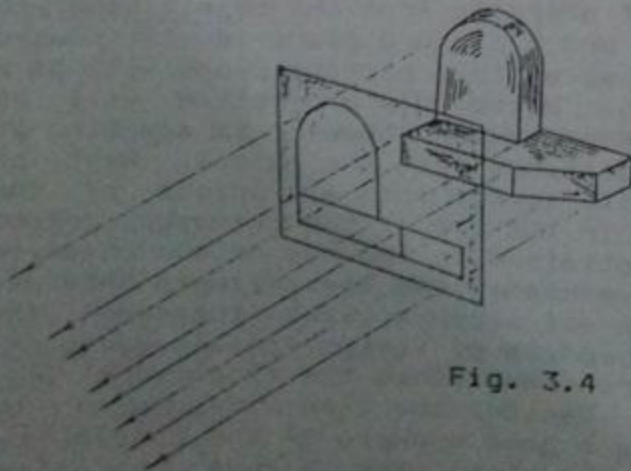

Fig. 3.4 Orthographic Projection.

angles. The word "ortho" means 90° .

As the observer of section 3.5 moves backwards from the object, the difference of angle between the rays from various points of the object starts decreasing. Consider the observer to be at a theoretically infinite distance from the object, in other words, assume that the distance inbetween the observer and the object becomes much greater than the dimensions of the object. The rays of sight will become nearly parallel to eachother and perpendicular to the picture plane. The image so formed on the picture plane or in the eye of the observer will be an orthographic view. For ordinary drawing work, orthographic views are imagined only and we are usually unable to see such views actually. It is important to note that although these views are generally imagined, orthographic views are not purely imaginary. For example, the view taken directly underneath from an aeroplane, when it is at its full altitude, is very close to an orthographic view. Also a model, having maximum dimension equal to 4-in placed at a distance of about 6-ft and viewed with a single eye yields a view very near to the orthographic view.

Important points about orthographic projection are as follows:

1. The rays of sight are always parallel to eachother and perpendicular to the plane of projection.
2. Actual dimensions of the object are represented on the views and we may scale out the dimensions from these views.
3. Orthographic views are always two dimensional, one of the three general dimensions is missing in a particular view. Hence the shape is not represented by a single view and generally three views from different directions are required.
4. Using certain fixed conventions, we may also communicate the inner shape of the object on these views.
5. As a general rule, no shading or colouring is done in orthographic views except in some special cases.

3.7 LINES TO FORM A VIEW

Orthographic views are drawn by using various types of lines and generally no shading is used, hence, we must have a clear-cut idea about where a line is to be drawn. The lines on a drawing may indicate three types of directional

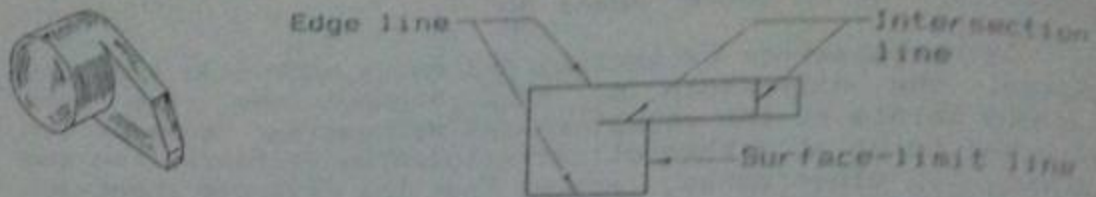

Fig. 3.5 Lines to Form a View.

change in the body of the object as shown in Fig. 3.5 and listed below.

3.7.1 Intersection Line

An intersection line is a line formed by the meeting of two surfaces when either one is parallel and one at an angle or both are at an angle to the plane of projection.

3.7.2 Surface Limit Line

A surface limit line indicates the reversal of direction of a curved surface. Suppose a curved part is to be shown in a particular view, the curvature starts from one end and goes towards the left side of the view. After covering a certain distance towards the left, it starts moving towards the right. That extremity of the curve for a particular view at which the change of direction takes place is indicated by a surface limit line.

3.7.3 Edge Line

An edge line is a type of intersection line showing the edge of a receding surface that is perpendicular to the plane of projection.

3.8 THREE ORTHOGRAPHIC VIEWS

Most commonly only three orthographic views are drawn for an object namely front view, top view and end view. End view should be drawn from that side which contains greater and important features, that is, in some cases, left end view is drawn while in others right end view is preferred. A perspective view is equivalent to an equation involving x , y and z coordinates to describe a shape. This type of equation is solved by putting one of the variables equal to zero each time and getting three two-dimensional equations which may be considered equivalent to the three orthographic views.

3.8.1 Front View

The orthographic view from the front side of the object obtained on any frontal picture plane is called a front view. Front view may also be defined as the graphical plotting of height against length of the object for all the intersections and surface limits whether visible or hidden, from the front. Width of any part can never be indicated on this view.

3.8.2 Top View

The orthographic view from top of the object obtained on any horizontal plane of projection is called a top view. It is actually graphical plotting of width against length of the object for all the intersections and surface limits whether visible or hidden from the top. Height dimension is always missing in this view and the parts at various heights will appear at the same level without any difference.

3.8.3 End View

The orthographic view from any side of the object on a profile plane of projection is called end view or side view. With reference to the front side, end view may be the left end view or the right end view. Mathematically, this view may be considered as graphical plotting of height against width of the object for all the intersections and surface limits whether visible or hidden from that side. Length dimension can never be indicated in an end view.

3.9 CLASSIFICATION OF SURFACES

Horizontal, frontal and profile surfaces are those which are parallel to the horizontal, frontal and profile planes of projection and these will be represented by their actual size in the respective views but are shown just by lines in the other views. Auxiliary or inclined surface is inclined to two of the planes of projection but is perpendicular to the third. The inclined surface will appear as an inclined edge in the view for which it is parallel to the plane of projection, while, in the other views, it will be shown by reduced dimensions. A surface inclined to all the three planes of projection is termed oblique or skew surface and is shown by reduced dimensions and inclined lines in all the views.

Curves perpendicular to the picture planes will be shown by rectangles because actually the curves move out of the paper or into the paper. Sometimes very light lines at

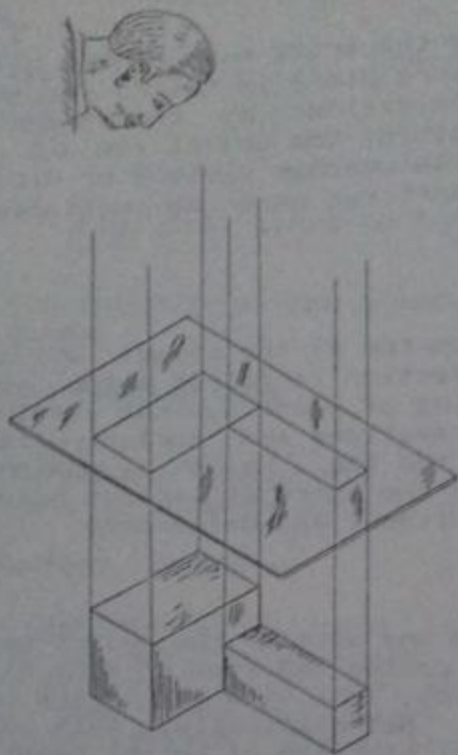

A - Horizontal surfaces

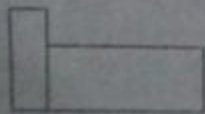
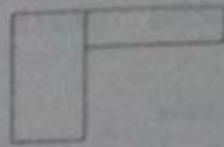

B - Frontal surfaces

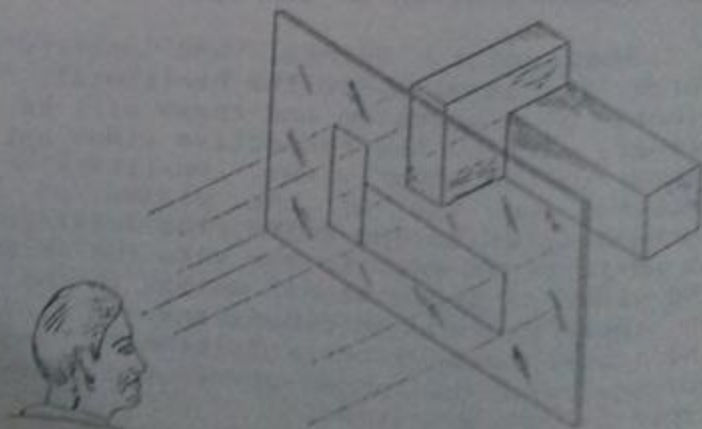
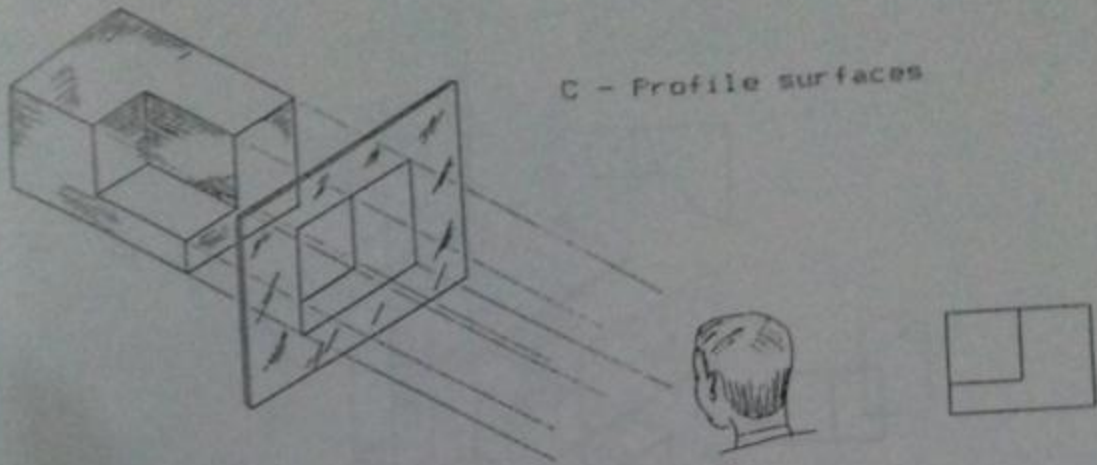

Fig. 3.6 Types of Surfaces.

Fig. 3.6 Contd.



D - Inclined surface

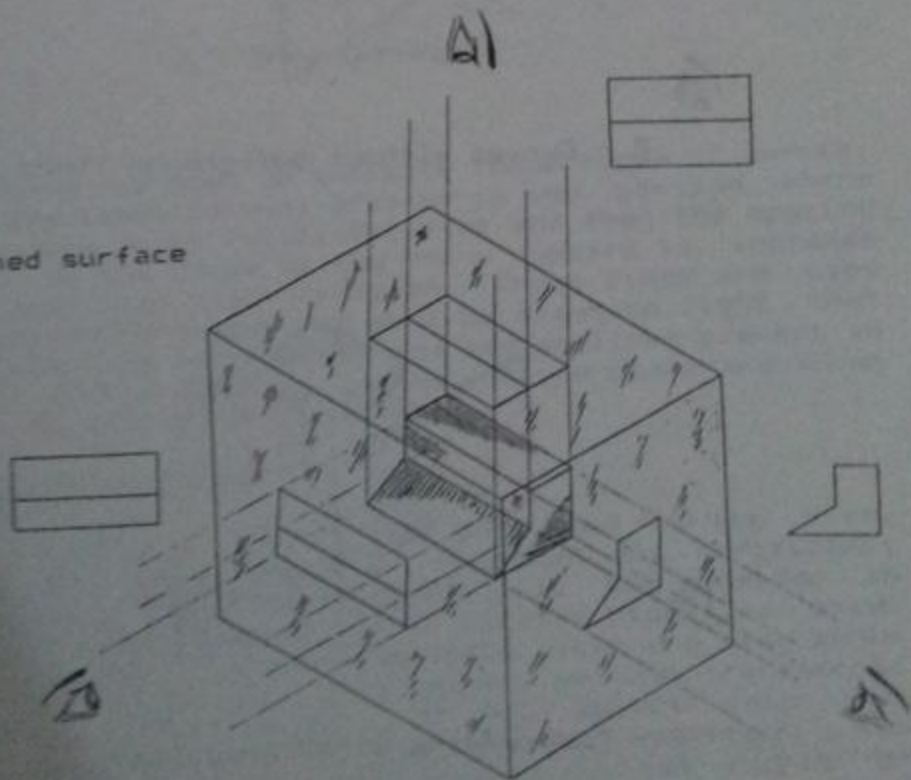
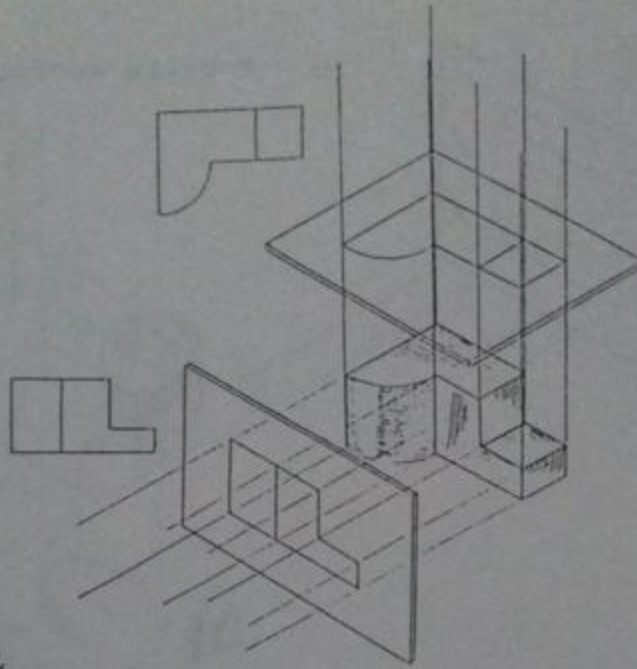

Fig. 3.6 Contd.

A)



B)

E - Curves without background lines

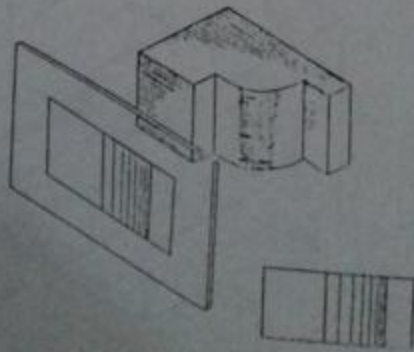

B)

F - Curves with background lines

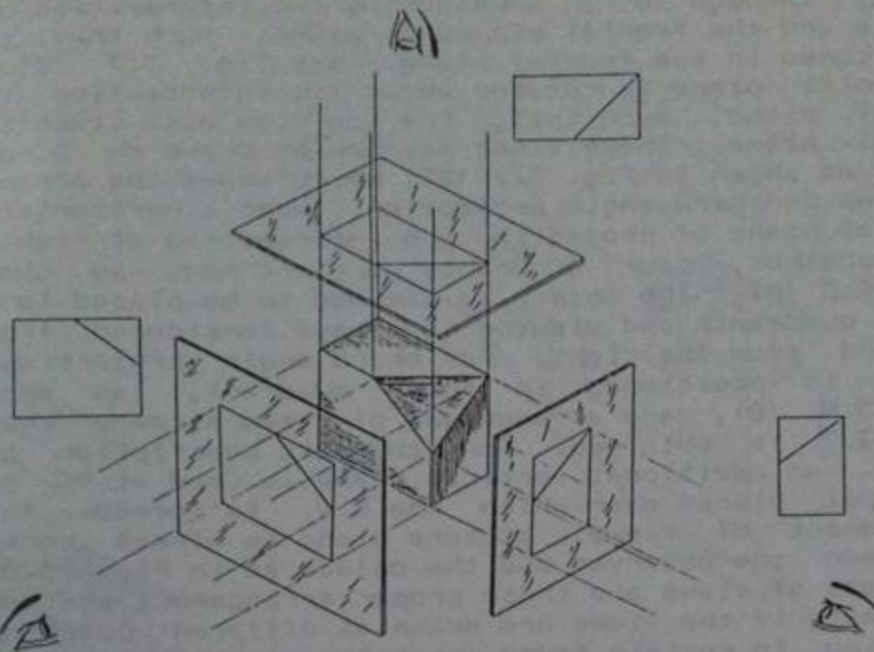

G - Skew surface

varying spacing are used to indicate these types of curves. Spacing of the lines is made greater in the portion where the curve appears to be relatively flat and then the spacing is decreased as the slope of the curve appears to increase from that particular view-direction. These lines are used only as a background symbol and must be drawn so light that they do not interfere with dashed and center-lines present in that portion. Curves parallel to the picture plane are shown by lines having the actual curvature.

3.10 ARRANGEMENT OF VIEWS

Upto this stage, it has been discussed how top view, front view and end view can be obtained on horizontal, frontal and profile planes respectively. Now consider an object to be placed inside a box of picture planes as shown in Fig. 3.7 (A). The three orthographic views are also shown on the respective planes, that means; we have transformed the three dimensional shape of the object into two dimensional views. Still these views, although two dimensional, are lying in three dimensions and cannot be

shown on a drawing paper. For that the profile plane is rotated through 90° , considering the intersection of the profile and the frontal planes as pivot, such that, the end view comes in the frontal plane, see Fig. 3.7 (C). Also horizontal plane is rotated about its intersection with the frontal plane, such that, the top view also comes in the frontal plane. These views may now be drawn on a drawing paper, as shown in Fig. 3.7 (D), which shows the arrangement of views in third angle projection. When a horizontal and a vertical plane of projection are intersecting at right angle to each other, four quadrants are formed, as shown in Fig. 3.8 (A). The object is assumed to be placed in any of these quadrants and viewing is always considered from the top and from the right. For third angle projection, the object is positioned in third quadrant, as shown in Fig. 3.8 (B), and arrangement of views already shown in Fig. 3.7 is obtained. For complete description of the object, an additional vertical plane is used at 90° to the principal planes over which the E.V. is formed. In this arrangement of views, picture plane is always considered inbetween the observer and the object as in Fig. 3.8 (B). Exactness of views and their proper arrangement are equally important, if the views are drawn at different positions not according to certain fixed conventions, the shape will be wrongly communicated because the reader will imagine the views to be rotated to their original position to conceive the shape of the object. It is important to note that actually, for the object, bottom line of the top view and top line of the front view coincide and top view is actually going inside the drawing paper according to the width dimension. Similarly, end view should also be considered as going inside the drawing paper.

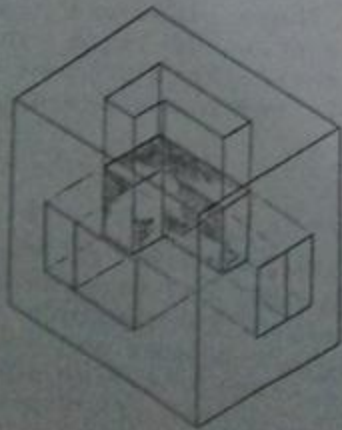

A - Object within a glass box

Fig. 3.7 Arrangement of Views in 3rd Angle Projection.

Fig. 3.7 Contd.

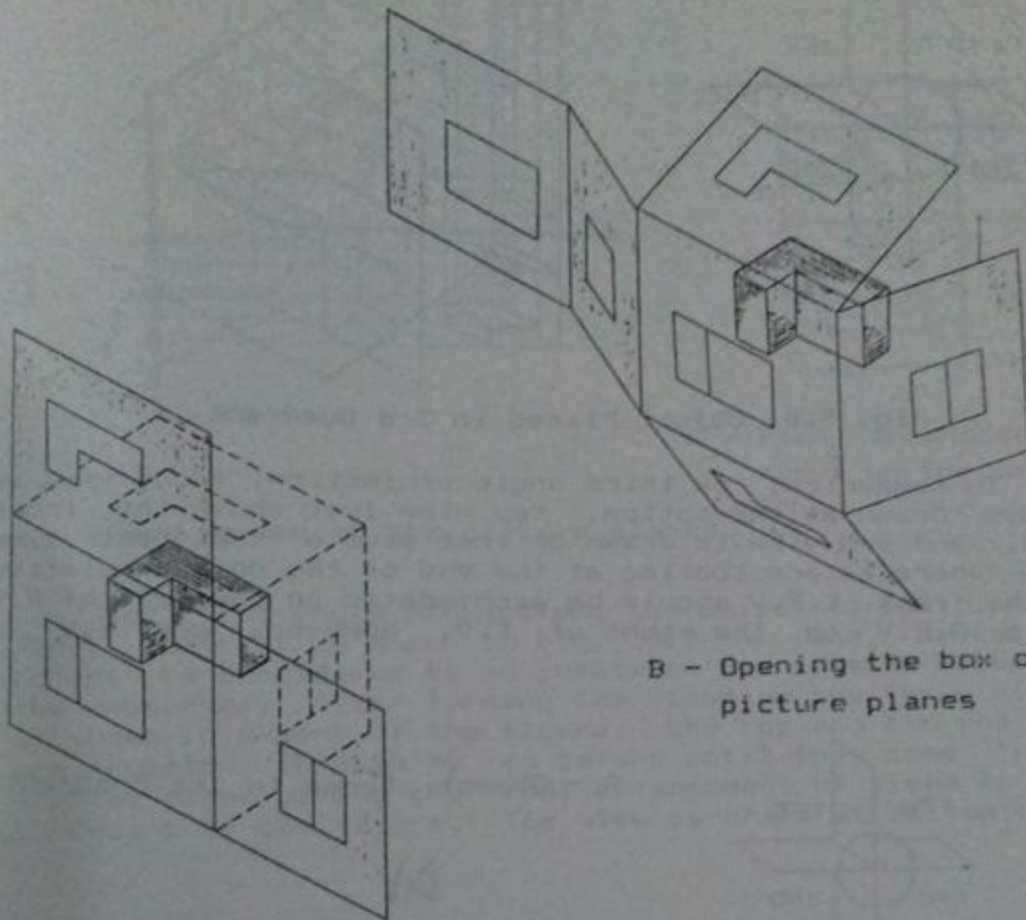

B - Opening the box of picture planes

C - Picture planes after opening of the box

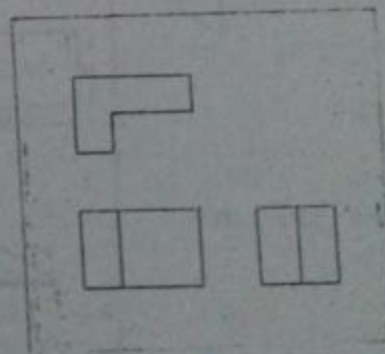
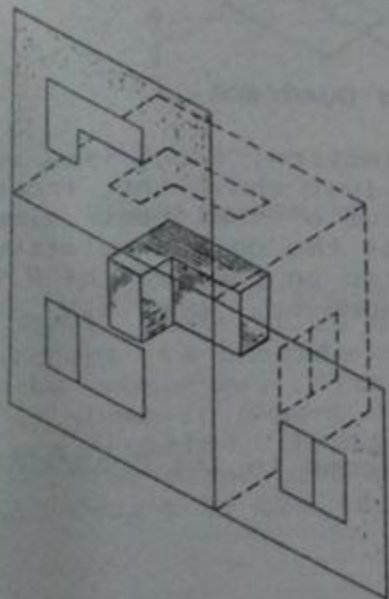

D - Final arrangement of views on the drawing

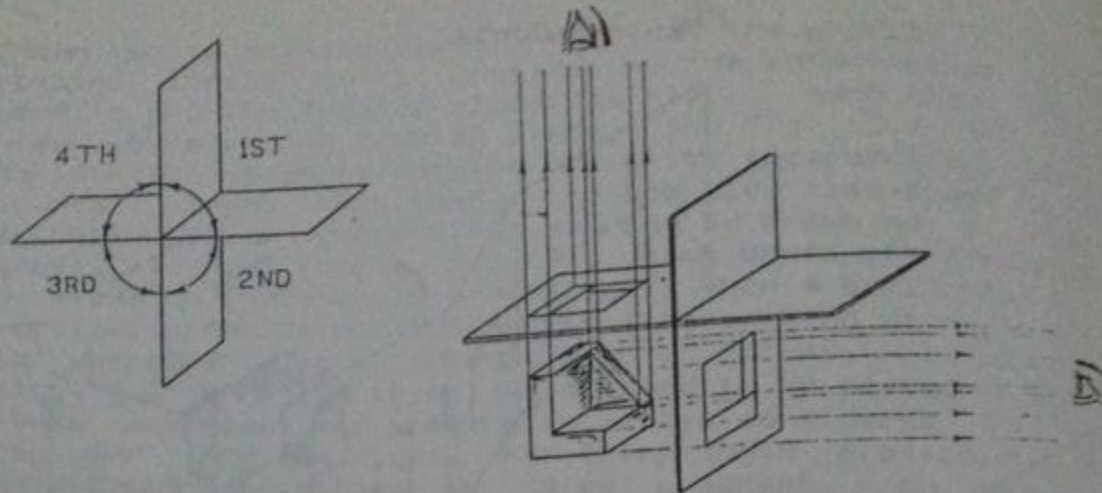
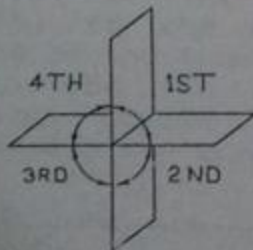

Fig. 3.8 Object Placed in 3rd Quadrant.

To summarize, in third angle projection, front view is always drawn at the bottom, top view just above the front view, and end view is drawn on that side of the front view from where we are looking at the end of the object relative to the front. L.E.V should be accommodated on the left of F.V while R.E.V on the right of F.V, however, one E.V is generally drawn.



A - Object placed in 1st quadrant

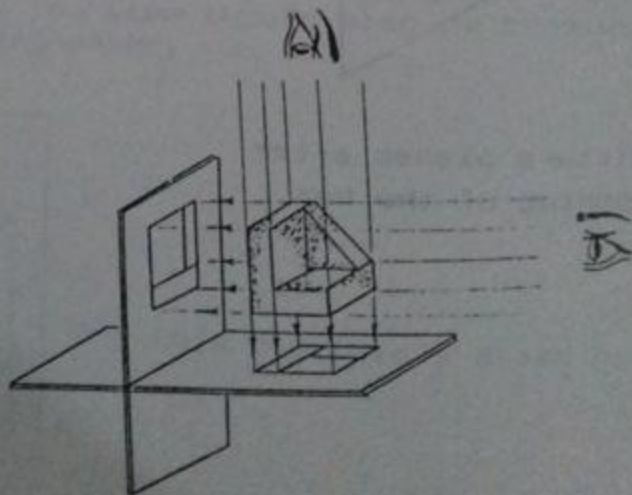
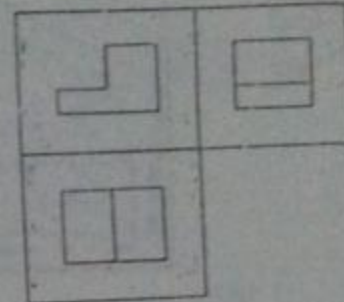
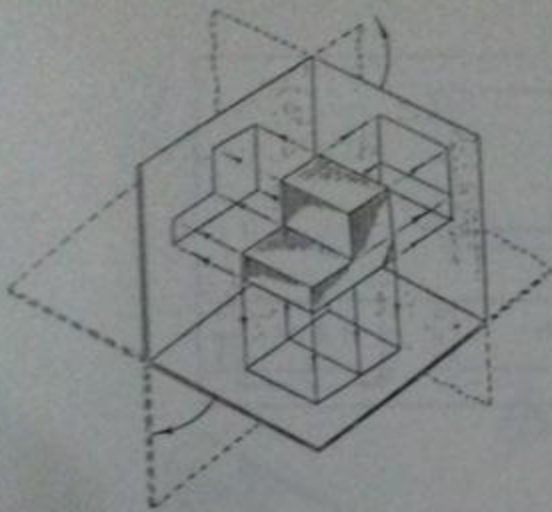

Fig. 3.9 Arrangement of Views in 1st Angle Projection.

Fig. 3.9 Contd.



C - Final arrangement of views on the drawing

B - Views formed on the picture planes

For first angle projection, the object is positioned in first quadrant as shown in Fig. 3.9 (A) and, hence, the object is considered to be inbetween the picture plane and the observer. After forming the views on the three planes, as shown in B-part of the figure, the top and the end views are rotated through 90° as before until they come in the frontal plane giving the final arrangement of views as shown in C-part of the figure. Top view is drawn at bottom of the

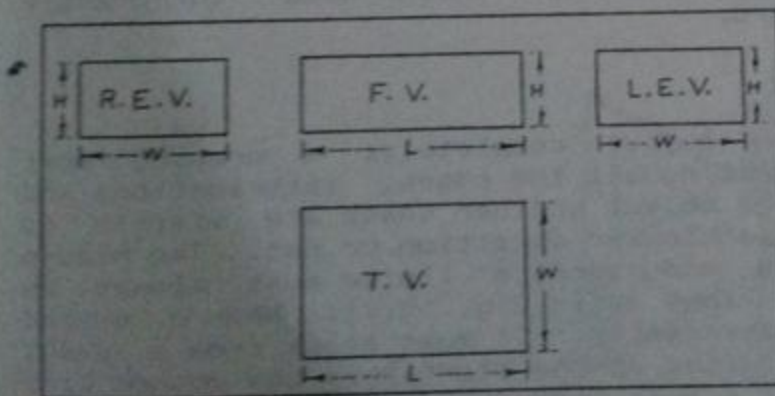

(A) 1st angle

Fig. 3.10 Summary of 1st and 3rd Angle Projections.

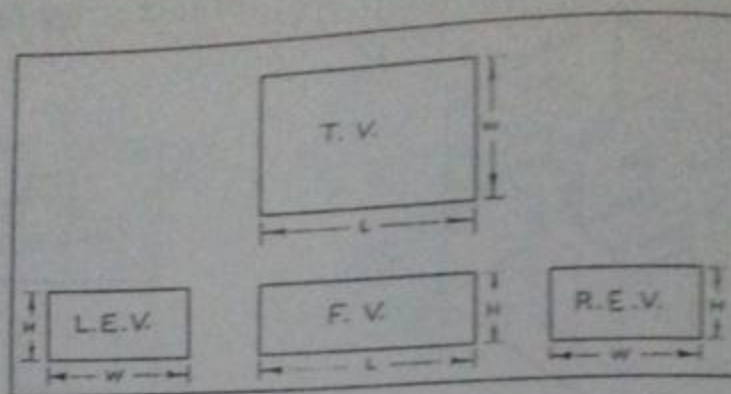

Fig. 3.10 (B) 3rd angle

paper, front view just above it and end view is drawn on that side of the front view which is opposite to the side from which we are looking at the object relative to the front.

First-angle projection was originally used all over the world but now in countries like the United States and Canada, third-angle projection is standard. In Pakistan, we use first angle projection for building drawing because all of the previous drawings for important buildings still lying in the offices are according to this method. For machine drawing, more trend is to use third-angle projection because of its convenience and because most of the machines are imported from those countries which have third-angle projection as standard.

3.11 HIDDEN FEATURES

To describe an object completely, a drawing must contain lines representing all the edges, intersections and surface limits of the object whether these are visible to the observer from a particular direction or not. The hidden edges, intersections and surface limits must always be indicated by dashed lines as in Fig. 3.11. When a dashed line is to start independently, it must start from a dash; however, a gap is provided at the start when the dashed line is in continuation of a full line.

In Fig. 3.12, there are three features added to a simple solid rectangular block, a raised rectangular head, a slot on the front and a drill starting from the right side

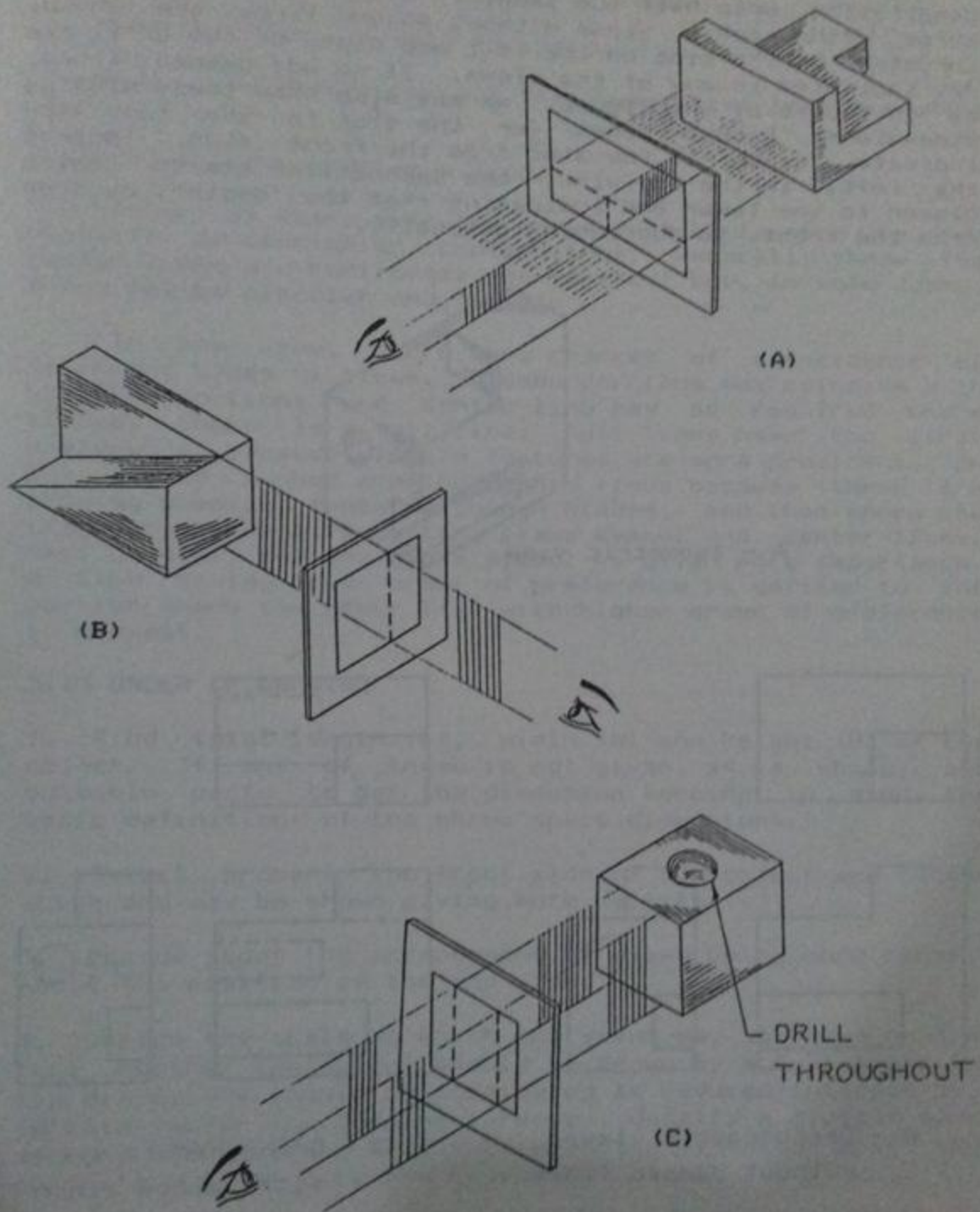
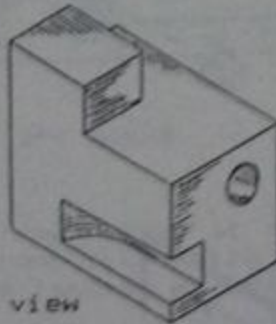
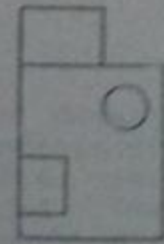
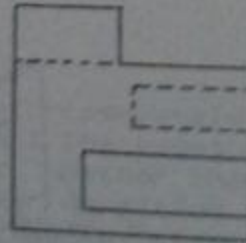
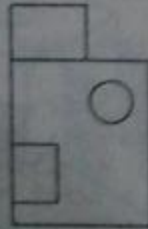
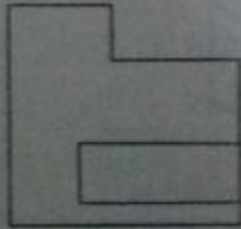
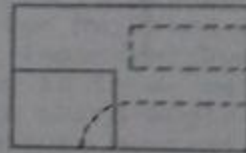
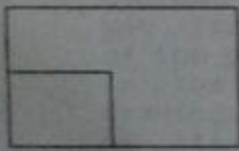

Fig. 3.11 Hidden Features.

penetrating upto half the length. In part-B of the figure, three orthographic views without dashed lines are shown. Curvature of the slot on the left and depth of the drill are not indicated in any of the views. If we add dashed lines, as in C-part of the figure, we may also show these missing dimensions. Dashed lines for the slot in the top view indicate "depth" of the slot from the front side. Towards the left, in the top view, the dashed line starts coming closer to the lower end indicating that the "depth", as seen from the front, is decreasing gradually.



A - Isometric view



B - Orthographic views without dashed lines

C - Orthographic views with dashed lines

Fig. 3.12 Importance of Showing Hidden Features.

3.12 CENTER-LINES AND PRECEDENCE OF LINES

Center-lines are used to indicate the following:

1. Axes of symmetry for all the symmetrical portions of a view.
2. Axis of a cylinder or a cone.
3. Center of every circular curve must be located by two mutually perpendicular center-lines. Generally these two center-lines are horizontal and vertical but, in some cases, these may be circular and radial.

In any view, there are chances of coincidence of different types of lines. Hidden portions may coincide with visible portions and center-line may be required where already there is a full line. Full lines have the first preference because visible features are more prominent, on the second number are the dashed lines because these are showing physical features though hidden, and then comes the imaginary lines like cutting plane symbol and center-lines. Most commonly cutting plane symbol is given more importance. A line having lower order of preference is omitted in the portion where the other line with higher order of preference is present.

3.13 ORDER OF DRAWING

1. Find total length (L), width (W) and height (H) of the object. If any of these is not given as a whole, add suitable parts to get the dimension keeping in mind the basic definitions of the three space dimensions.
2. Select properly the front side of the object and decide which end may be shown giving more details.
3. Decide about the arrangement of views being more careful about the position of the end view.
4. Decide the scale at which the views may be drawn meaning that whether the object should be drawn by actual sizes or the dimensions should be considered as reduced/inlarged by a certain factor for drawing purposes. Usually a minimum space of one inch must be left inbetween the views to make them separate and to write the dimensions.
5. Adjust the views in the space available as shown in Fig. 3.13. If three views are to be made, horizontal dimensions required are always length and width. On bottom

line of the space for the problem, measure a distance equal to $(L + W)$ from the left corner and divide the remaining space into three equal parts. Start from the left again, first leave a gap equal to one part, measure L or W depending upon whether F.V or E.V is to be drawn on the left, leave a gap equal to one part, measure the other dimension, and then check whether remaining one part is left on the right or not. Draw vertical construction lines from these points. Similarly divide vertically the left line of the space. Measure a distance equal to $(H + W)$ and divide the remaining space into three equal parts. Leave one part at the top, one part at the bottom and one part inbetween the views. Draw horizontal construction lines from the points so obtained.

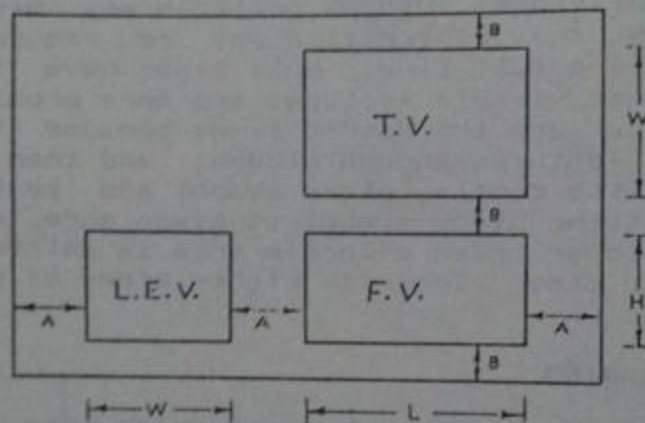

Fig. 3.13 Arrangement of Views in a Given Space.

6. Rub out the extra lines to obtain rectangular blocks for the three views.
7. Draw all those center-lines firm for which dimensions can readily be found out.
8. Start showing the features one by one and carry the different views along together as far as possible. If there are some dimensions which are not directly given, start with any of the views and complete it upto the stage where some missing dimension is needed. Leave that view incomplete and start with any of the other views completing it upto the point where again some dimension is missing. Start with the third view. The unknown dimension will be indirectly found out in any of these views which may then be used to complete the other views.

9. Remove extra lines, give dimensions and check the views before the final presentation.

3.14 TRANSFERING DIMENSIONS IN BETWEEN THE VIEWS

During drawing work, avoid duplication of laying down the same measurements. Height dimensions may easily be transferred among the front and the end view with the help of the T-square as shown in Fig. 3.14 (A). Similarly length dimension may be transferred among the top and the front view by using a combination of any triangle and T-square as

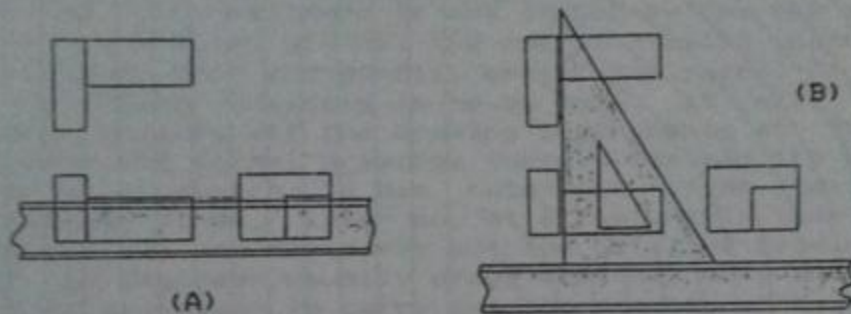

Fig. 3.14 Transfer of Length and Height Among the Views.

shown in Fig. 3.14 (B). Width dimension may be transferred among the top and the end view in four different ways. First, if we know the measurement in one of the views, we may transfer it to the other view using a suitable scale. Second, the dimension may be transferred by using a divider as shown in Fig. 3.15 (A). Third, a 45°-line may be drawn

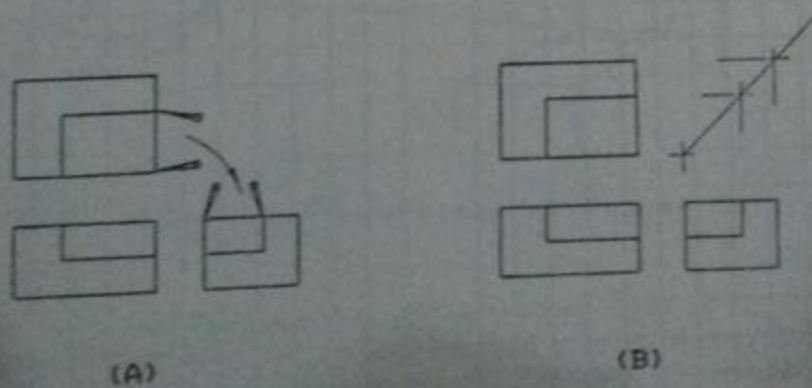
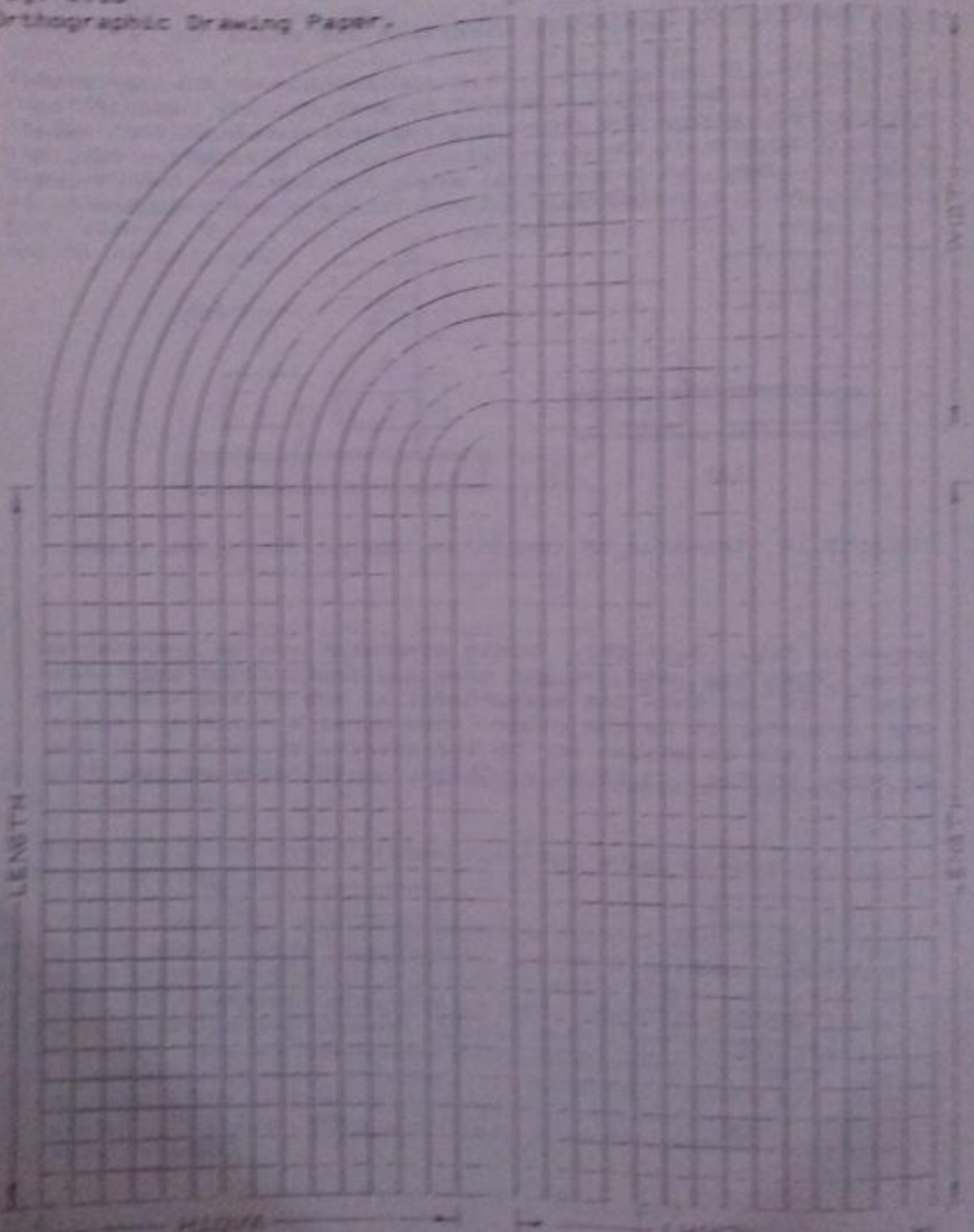

Fig. 3.15

Fig. 3.16
Orthographic Drawing Paper.



62

from the intersection of the construction lines extended from the inner side of the E.V and lower side of the T.V, as shown in Fig. 3.15 (B), the dimension is then transferred by taking vertical projection from the E.V to the 45°-line and then horizontal projection to the T.V or vice versa. Fourth, we may use an orthographic drawing paper in which width dimension is transferred by a curve as shown in Fig. 3.16.

3.15 FREEHAND SKETCHING

A freehand sketch is a drawing in which all the proportions and measurements are judged by the eye and all the lines are drawn without the use of drawing instruments; the only tools used are pencil, eraser and paper. If drawing of an existing building is to be made, it will not be possible to carry all the drawing instruments at the site and to make the formal drawings there. Instead the engineer will make a sketch in his note-book after taking the measurements, then, later on, at a favourable time sitting in his office, he may carry out the detailed drawing work. Further an engineer usually draws sketches only and it is the job of draftsmen to carry out the drawing work. Sketches should be made such that they are easily readable by the same person and by the others. Following points may be kept in mind while making sketches:

1. All the dimensions should be in some proportions that means bigger dimensions should actually be bigger than the smaller ones. If a pictorial view is provided, it may be enclosed in a rectangle and divisions of a suitable length may be marked on it to judge the proportions. If the object is bigger one like a building, the proportions may be

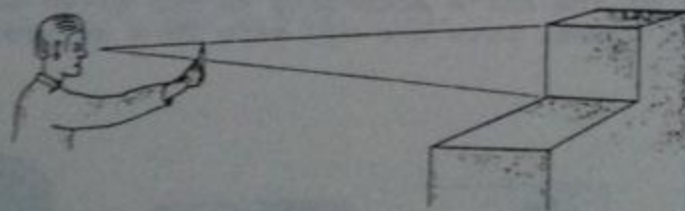

Fig. 3.17 Guessing Proportions of Bigger Objects.

estimated by the procedure illustrated in Fig. 3.17. A pencil is held in the fully stretched right hand. End of the pencil is coincided with the start of the dimension to be estimated and the dimension is marked on the pencil with the tip of the thumbnail. Depending upon size of the paper this

dimension may be enlarged or reduced. The other dimensions may be estimated in the same way which must also be enlarged or reduced by the same factor. This method enables the working person to maintain the ratio between all the dimensions.

2. Straight lines should be as straight as possible, multistroke lines are generally used for the bigger lengths.

3. To draw a circle, first sketch the center-lines, then draw the 45° construction lines as shown in Fig. 3.18. By guess, mark a distance equal to radius on all these lines and join by a smooth curve.



Fig. 3.18 To Draw Freehand Circle.

3.16 MODELS

Models of a simple object may easily be made in modeling wax, soap or wood. For soap models, rectangular block of soap having a size close to 1.5" x 1" x 1" may be used. First proportions of the object are marked lightly with the point of the knife according to the given pictorial or orthographic views. Cuts are now made in a suitable order

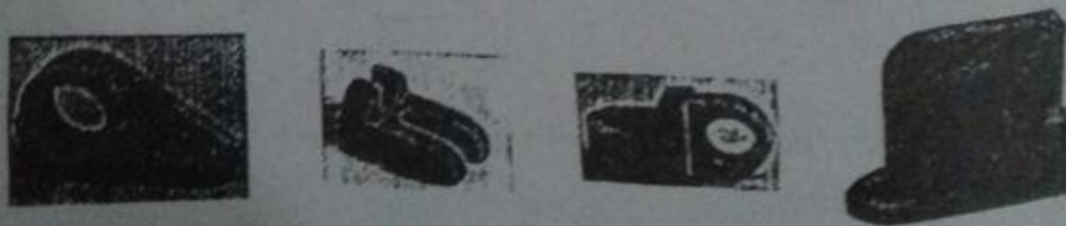

Fig. 3.19 Soap and Wooden Models.

to obtain the model as shown in Fig. 3.20. Some objects should first be divided into basic geometric shapes which are made separately and then these parts are combined in the required pattern.

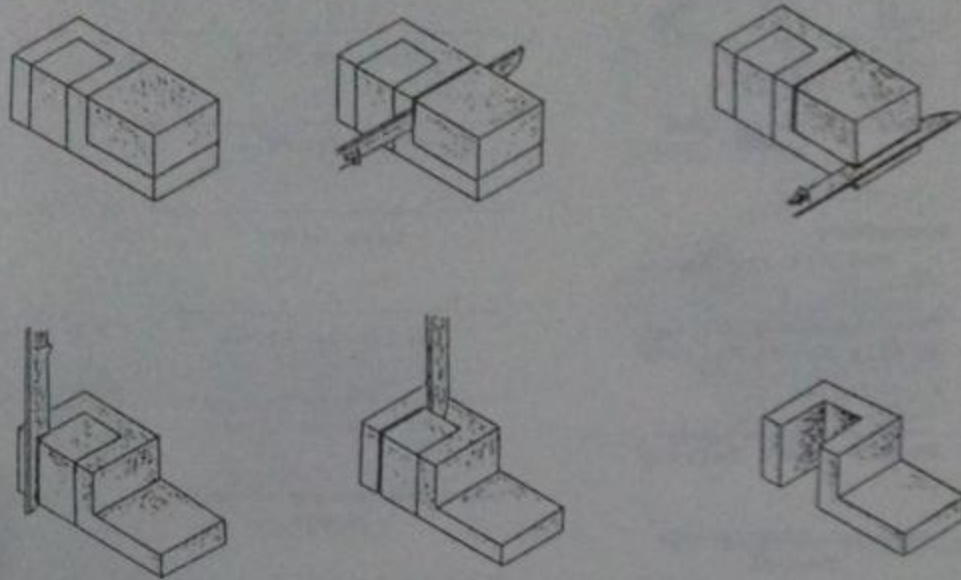
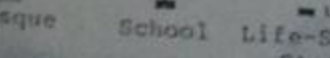
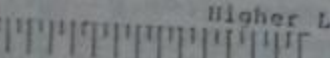
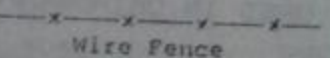
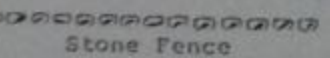
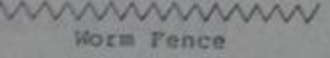
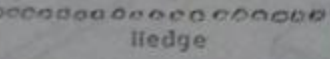
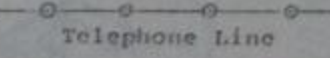
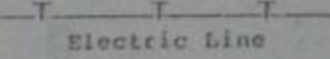
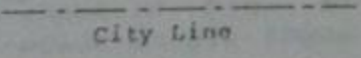
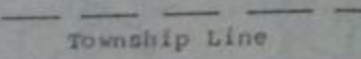
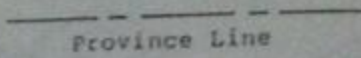
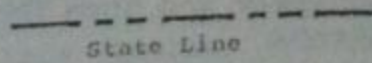
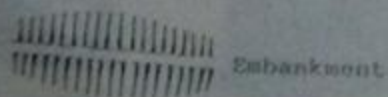
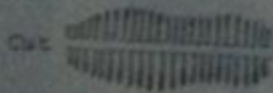
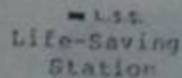
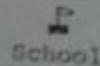
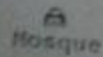
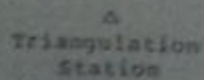
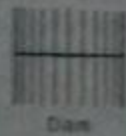
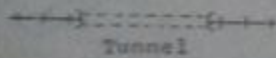
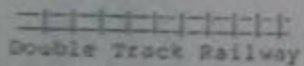
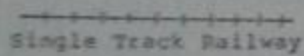
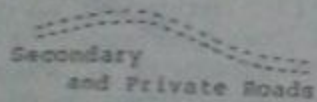
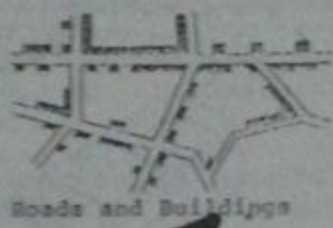

Fig. 3.20 Procedure for Model Making.

3.17 SYMBOLS USED IN ORTHOGRAPHIC DRAWING

For drawings made on very reduced scales like survey maps or for some types of working drawings, we use different symbols to save time and to clearly communicate the feature. These symbols are shown in Fig. 3.21.

Fig. 3.21 Orthographic Symbols Used in Civil Engineering.



A) Symbols for Man-Made Features

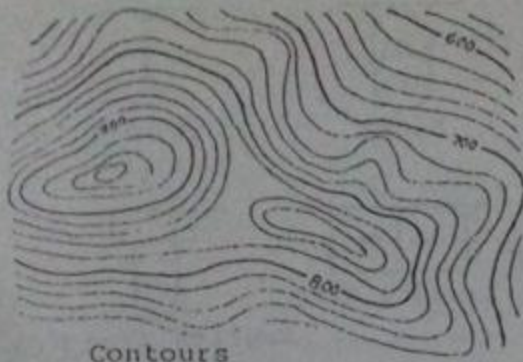

Contours



Sand Dunes

© 678.25

Determined
Elevation



Mud Flat



Hill Shading

B) Survey Symbols

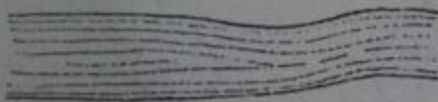

Stream



Lake or Pond



Canal



Dry Lake



Fresh Marsh



Submerged Marsh

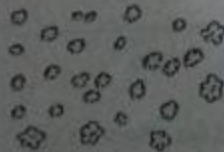

Trees

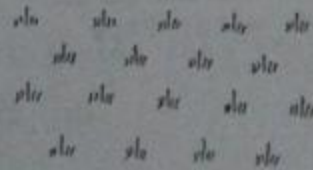

Grass or Plantation

C) Symbols for Water Features

67

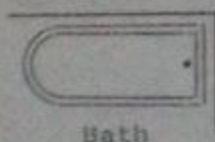

Bath



Foot Bath

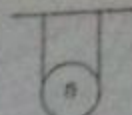

Bidet

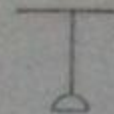

Shower

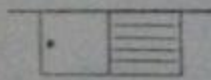

Sink

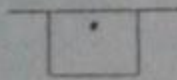

Wash Hand Basin
(WHB)

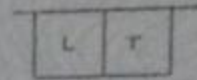

Laundry Tray

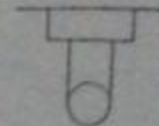

English Type W.C.

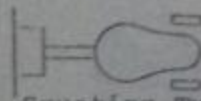

Squating Type W.C.
or Indian Water Closet

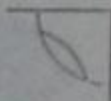

Urinal

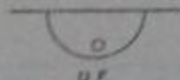

Drinking
Fountain

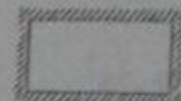

Overhead
Water Tank

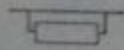

Paper Roll



Flow Trap

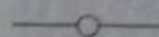

Vent Pipe



Gully Trap



Man Hole
or Cleaning Chamber



Cleanout



Hot Water Tank



Water Heater



Meter



Water Tap



Gas Outlet



Service Pipe

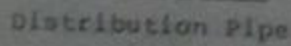

Distribution Pipe

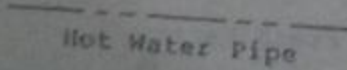

Hot Water Pipe

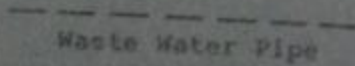

Waste Water Pipe

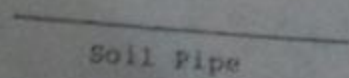

Soil Pipe

D) Standard Plumbing Symbols

10

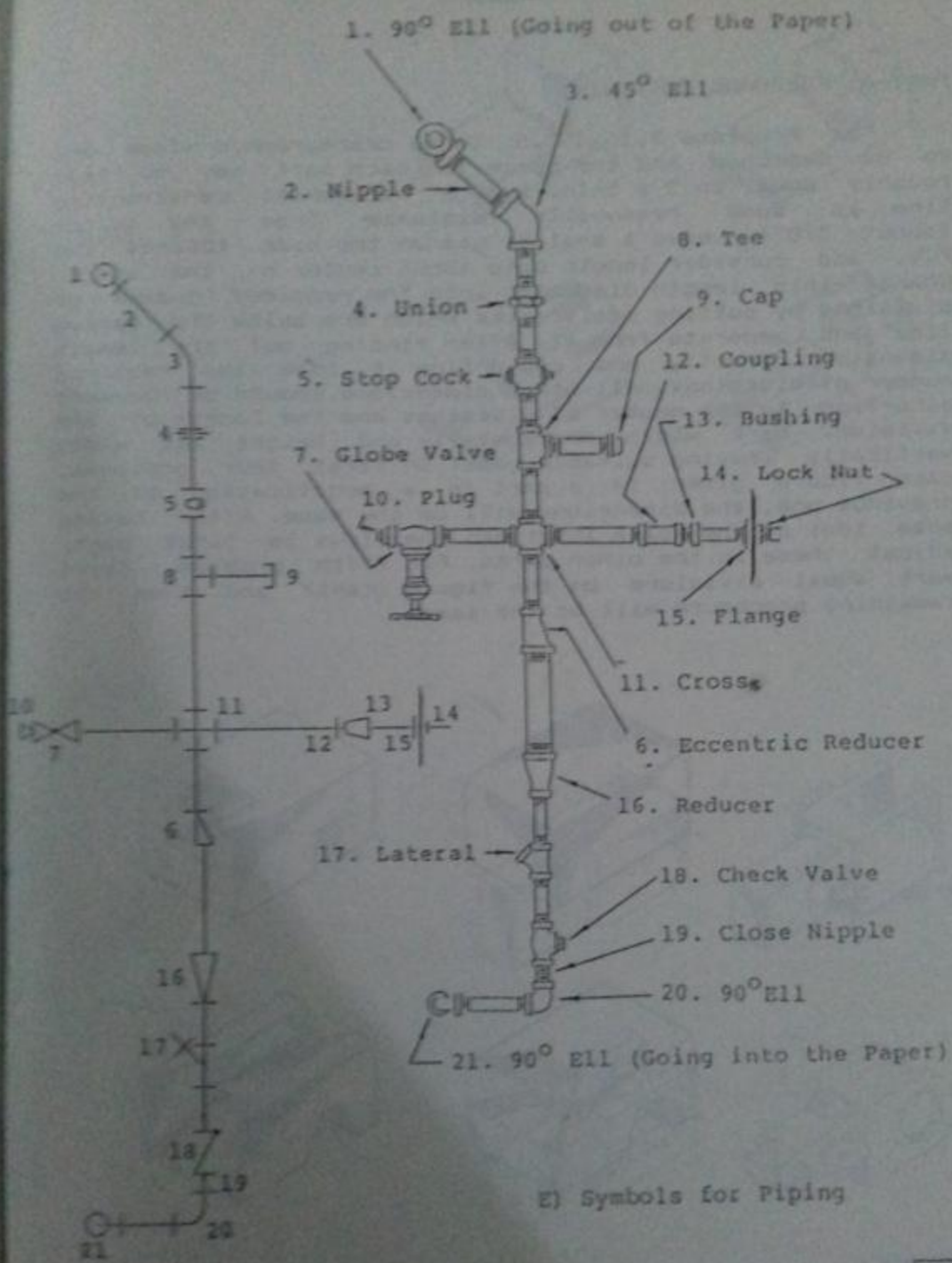

PROBLEMS

PART-A: FREEHAND SKETCHING

For Problems 3.1 to 3.5, three orthographic views are to be sketched and the space for each part may be kept roughly equal to 5 x 5-in. Draw a horizontal construction line at some reasonable distance from the bottom (about 3/8"). Leave a smaller gap on the side towards the F.V. and consider length upto about center of the space. Change this length dimension into the required number of divisions by putting small marks which are below the marked line and separate from it. After finding out the length dimension directly and converting it into the required number of divisions, all other dimensions should be guessed according to the number of divisions and the length of one division. Mark width horizontally and height and width vertically leaving suitable gaps. In first four problems, each figure given in a part is a modification of the previous one, the dimensions will be the same. After having some idea of the space inbetween the views in first part, adjust these in the other parts. For fifth problem, first mark equal divisions on the figure itself and then the remaining procedure will be the same.

Prob. 3.1

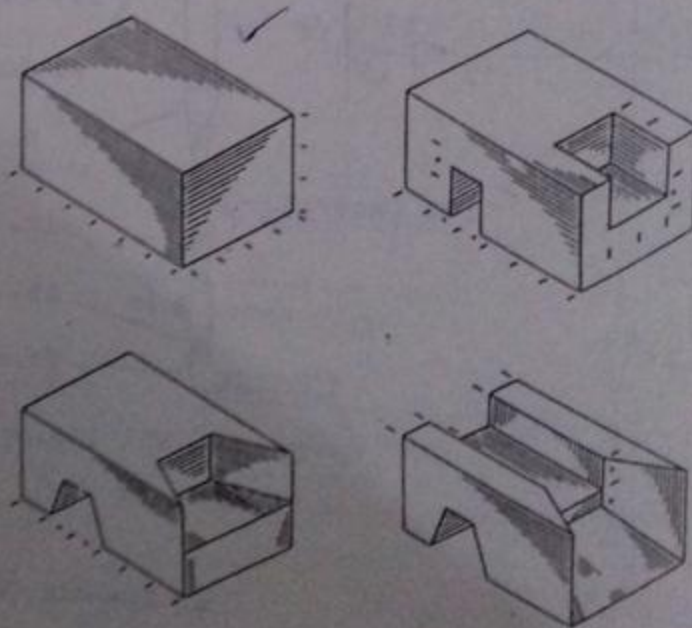

Prob. 3.2

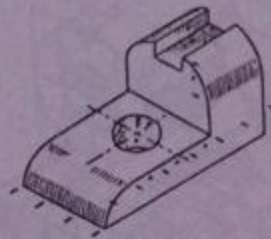
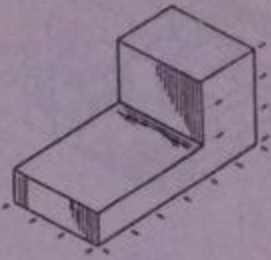

Prob. 3.3

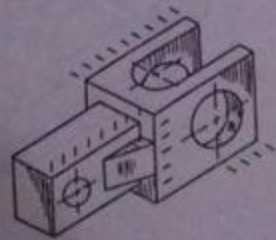
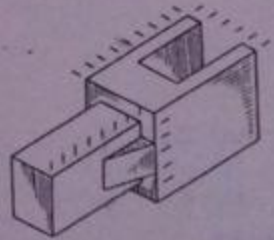
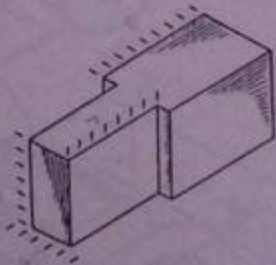

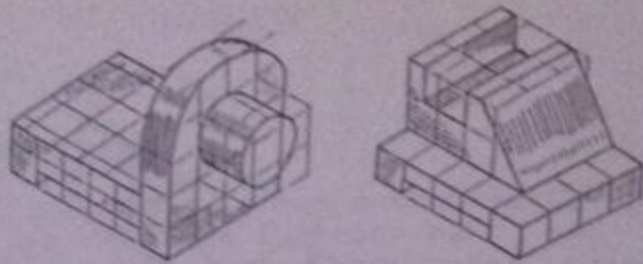

Prob. 3.4

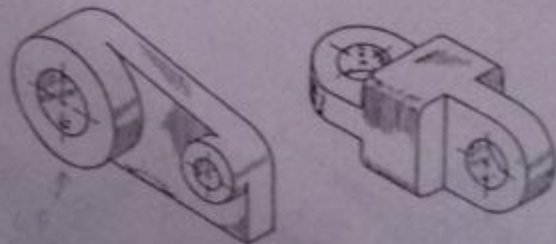
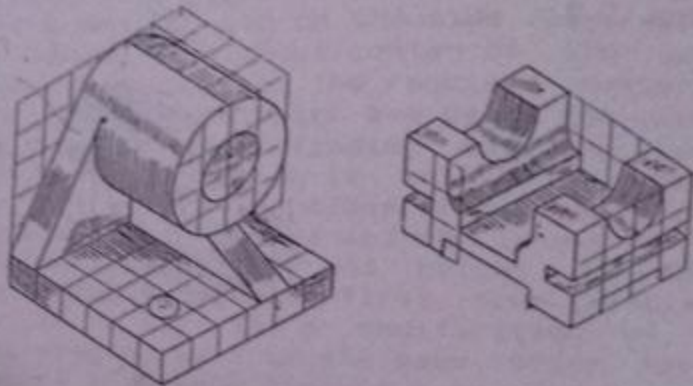

Prob. 3.5



PART-B: ORTHOGRAPHIC DRAWING

For the following figures provided, draw three orthographic views according to 1st or 3rd angle projection as recommended by the teacher.

Prob. 3.6

INCH UNITS

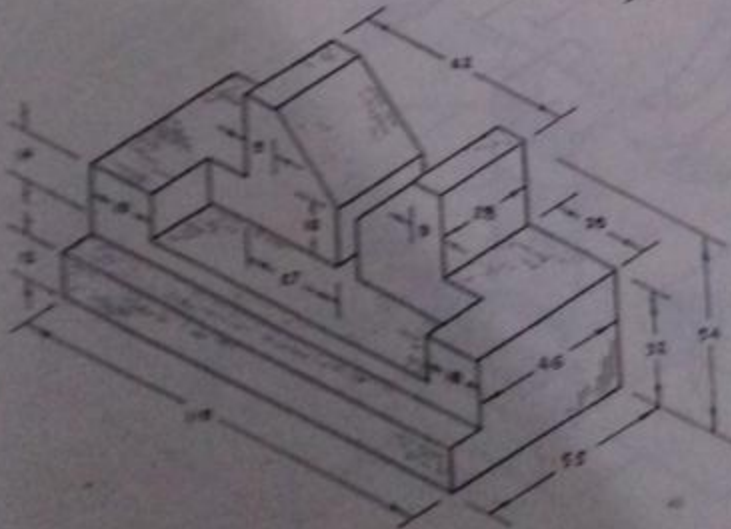
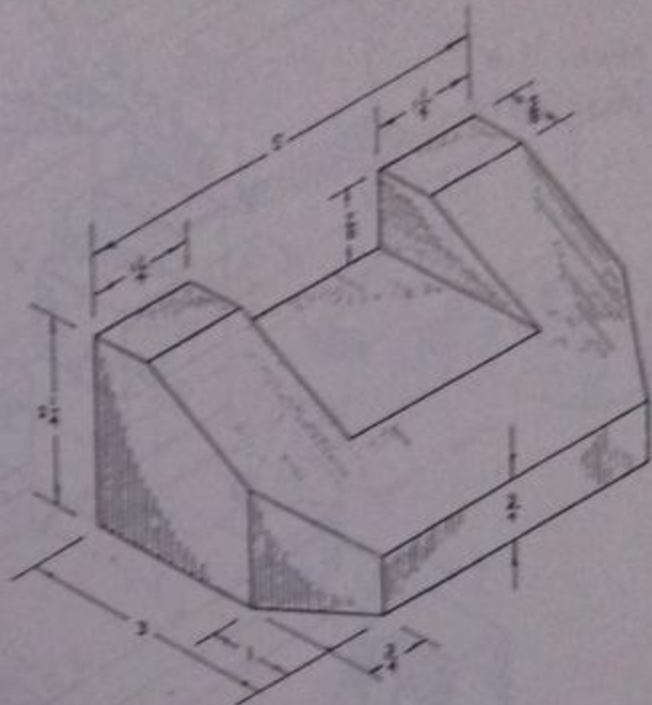

Prob. 3.7

METRIC

5

Prob. 3.8
INCH UNITS

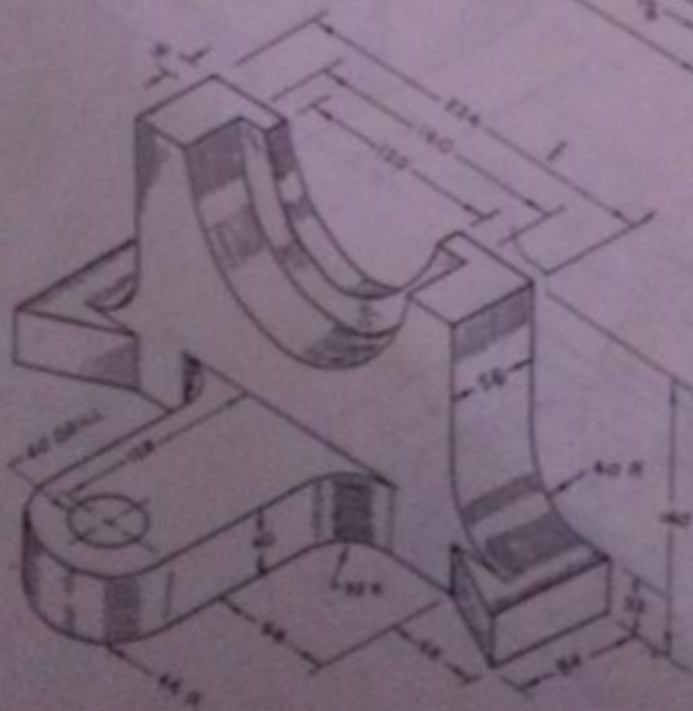
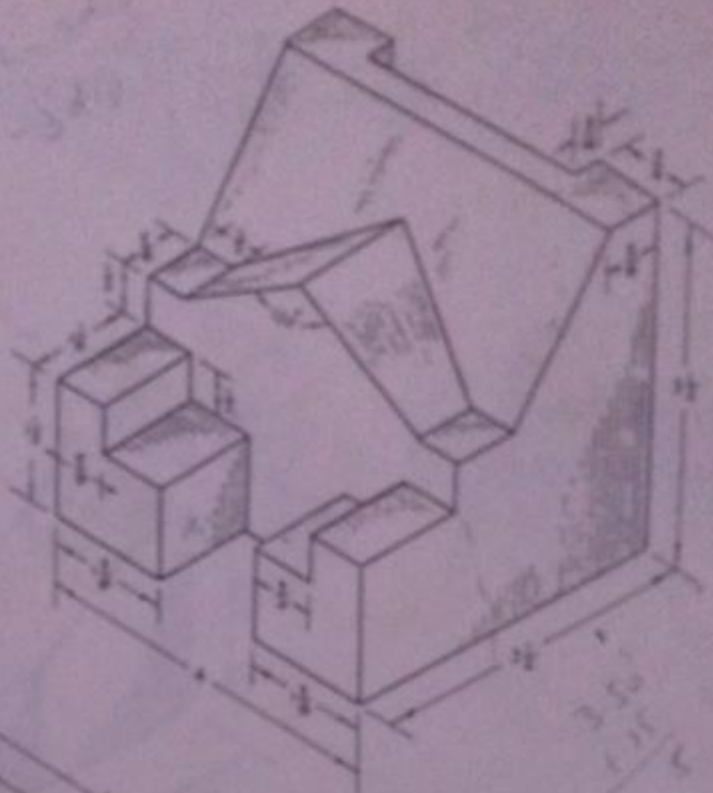

Prob. 3.9
METRIC

Prob. 3.10
INCH UNITS

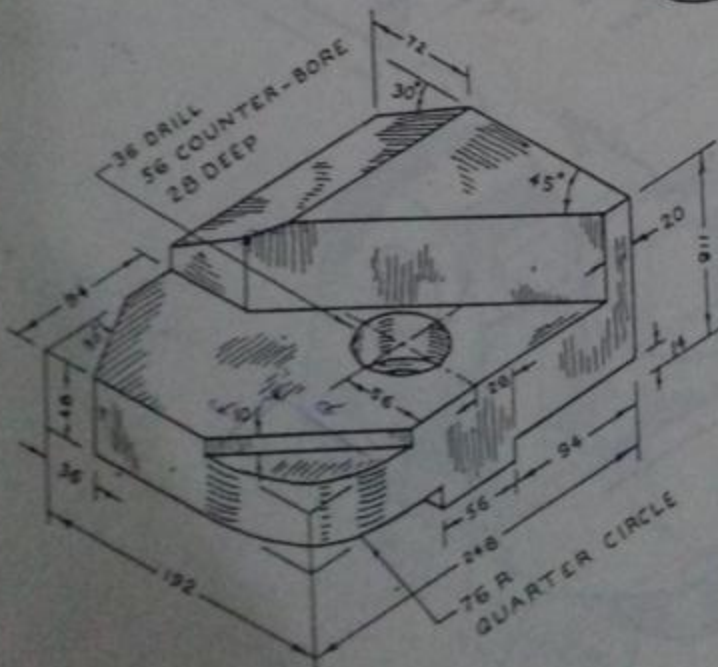
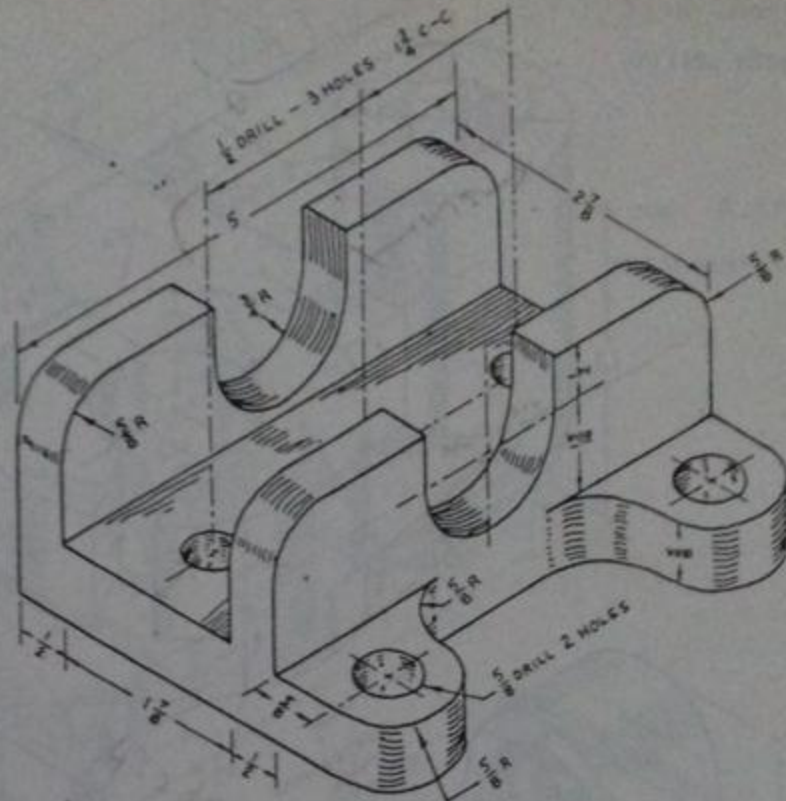

Prob. 3.11
METRIC

Prob. 3.12

INCH UNITS

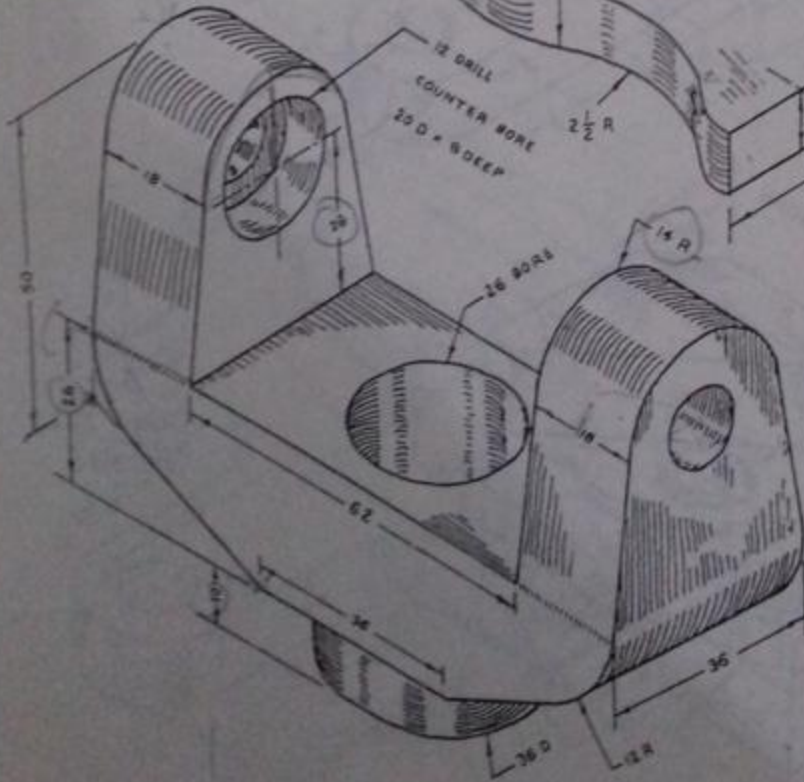
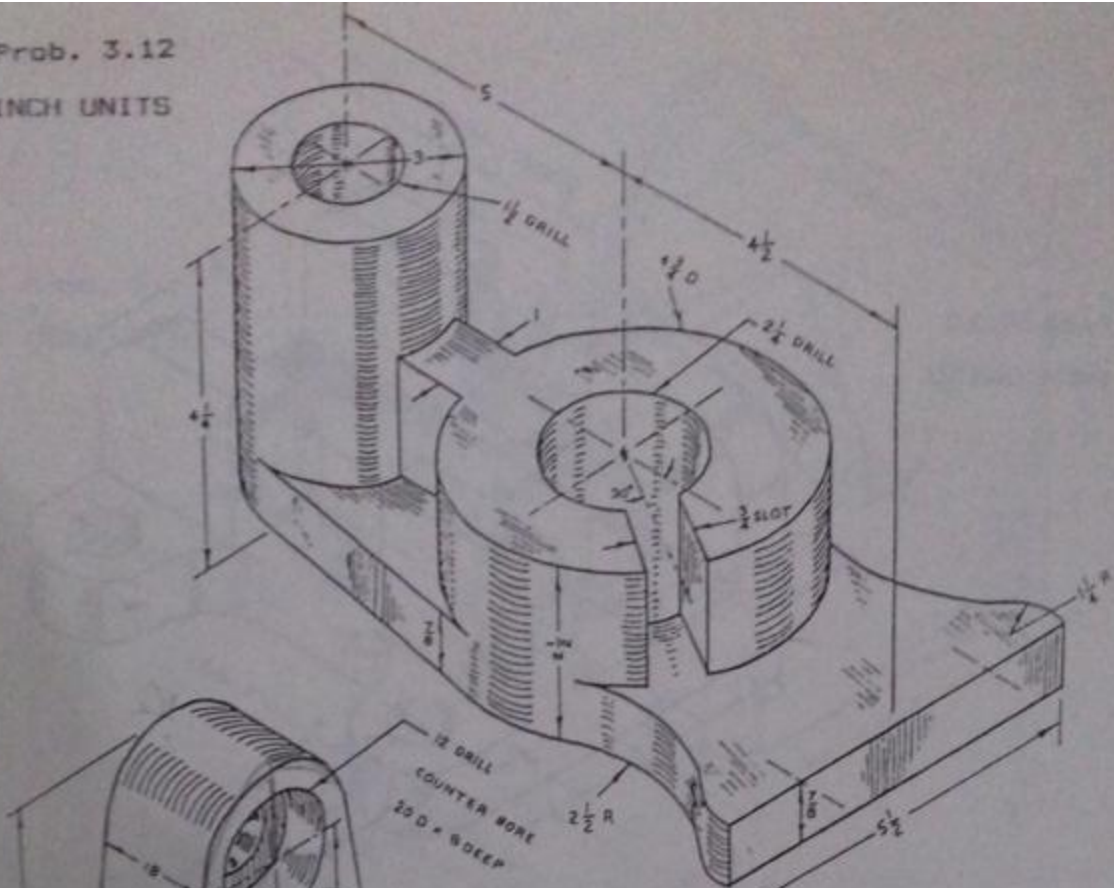

Prob. 3.13
METRIC

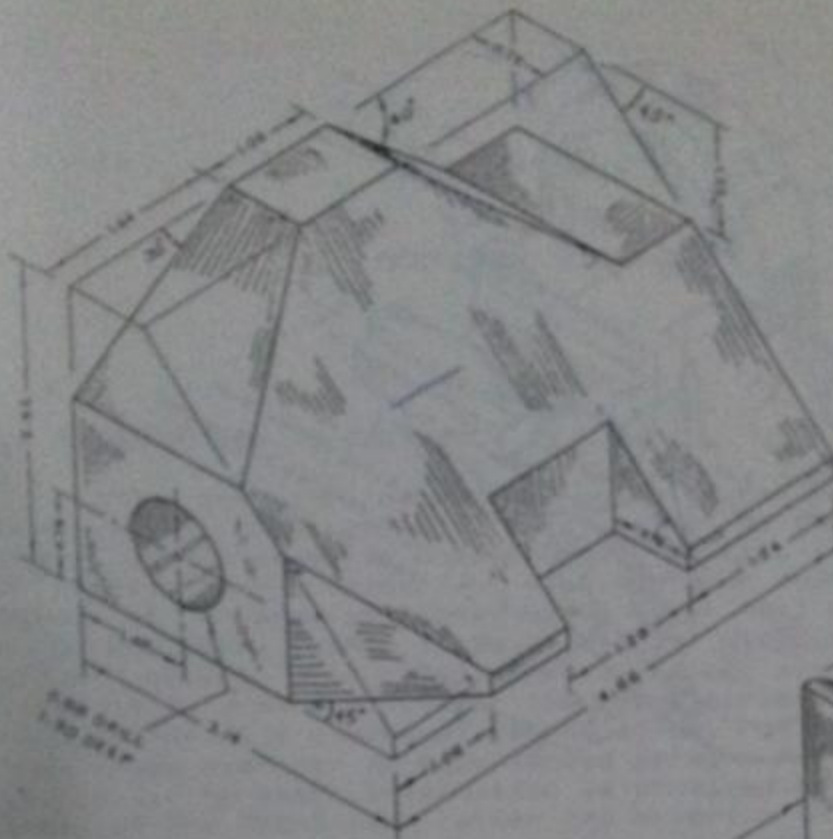

Prob. 3.14

INCH UNITS

Prob. 3.15

METRIC

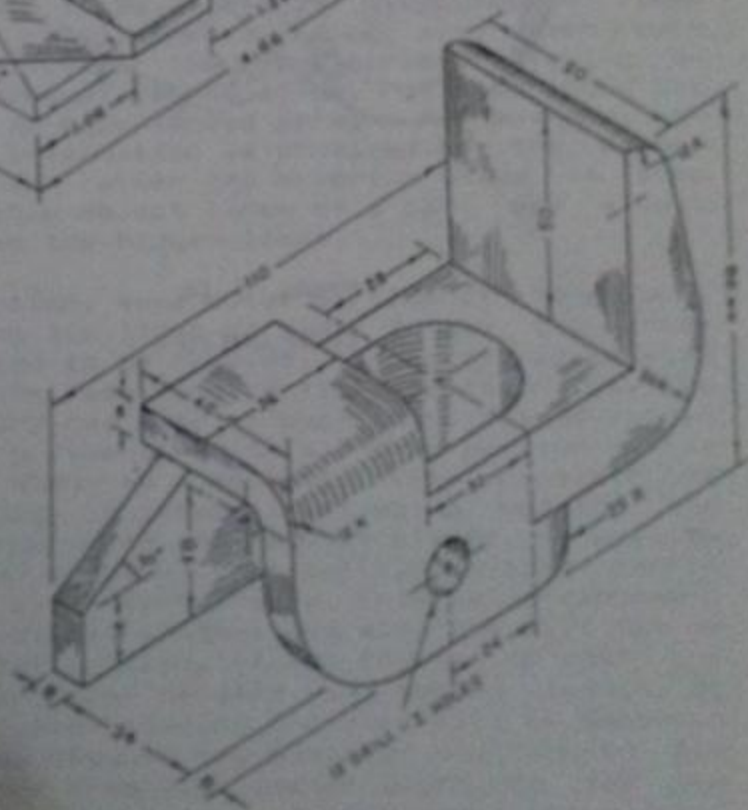

CHAPTER NO. 4

SECTIONAL VIEWS

4.1 INTRODUCTION TO SECTIONS:

There are two methods by which we can describe the inner shape of an object. First method is to use dashed lines, as explained in Chapter No.3, but it is only valid for objects having lesser and simple hidden features. Second method is to draw sectional views which will be discussed in detail here. Dashed lines in regular orthographic views for an object with complicated interior are often much difficult to draw and further the views become confusing by the presence of a number of dashed lines, not describing the inner shape even for an experienced person. For example, in Fig. 4.1, no extra information is provided by the dashed lines of the front view rather the exterior shape is also disturbed. The visible object lines of a part are always easier to be read than the hidden lines.

In case of a section, some outer portion of the object, which is obstructing the lines of sight to see the inner details, is considered to be removed. An orthographic view is then drawn for the remaining portion. Section may be defined as an imaginary cut made through an object to expose the interior shape. A view in which all or a portion of the view is sectioned is known as a sectional view. Consider the example of a building. A person is standing outside the building having all the doors and windows closed. He will be able to see the outer shape of that building but he cannot have an idea of what is present inside. Internal arrangement of rooms, furniture, doors, windows and almirahs will not be clear in a simple exterior view. If now the person opens the door, some of the interior details will become visible to him. The view formed after opening the door will be somewhat like a sectional view because the observer has removed the material of the door from his line of sight to see the interior. Another common example is from biology where inner parts of various organisms are required to be shown. To see

the inner details of a stem or a leaf, etc., a cut is made longitudinally or transversely removing one part while the remaining part is orthographically drawn to obtain a longitudinal or a transverse section. The view may either be obtained by naked eye and drawn on full scale or it may be taken using a microscope and drawn on an enlarged scale. Similarly if any fruit is cut into two parts, inner shape like arrangement of seeds may easily be seen.

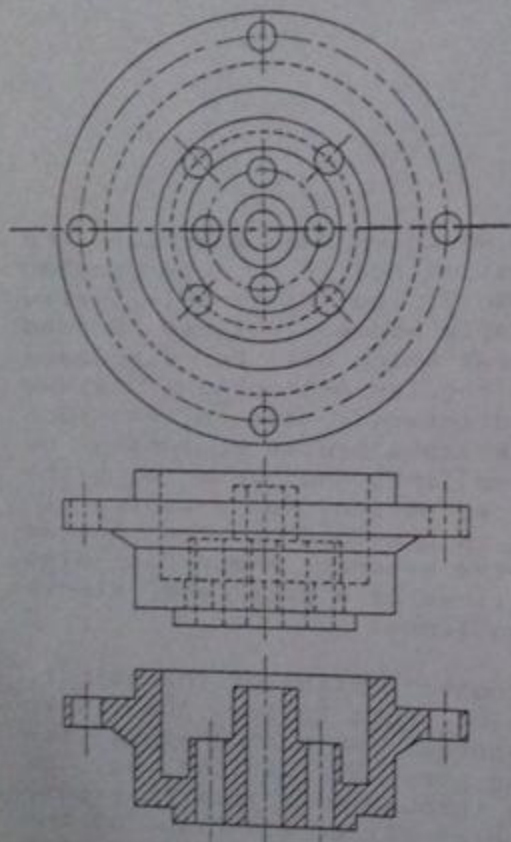

Fig. 4.1
Complicated Hidden Features

(A) Hidden Details Shown
by Dashed Lines

(B) Sectional View

In Fig. 4.3, the process of cutting an object to obtain a section is shown. The imaginary medium used to show the path of cutting an object to make a section is known as cutting plane. The hidden surface limits of the drills after cutting become visible intersections and hence the dashed lines for simple orthographic view change to full lines in the sectional view. Further the solid portions at the level of cutting are also shaded to separate them from the empty spaces or voids. The sectional view thus obtained depends upon the position of cutting and a number of different sectional views are possible for an object from the same side, see Fig. 4.4. Hence, the position of the cutting plane

must always be specified for a sectional view otherwise it becomes meaningless. The cutting plane is shown on that orthographic view where it appears as an edge by its symbol as given in Chapter No.2. The cutting plane may be more completely identified with reference letters and indication

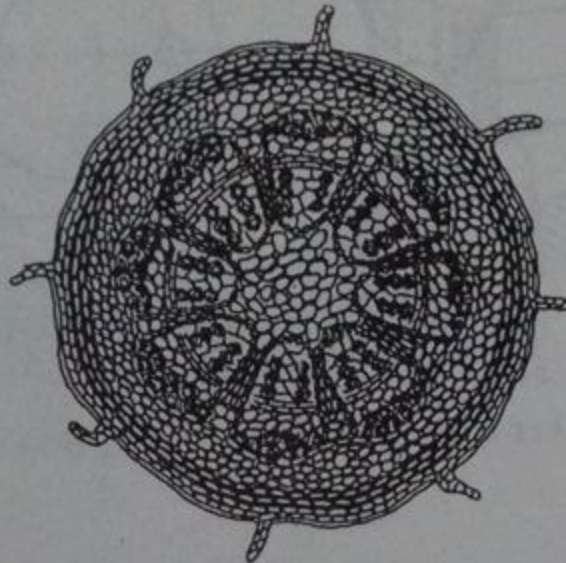

Fig. 4.2 Transverse Section of Stem of a Tree

of direction in which the view is taken. Generally, in building drawing, only the beginning, ending and the change of direction is marked for a cutting plane to avoid more lines in the view. Like center-line, cutting plane is purely imaginary and its symbol is usually extended from the view.

Solid metallic portions (made of Cast Iron) in sectional view are shown by section-lining, sometimes called cross-hatching. Very fine lines are drawn at 45° with the principal lines in the view at a uniform spacing varying from $1/16$ -in to $1/8$ -in. For bigger portions to be cross-hatched, spacing close to $1/8$ -in is used, whereas, for smaller portions, spacing close to $1/16$ -in is preferable. It is important to note that there are two types of solid materials which are shown in a section. The solid portions in the path of cutting are section-lined whereas the solids visible from behind the cutting plane are shown by their simple orthographic views.

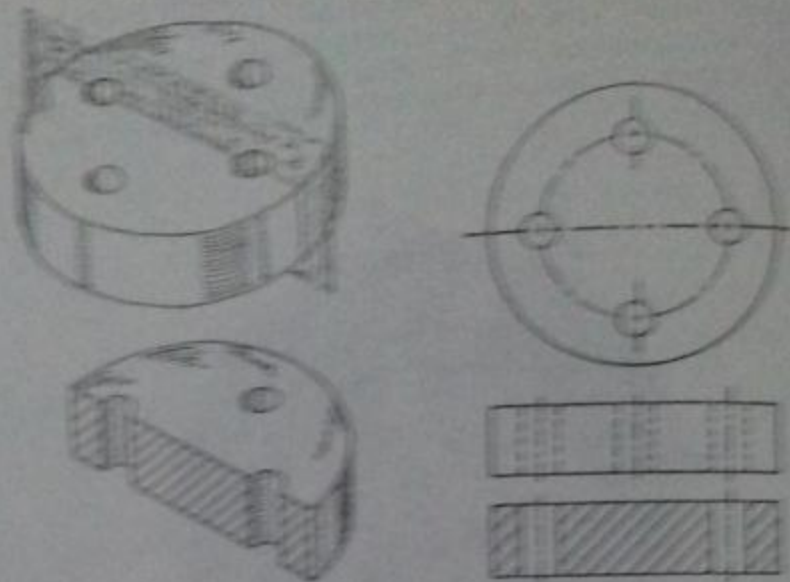

Fig. 4.3 Cutting Plane and Resulting Sectional View

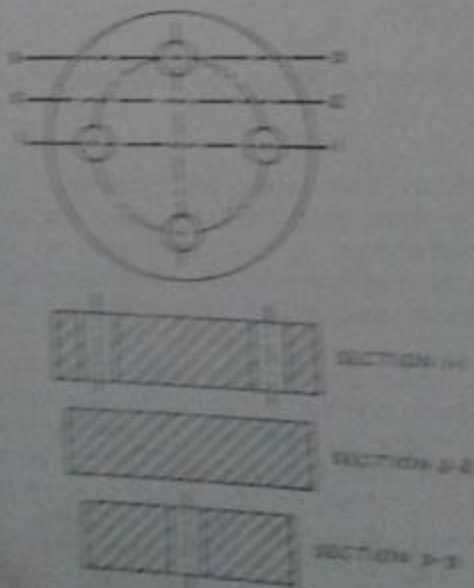

Fig. 4.4 Sectional Views for Different Cuttings

Spacing between the lines may easily be controlled by marking a line at the required distance over the 45°-triangle parallel to the 45° working edge. This line may be temporarily drawn with HB-pencil or it may be drawn permanently using needle of the divider. To draw section-lines, the triangle is placed over the T-square in correct

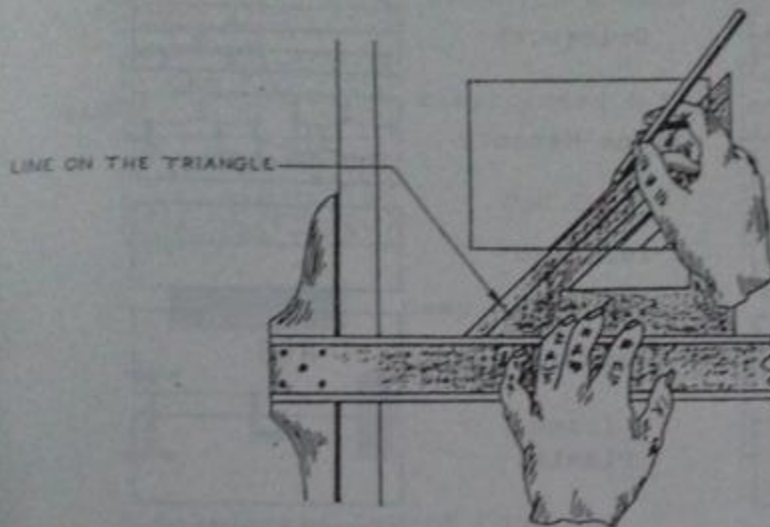

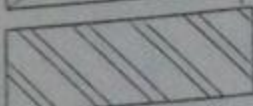
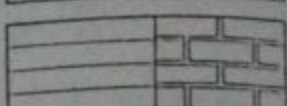
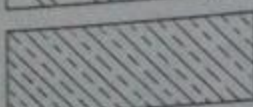

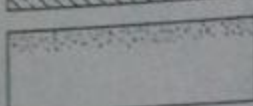
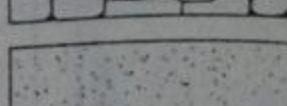
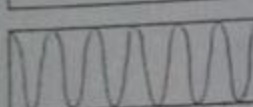
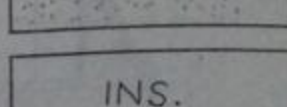
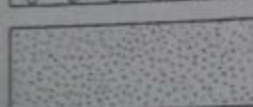
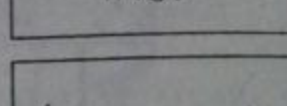
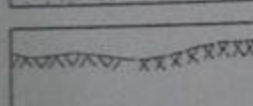
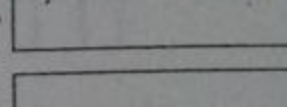
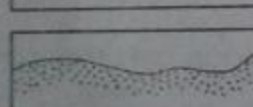
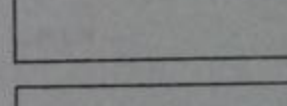
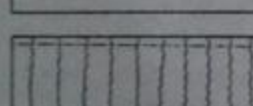
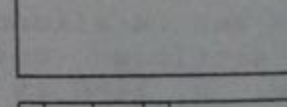
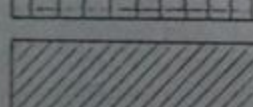
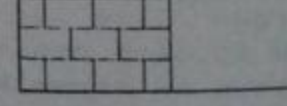
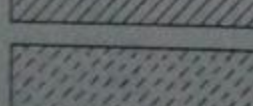
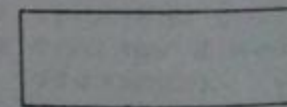

Fig. 4.5 Cross-Hatching

position and is slid until the first corner of the portion to be sectioned coincides with the marked line on the triangle. A line is now drawn by using the working edge, this drawn line is then coincided with the line on the triangle to give position of the triangle for the next line. The process is repeated until all the part is section-lined. In building drawing, there are a number of different symbols to represent various materials like brickwork, plain cement concrete (concrete without steel), reinforced cement concrete (concrete with steel), earth filling, sand filling, and various steel shapes, etc. Using these symbols in the sectional views, we can have an idea of the materials of construction even if these are not mentioned in writing.

Main advantages of sectional views are as follows:

1. Inner shape is clearly shown without any ambiguity.
2. For more hidden features at different positions inside the object, a number of cutting planes may be assumed and corresponding sectional views may be drawn separately.

SECTION		ELEVATION
	Wood	
	Brickwork	
	Stone Masonry	
	Terrazzo	
	Insulation	
	Plaster	
	Earth	
	Sand	
	Glazed Tile	
	Cast Iron	
	Glass	

Symbols for Building Materials

Fig. 4.6 Symbols for Building Materials in Elevation and Section

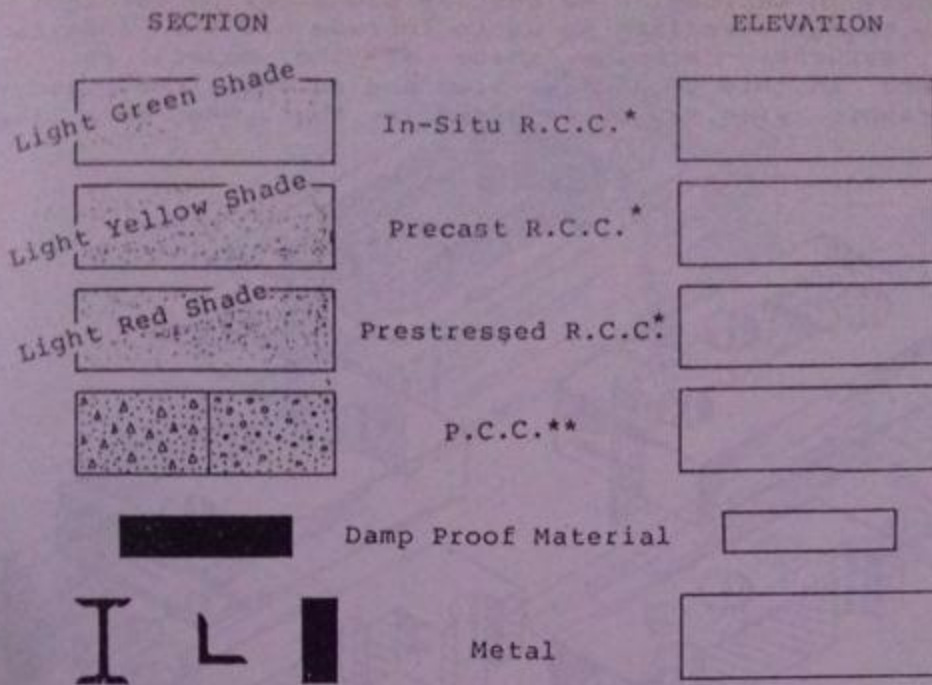

* Reinforced Cement Concrete

** Plain Cement Concrete

Fig. 4.6 Continued ...

3. The solid portions and the voids at the level of cutting may be distinguished.

4. Materials of construction are also communicated without writing in words.

5. Sections are often drawn to larger scales than that of the other views in order to show the minute dimensions more clearly.

4.2 TYPES OF SECTIONS:

Depending upon the path of cutting an object and the use of a particular sectional view, there are following types of sections:

4.2.1 Full Section:

A full section is one in which the cutting passes entirely across the object so that the resulting view is

completely in section. The cutting plane may be straight or it may change direction so as to include all the important inner features. Exterior shape of the object is not described in this type of section and an additional simple orthographic view may be required for that. When more than

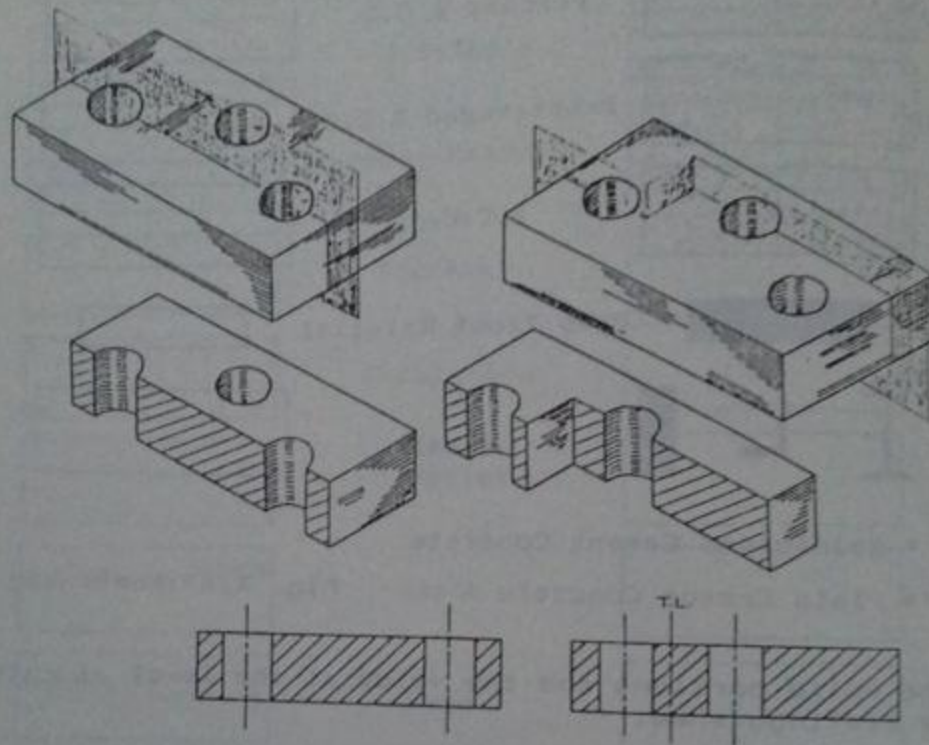

Fig. 4.7 Full Sections

one sectional views are to be drawn from different directions, the object is considered to be complete and independent of other cuttings for a particular cutting plane, as shown in Fig. 4.8. Part-B shows the portion remaining for one sectional view and part-C for the other sectional view, whereas, part-D is the orthographic drawing of the same object with the front and the side views shown as full-sectional views. The change in plane direction for an offset cutting plane is not shown on the sectional view by full line because the cutting is purely imaginary and actually no edge is present in the object at this position.

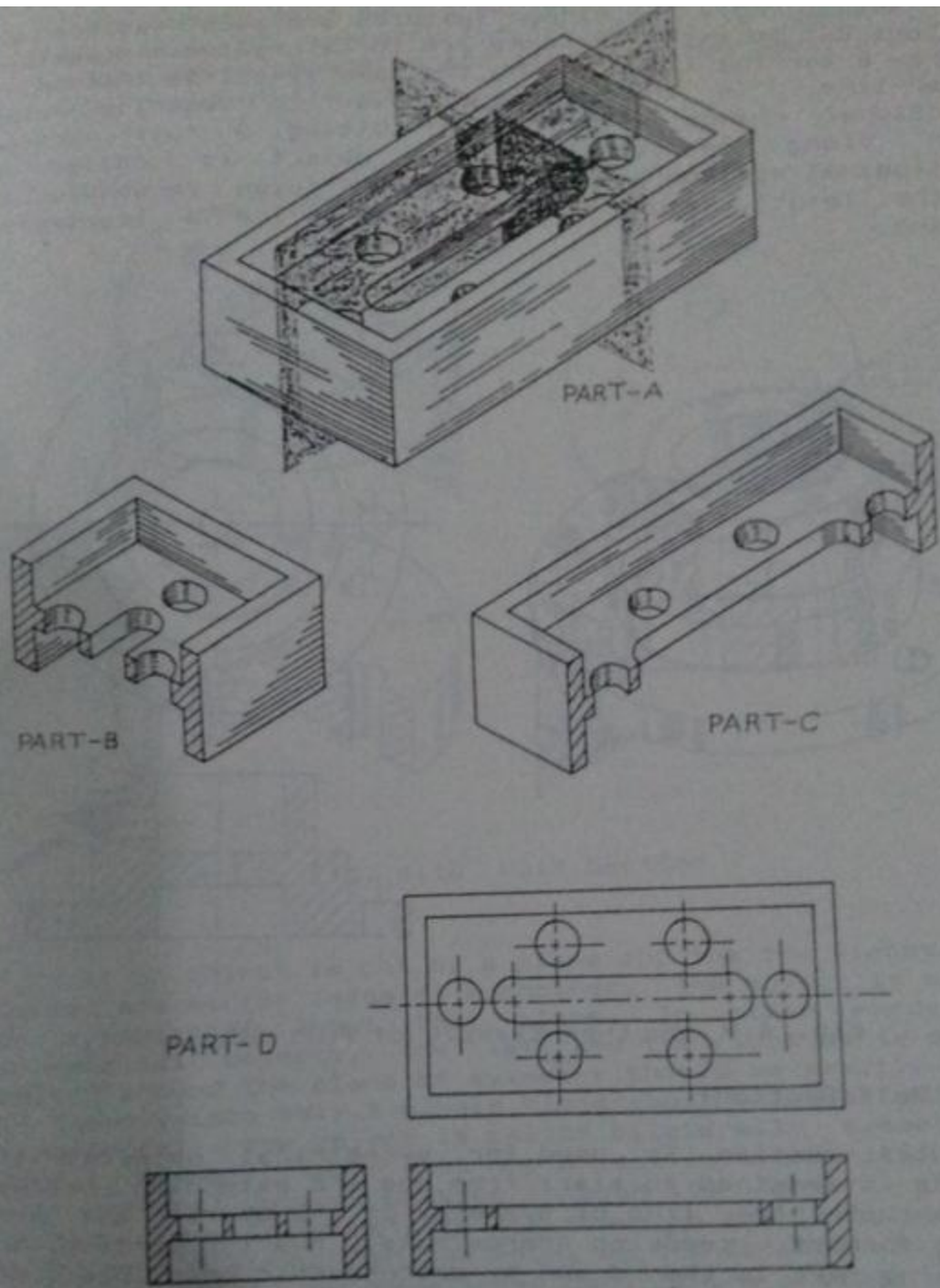

Fig. 4.8 Full Sections Corresponding to Two Cutting Planes

That means, only the hidden features are made visible by sections but no extra features are to be created. Sometimes we draw a turning line, having the same symbol as that of a center-line, in the sectional view to describe this directional change in the path of cutting. A full section taken along the length of the object is called a longitudinal section and a full section taken perpendicular to the length, along the width, is called a transverse section.

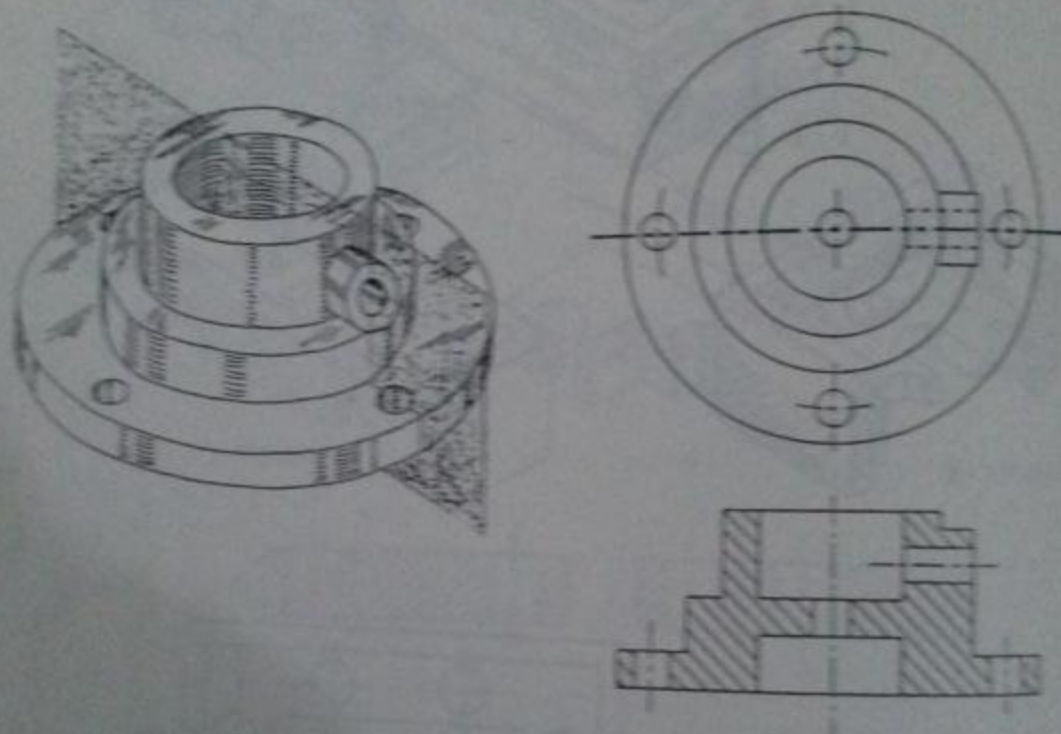

Fig. 4.9 Another Example of Full Section

4.2.2 Half Section:

Half section is used for symmetrical objects, the cutting is imagined to start from one end extending halfway across upto the line of symmetry of the object and then coming forward, removing approximately quarter portion, the remaining part is then drawn by orthographic principles. In case of half section, one half of the view is drawn in section and the other half as a regular exterior view. A half section has the advantage of showing both the interior and exterior of the object on a single view. Change in plane-direction for the offset of the cutting plane is not

shown because no edge exists on the object at the center. However, axis of symmetry for the object is shown by a center line which separates the simple orthographic and the sectional parts of the view.

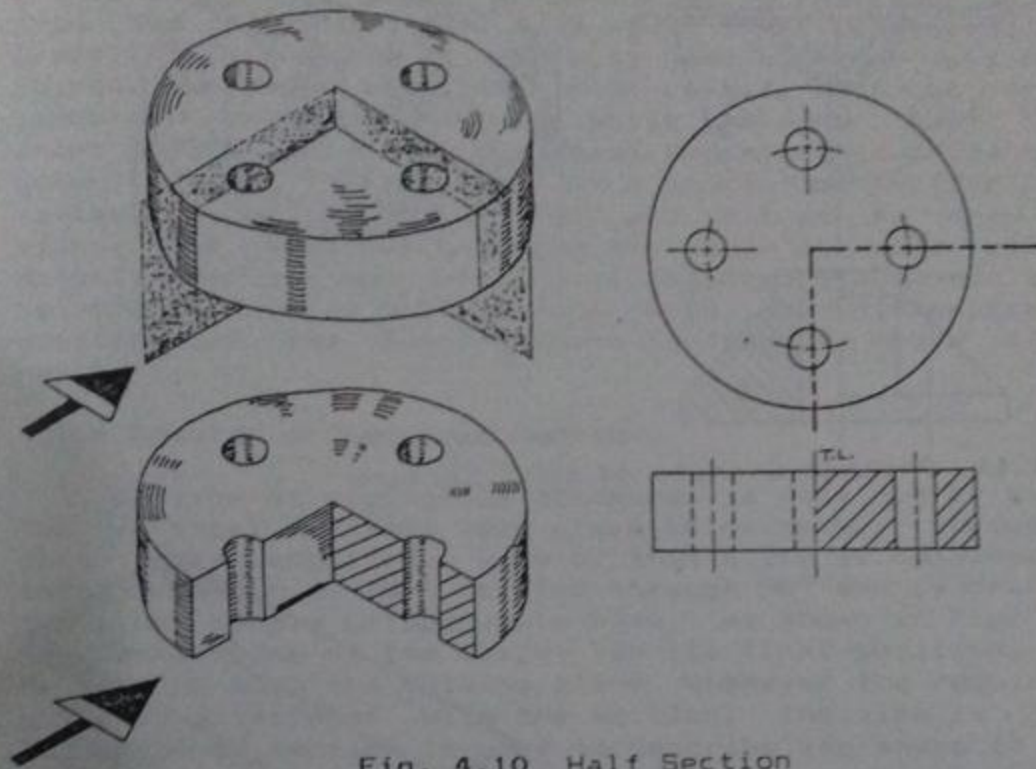

Fig. 4.10 Half Section

If an object is cut by a plane and the two pieces thus formed are mirror image of each other, the object is said to be symmetrical about that plane. In other words, for symmetrical objects, the left and the right parts of the object around the plane of symmetry should be exactly alike. If there exists only a single plane about which an object is symmetrical, the object is called bilaterally symmetrical. Radial symmetry means that the object is symmetrical about all vertical planes passing through its center. In half section, say inner details are shown in the left sectional part of the view, then, we know, by the definition of the symmetry, that the same inner details are present on the right side of the object. Similarly, the exterior of the object shown in the right side of the view will be the same as that for the left side. Hence only one view will describe the outer as well as the inner details of the object.

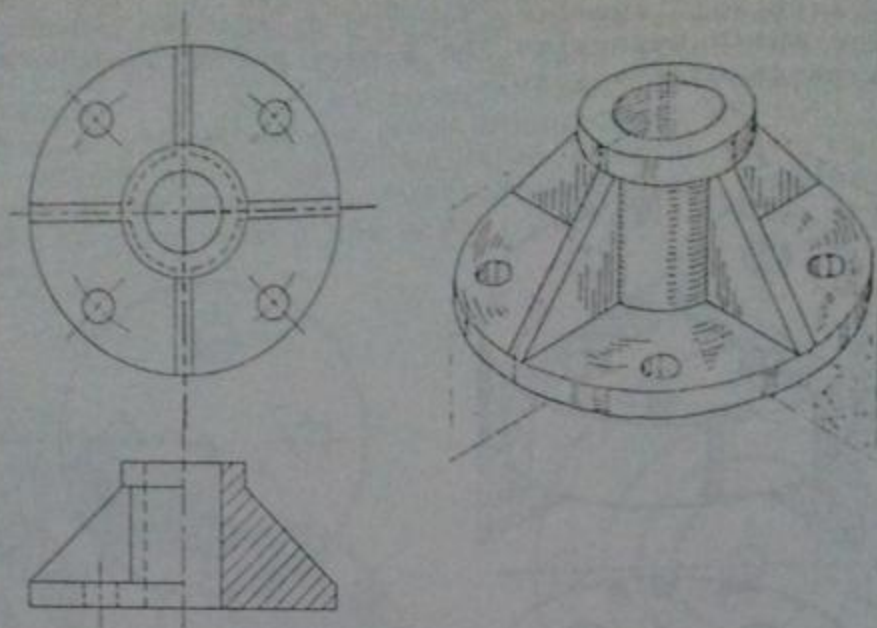

Fig. 4.11 Another Example of Half Section

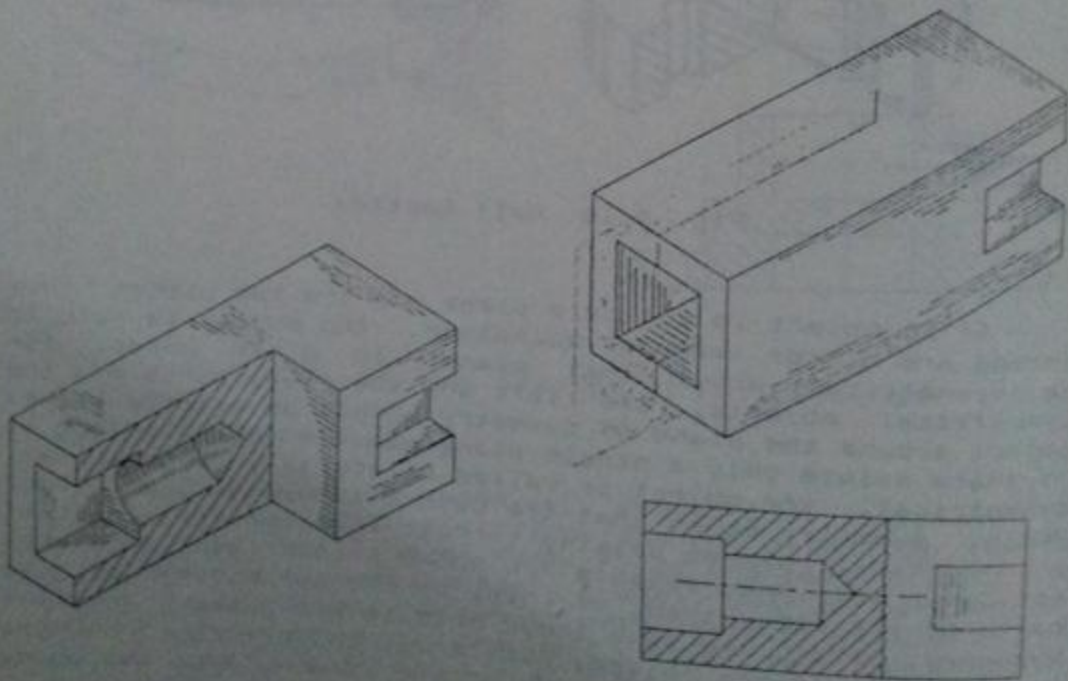

Fig. 4.12 Broken-Out Section

4.2.3 Broken-Out Section:

In case of a broken-out section, the cutting starts from one end, the cutting plane is extended inside the object only so far as needed, and the outer part of the object is then thought of as broken-off. The resulting orthographic view will partially be in section separated from the exterior view by a wavy line representing the break. This section is generally used when one part of the object has more important inner details with no or less important exterior features while the other part has no inner construction but possesses important features on the outer surface. The advantage of a broken-out section is the saving in space on the sheet and in time to draw extra views, one view may describe the outer as well as inner details even for non-symmetrical objects. Broken-out section is similar to a half section with the difference that position of the cutting plane is fixed in case of half section.

4.2.4 Rotated or Revolved Section:

A slice of negligible thickness is obtained by assuming two vertical cuttings very close to each other through the part to be described, view of this slice is obtained as a section which is then rotated through 90° and is drawn onto the other simple orthographic view, as shown in Fig. 4.13. The center-line of the slice, in its final position, should be in line with the cutting plane. Whenever the regular view outline interferes with the section, the view is broken. This type of section is used to describe the shape of small parts that would otherwise be difficult to show and the main advantage is that extra complicated views may be avoided. When this type of section makes the simple orthographic view unreadable, it should not be used, removed section is preferable in such cases.

4.2.5 Removed Section:

In case of a removed section, a slice of negligible thickness is considered from inside the object and instead of drawing its shape on any regular orthographic view, it is removed to some adjacent place and is separately drawn there. The cutting plane should always be indicated with reference letters in case of a removed section to identify the section whenever needed. The main advantage as compared with a rotated section is that the regular views are not disturbed and a number of different sections may be drawn for an object. Further, details behind the cutting plane are eliminated in both rotated and removed sections, making

these views much simpler.

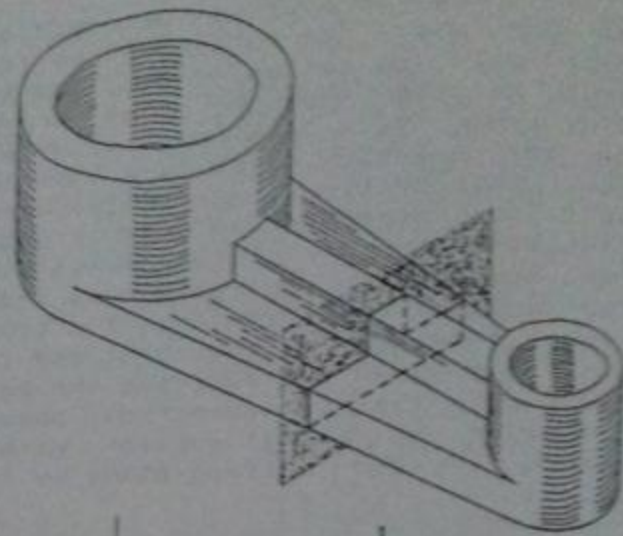
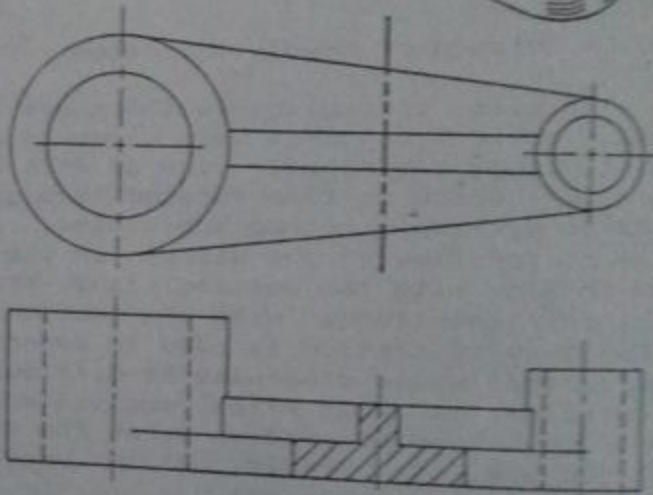

Fig. 4.13
Rotated Section



4.2.6 Assembly Section:

Assembly drawings are used to assemble various parts to make a machine and the purpose of an assembly section is to reveal the interior of a machine or structure so that the relative position of the separate parts can be clearly shown. In case of assembly sections, separate parts are not described completely because their detailed drawings are separately prepared.

4.2.7 Auxiliary Section:

For an important part of the object inclined to the principal planes of projection, an inclined cutting plane

may be considered to pass through it, and then normal view

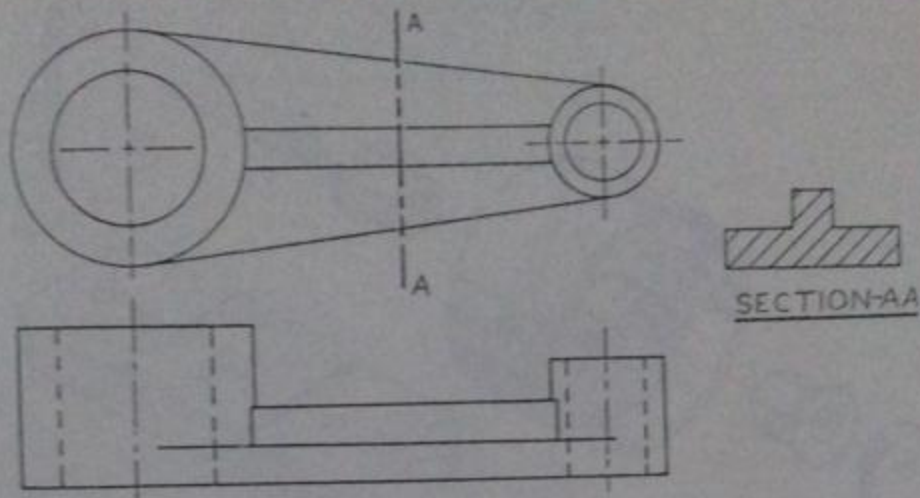

Fig. 4.14 Removed Section

of that part may be drawn on a picture plane parallel to the cutting known as auxiliary section. This type of section is needed to indicate the actual dimensions of the inclined part.

4.3 DETAILS BEHIND THE CUTTING PLANE:

All the details behind the cutting plane visible after the cutting must be drawn as simple orthographic view. Fig. 4.17 shows an object pictorially with front part removed thus exposing the inner details. A sectional front view of the cut surface without the visible features, as shown in the figure, should never be used. Correct sectional view is that which is showing all the visible edges and surfaces behind the cutting plane in addition to the cut-surface. However, edges and surfaces which remain hidden even after the cutting are not shown with the help of dashed lines in part of the view which is in section. Usually dashed lines in a sectional view complicate the view, as shown in Fig. 4.18, and donot add any information; the view without these becomes simple, less time-consuming to draw, and more easily readable, as shown in the same figure.

4.4 PARTS NOT SECTIONED:

Many machine elements have no internal construction and are more easily recognized by their exterior views, such as fasteners, pins, and shafts. Features of this kind are not

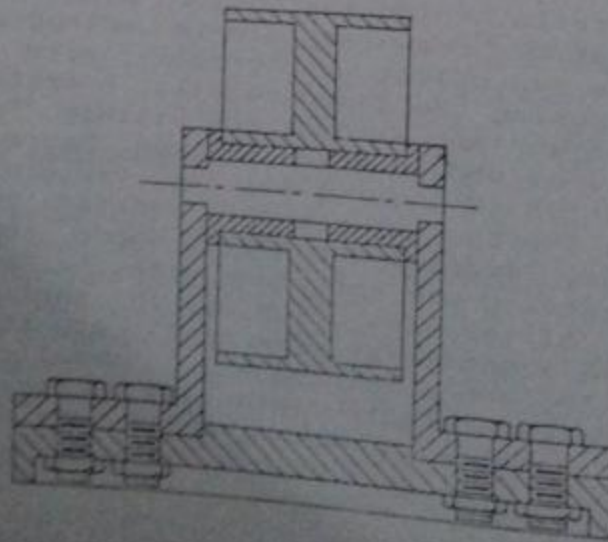
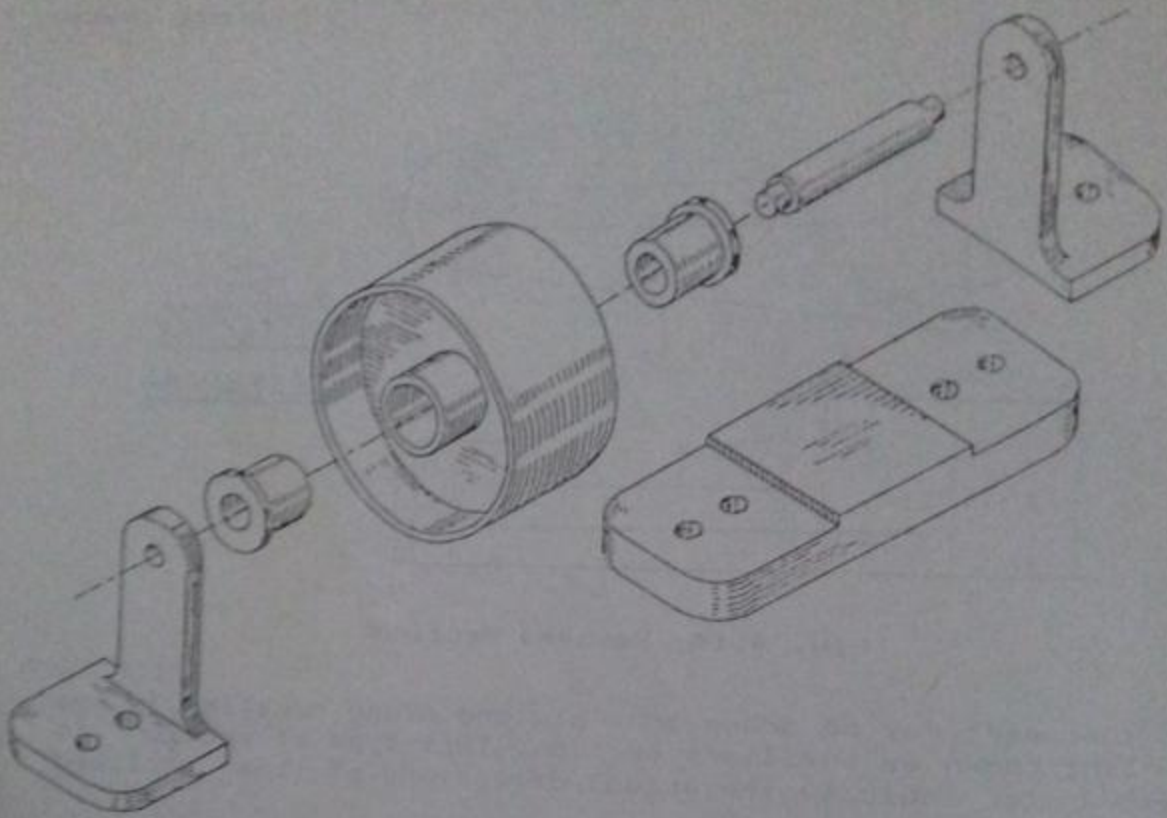

Fig. 4.15 Assembly Section

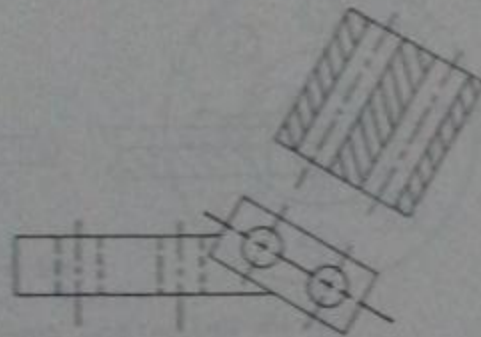
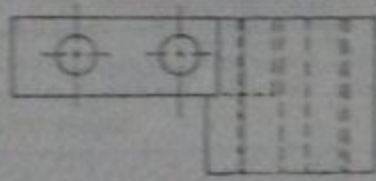

Fig. 4.16 Auxiliary Section

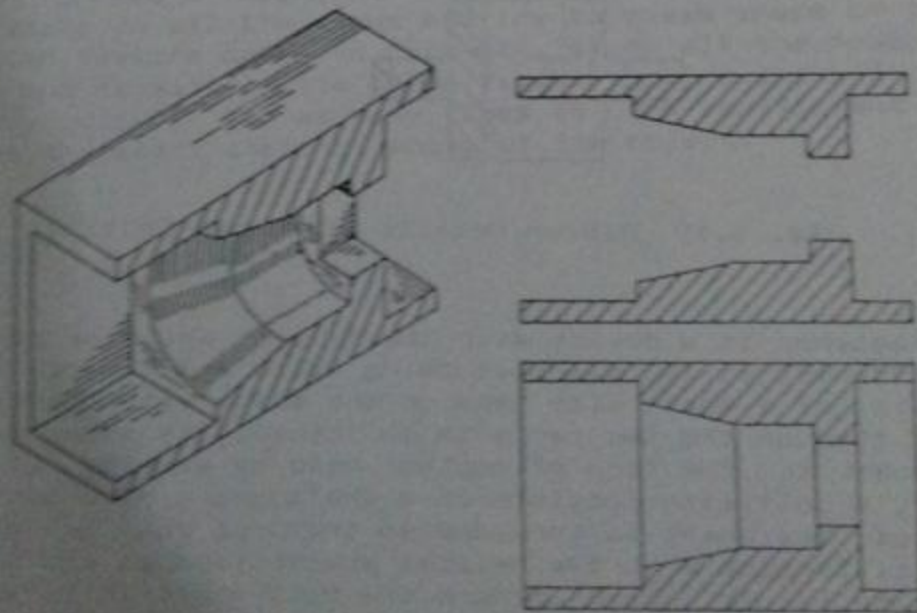

Fig. 4.17 Visible Details After the Cutting

assumed to be sectioned even if the cutting plane passes through them and their exterior views are always shown. If these parts are sectioned and cross-hatched, they become more difficult to be read because their typical identifying features like bolt heads, rivet heads, chamfers on shafts, etc., are removed.

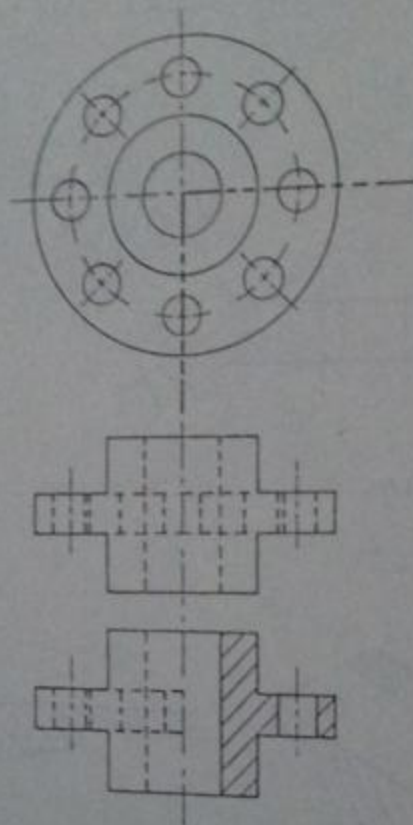

Fig. 4.18 Hidden Details After the Cutting

Fastener is a device with the help of which we can tie two different parts, examples being bolts and rivets. Rivet consists of a shaft with head on one side. After passing a rivet through the two parts to be joined, its other end is flattened in the form of another head by working it with hammer. A bolt also consists of a shaft and a head but end of the shaft is threaded so that nut can be screwed over it. Threads mean the helical projections on the surface of the bolts. Bolt-head anchors the bolt while it is screwed from the other end by the nut. In section the bolt appears just as a solid rod without any internal construction whereas exterior view gives more details about it.

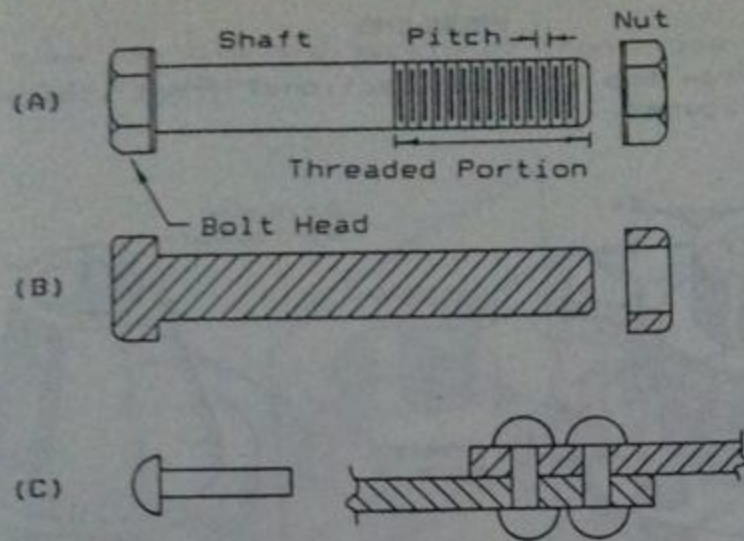

Fig. 4.19

- (A) Exterior View of Bolt
- (B) Sectional View of Bolt
- (C) Separate Rivet and Installed Rivet

4.5 READING ORTHOGRAPHIC VIEWS:

If a try is made to conceive the three-dimensional shape of any object from its orthographic views in one step considering all the features together, it is impossible to do so. To read orthographic views, look for lines showing some feature in all the views and try to guess shape of that particular feature only. In this way, study all the features one by one consulting the three views. Now revise all the features quickly for as many times as are sufficient to conceive the exact shape of whole of the object.

PROBLEMS

4.1 AND 4.2 Draw top view and sectional front view for each of the given figures.

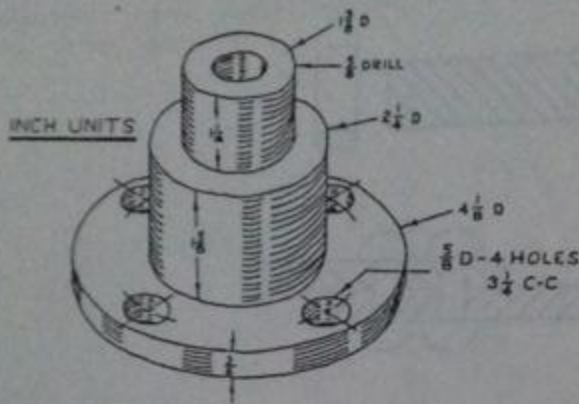

Prob. 4.1

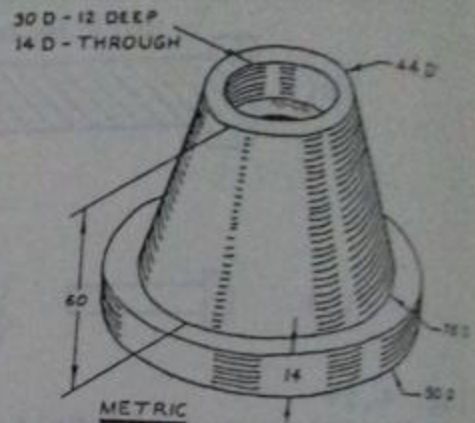

Prob. 4.2

4.3 Draw views to best describe the external and internal shape of the given figure.

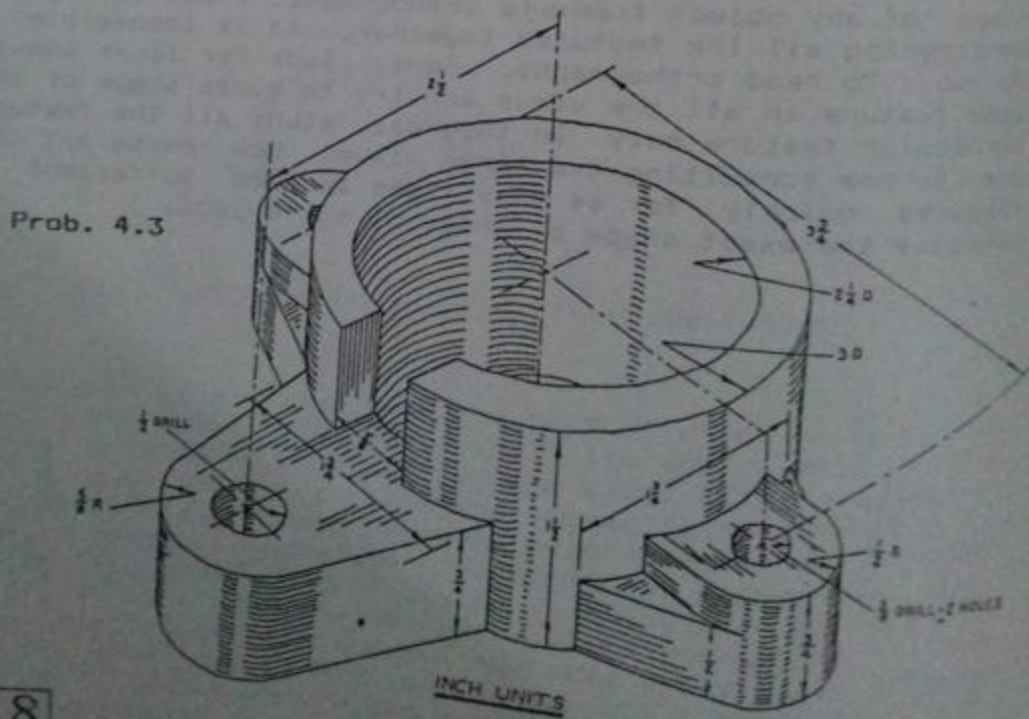

4.4 Draw top view and sectional front view according to the cutting plane shown.

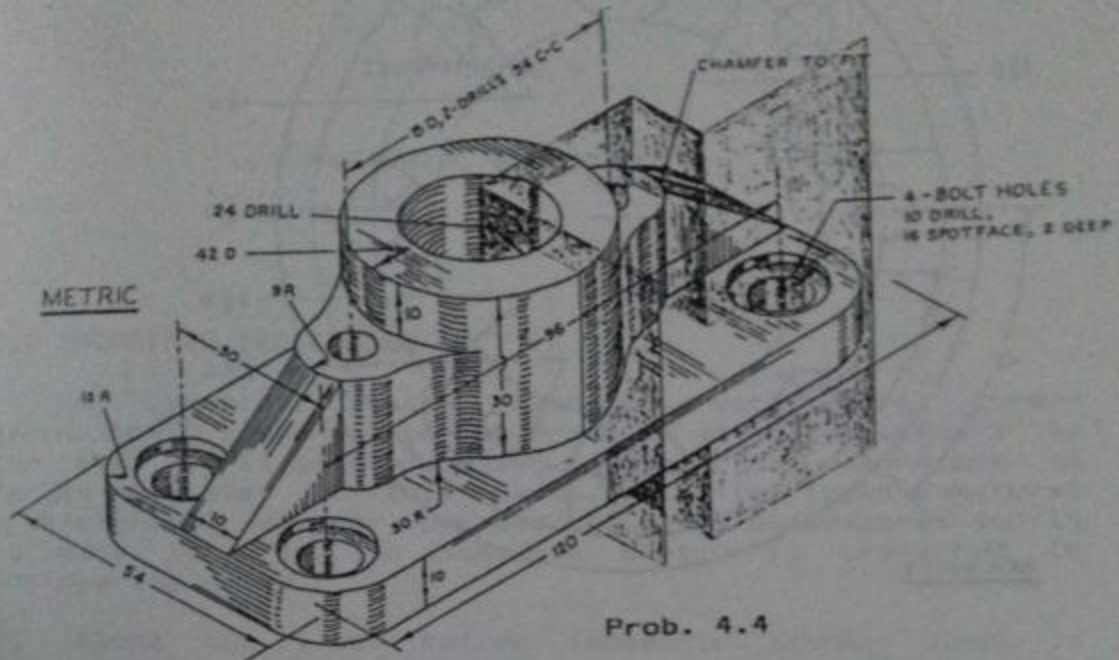

4.5 and 4.6 Read the two orthographic views provided for each of the problem to conceive the true shape of the object. Repeat the top views and draw the front views as sectional views of suitable types.

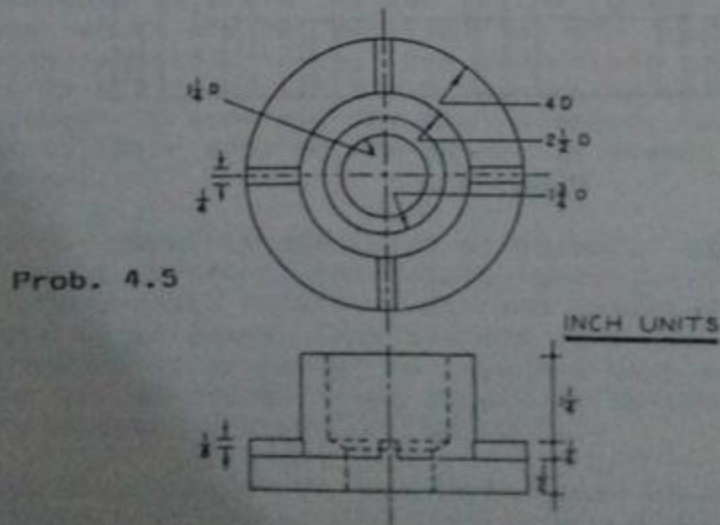

CHAPTER NO.5

PICTORIAL SKETCHING

5.1 ISOMETRIC SKETCHING:

An isometric sketch, although a pictorial or three-dimensional drawing, is not drawn as an object appears to the eye. It is made according to the actual dimensions as far as possible. For this reason, it often looks unnatural or distorted. However, because it can be dimensioned and it is easy to draw, an isometric sketch is preferred in engineering works.

Along the lines called isometric lines, shown in Fig. 5.1, the dimensions vary in a fixed proportion, the isometric lengths are 0.814 of the true lengths. If instead of shortened isometric lengths, the true lengths are adopted, the view obtained will be exactly of the same shape but larger in proportion. Due to the convenience in construction and the advantage of measuring the dimensions directly from the drawing, it has become a general practice to use the natural scale instead of the isometric scale. For the lines which are not parallel to the isometric axes, called non-isometric lines, the dimensions are not reduced according to any fixed ratio. Measurements should always be made on isometric axes and the non-isometric lines are drawn by locating their ends on the isometric planes and then by joining them.

To draw isometric sketch of an object, assume it to be enclosed in an isometric box having length, width and height equal to the overall length, width and height dimensions of the object to be drawn. Coincide one vertical edge of this box with the vertical isometric axis and show the horizontal edges on the 30-degree lines according to the length and width dimensions, as shown in Fig. 5.2.

After construction of the rectangular box, the ends of the non-isometric lines are located by measuring on the

surface of the box. This method of drawing an isometric view is termed as box method. Offset method should be used for the objects in which ends of the non-isometric lines do not lie in isometric planes. Perpendiculars are dropped from each end of the non-isometric lines to any of the isometric planes. The points at which the perpendiculars meet the planes are located on the sketch and from there the required offsets are drawn.

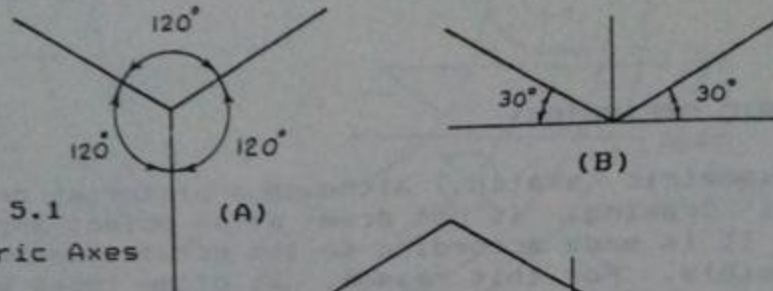

Fig. 5.1
Isometric Axes

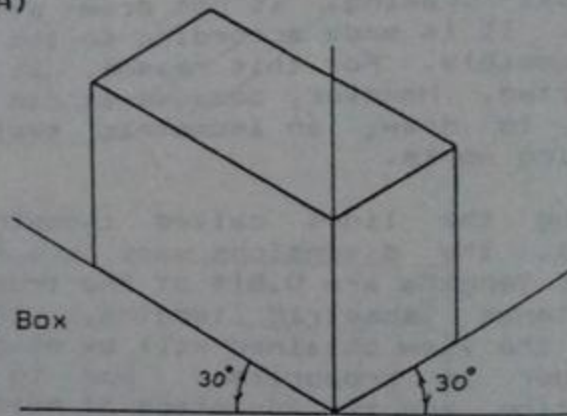

Fig. 5.2 Isometric Box

5.1.1 To Sketch an Ellipse Representing a Circle:

A circle may be drawn in isometric projection by enclosing it in a square. An isometric plane is drawn to represent the square, the mid-points of the sides of the square are joined together to give the center-lines of the circle. These four points, 1, 3, 5 and 7, represent the points of the circle at 90° angle, as shown in Fig. 5.3.

Four more points showing intersection of the diagonals with the circle may be obtained by the offset method. To plot point '6' in the isometric sketch, its projection on line 'ad' may be drawn locating point 'x' in A-part of the figure. On line DA in B-part of the figure, the equivalent point 'X' may be located by measuring the distance equal to 'dx'. An offset may now be drawn parallel to the line DC having a length equal to x6, point-6 is thus located. A

smooth curve drawn through all points, numbered from 1 to 8, will be the isometric projection of the circle which will actually be an ellipse. Isometric paper, as shown in Fig. 5.4, may also be used to draw isometric sketches very quickly.

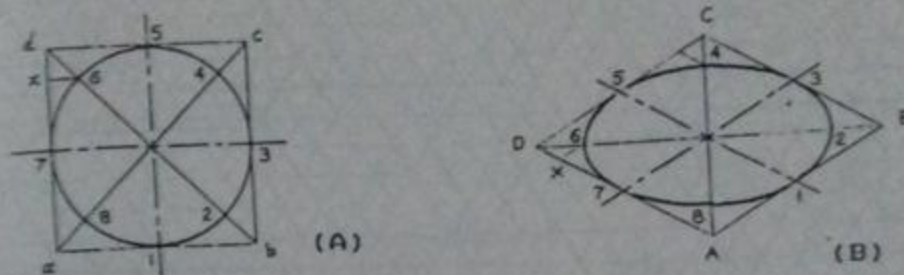

Fig. 5.3 Circle in Isometric View

5.1.2 Example of Isometric Sketch From Orthographic Views:

The three orthographic views are given for an object in Fig. 5.5 (A) and its isometric sketch is to be drawn on an isometric paper. Draw rectangular box on the isometric paper according to the total length, width and height of the object. Length dimensions for all the parts are to be taken from the front and the top views of the object, width dimensions from the top and the end views, and height dimensions from the front and the end views which may be transferred to the isometric axes. Draw curve 4 using the procedure discussed in section 5.1.1, curve 1-3-2 may now easily be drawn seeing the shape of the inner curve. Similarly draw curve 5-7 according to the procedure and curve 6-8 by looking at the shape of the curve 5-7. Locate all other points and properly join to get the isometric view.

5.2 PERSPECTIVE SKETCHING:

A pictorial or perspective projection is a method of producing a two-dimensional view of a three-dimensional object that shows the height, width, and depth simultaneously. Perspective sketching is the representation of an object as it would appear to the eye when viewed from a definite position from the object. Camera photograph of an object is also an example of perspective view of the object. Projection-lines, in this case, are neither parallel to each other nor perpendicular to the picture plane, thus, the actual dimensions are not shown here. With the help of

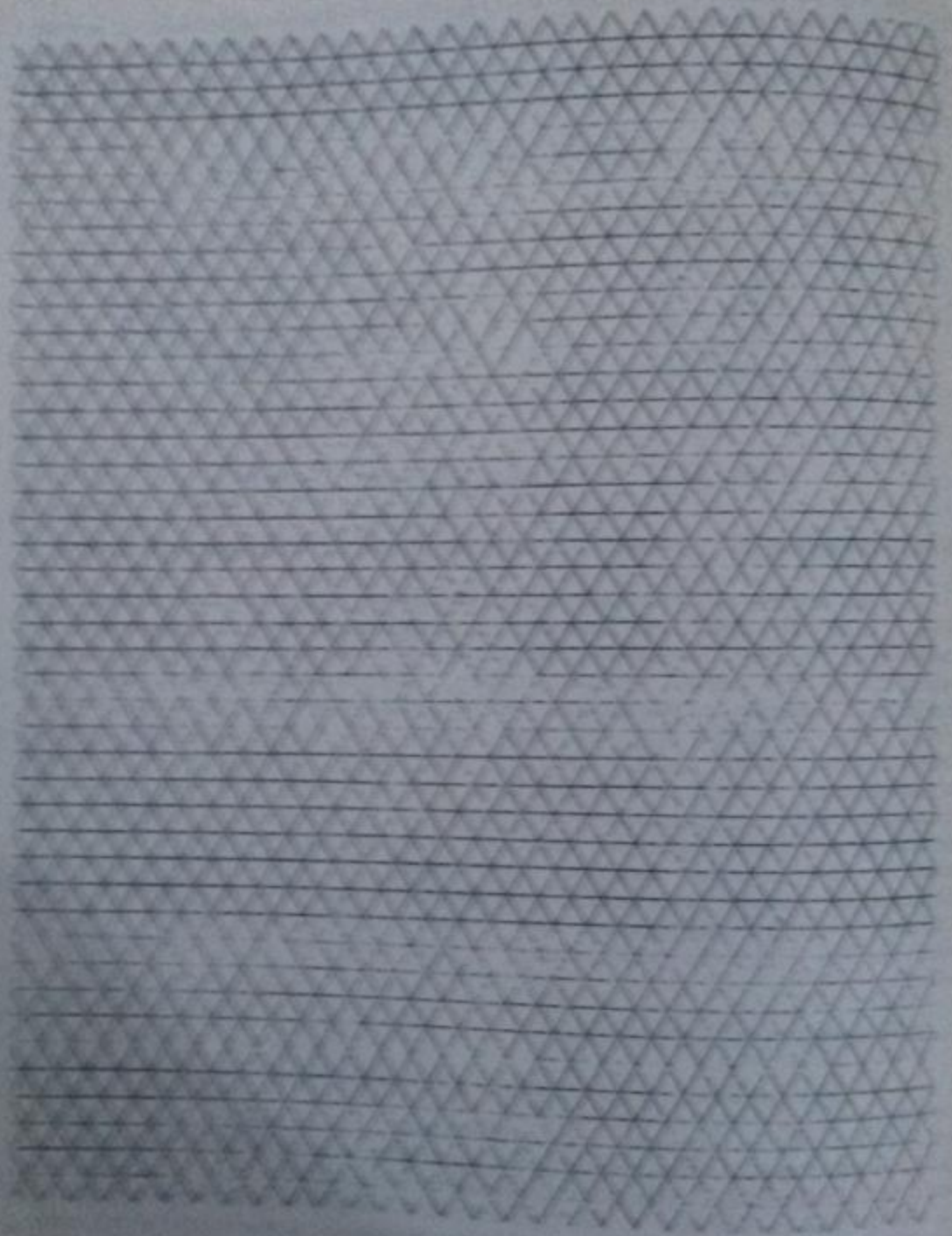

Fig. 3.4 Isometric Paper

perspective view, an architect can exhibit as to how an object would look like after construction.

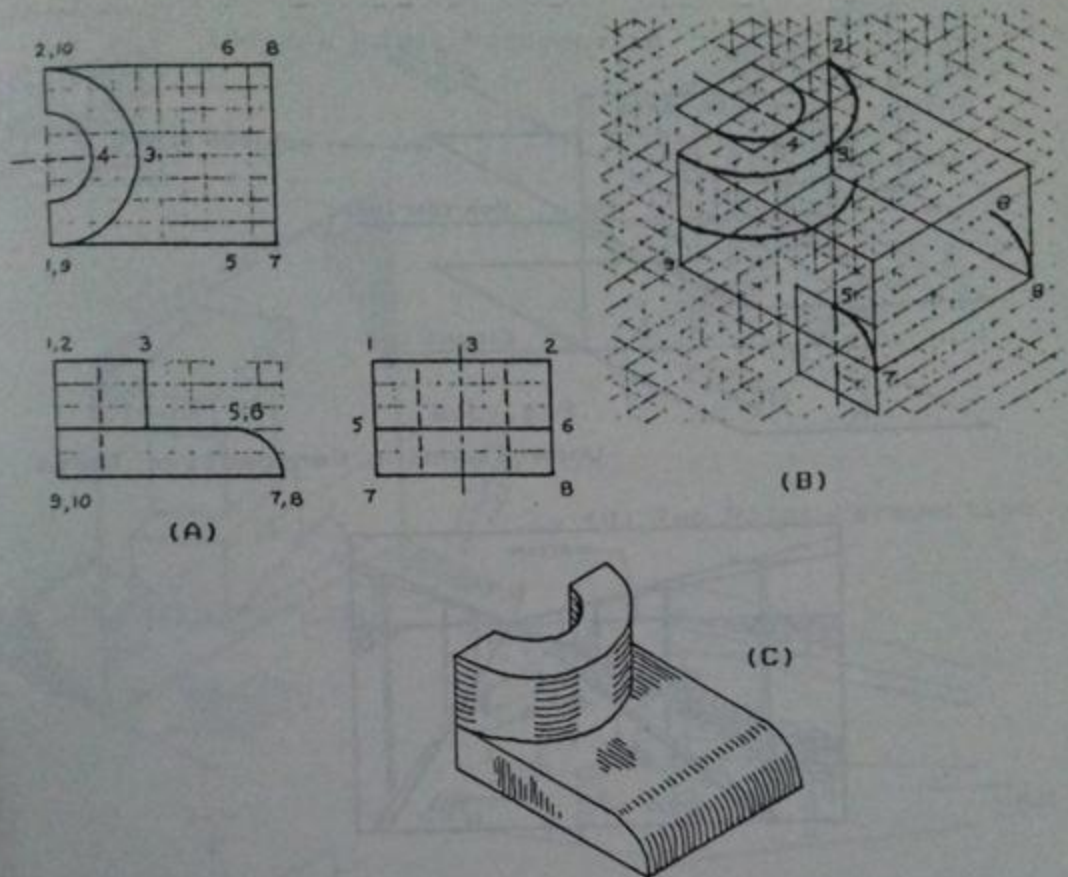

Fig. 5.5 Construction of an Isometric View

Figure 5.6 illustrates most of the basic definitions from perspective projection. A suitably selected point at comparable distance from the object to view the same is called station point (SP), the eye of the observer may be considered at the same point. A horizontal plane passing through the station point is called horizon plane. Ground plane is the plane over which the object is placed and it is always horizontal. Axis of vision is a line passing through the station point and running perpendicular to the picture plane. Picture plane (PP) is a vertical plane placed in-between the object and the observer over which the view is formed, it should be perpendicular to the axis of vision. Intersection of the picture plane with the horizon plane and

the ground plane defines horizon line and ground line respectively. The intersecting point of axis of vision with the picture plane is called the center of vision.

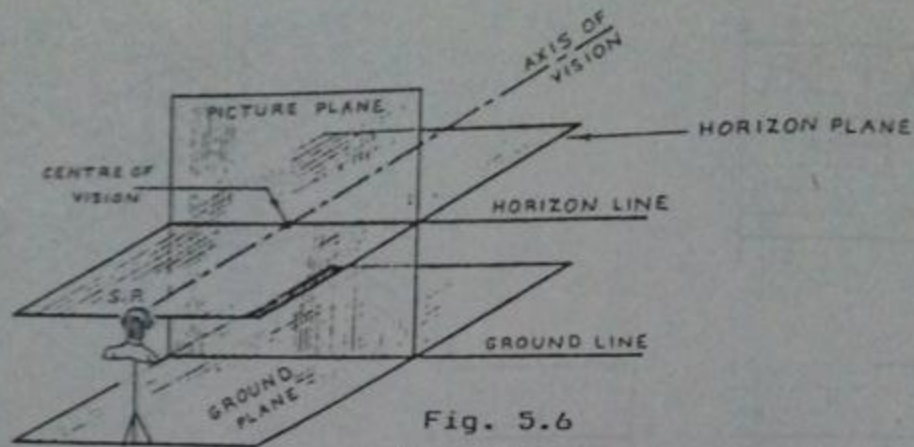

Fig. 5.6

Understanding Perspective Terms

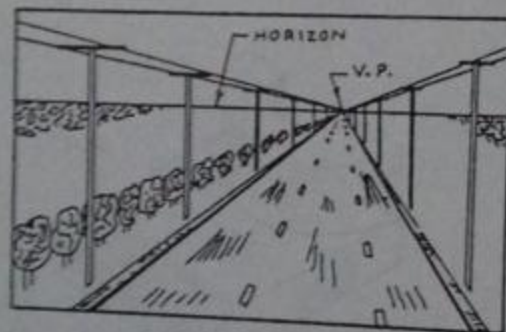

Fig. 5.7 Concept of Vanishing Point

Objects at a distance appear to be relatively smaller than those which are near. Two parallel lines representing the edges of a straight road seem to come closer together and then meet at a point on the horizon, called the vanishing point (VP). Even the electric wires running along the road appear to meet at the same point. Perspective projection involves a number of projectors converging at one, two, or more vanishing points, representing the objects as they would appear when viewed from a particular point in real life.

In case of one-point perspective, front face of the object is kept parallel to the picture plane. The two dimensions (length and height) appear nearly in the same



(A) One Point Perspective

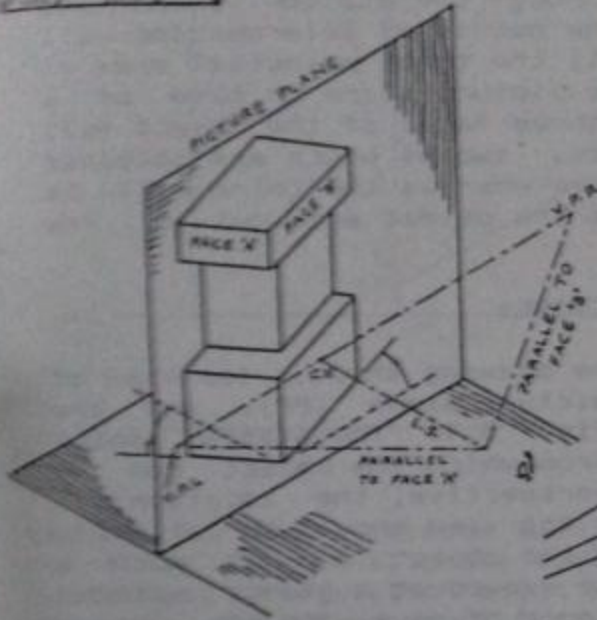
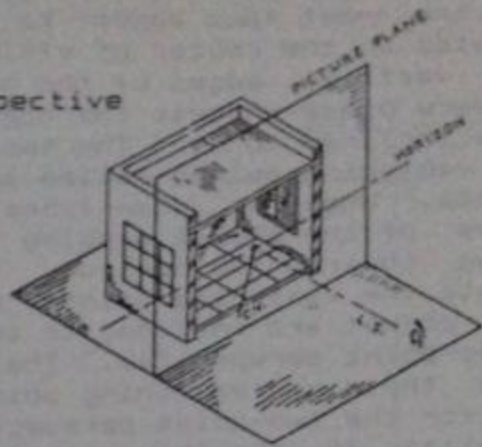

(B) Two Point Perspective

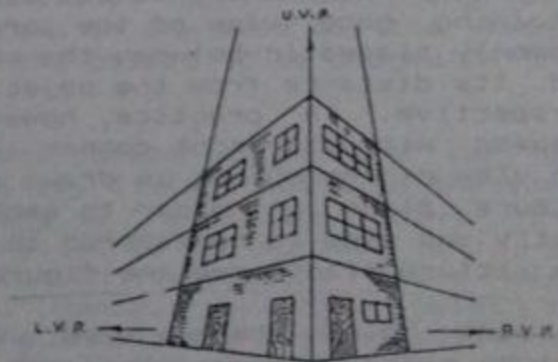
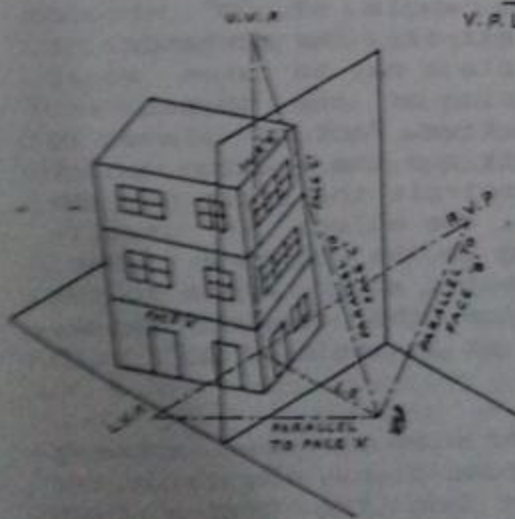
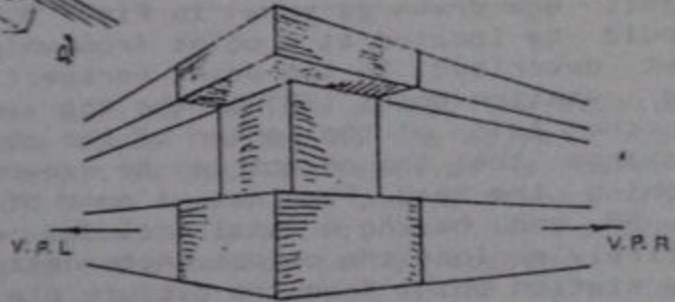

(C) Three Point Perspective

Fig. 3.8 Types of Perspectives

proportion, whereas, the edges of the object perpendicular to the front face appear to converge at a vanishing point located on the center of vision. For two-point perspective, the vertical edges of the object are made parallel to the picture plane whereas the horizontal axes of the object are made inclined to it. The two vertical faces will have their own vanishing points called the left and the right vanishing points. When we draw lines parallel to the two principal faces of the object passing through the station point and going towards the horizon, the points of intersection will locate the vanishing points. All the three principal axes of the object are inclined to the picture plane in case of a three-point perspective. The three faces of the object will have their own vanishing points, two of which are obtained as for the two-point perspective whereas the third will be parallel to the third face of the object and out of the horizon line.

• 5.3 TO DRAW A TWO-POINT PERSPECTIVE:

1. In the upper portion of the drawing sheet, top view of the station point (SP), the picture plane (PP), and the object are drawn as shown in Fig. 5.9. The station point should be located at a point from which the object can be best described. In two-point perspective, the location of the station point (SP) in the top view should be slightly to the left of the center of the object and at such a distance that the object can be viewed at a glance without turning the head. For that, a cone of rays with its vertex at SP and having a total included angle of 30° should entirely enclose the object. Alternatively, the distance of the station point from the picture plane may be taken equal to about twice the greatest dimension of the object for obtaining good view of the perspective. Picture plane is commonly placed in-between the object and the station point and its distance from the object controls the scale of the perspective. In practice, however, the object is usually assumed with its front corner lying in the picture plane. Top view of the object is drawn oriented at any angle to the picture plane in order to emphasize the desired shape, mostly one side is considered to be at an angle of 30° with the picture plane, see the figure.

2. Just below the top view, front view is drawn showing picture plane, horizon plane and ground plane, the latter two being represented by the horizon and the ground line respectively, whereas, the picture plane coincides with the plane of the paper and the perspective is drawn on it. The horizon is drawn at a distance above the ground line representing the altitude of the station point above the

vanishing point (VL) can also be located in the top view and the front view.

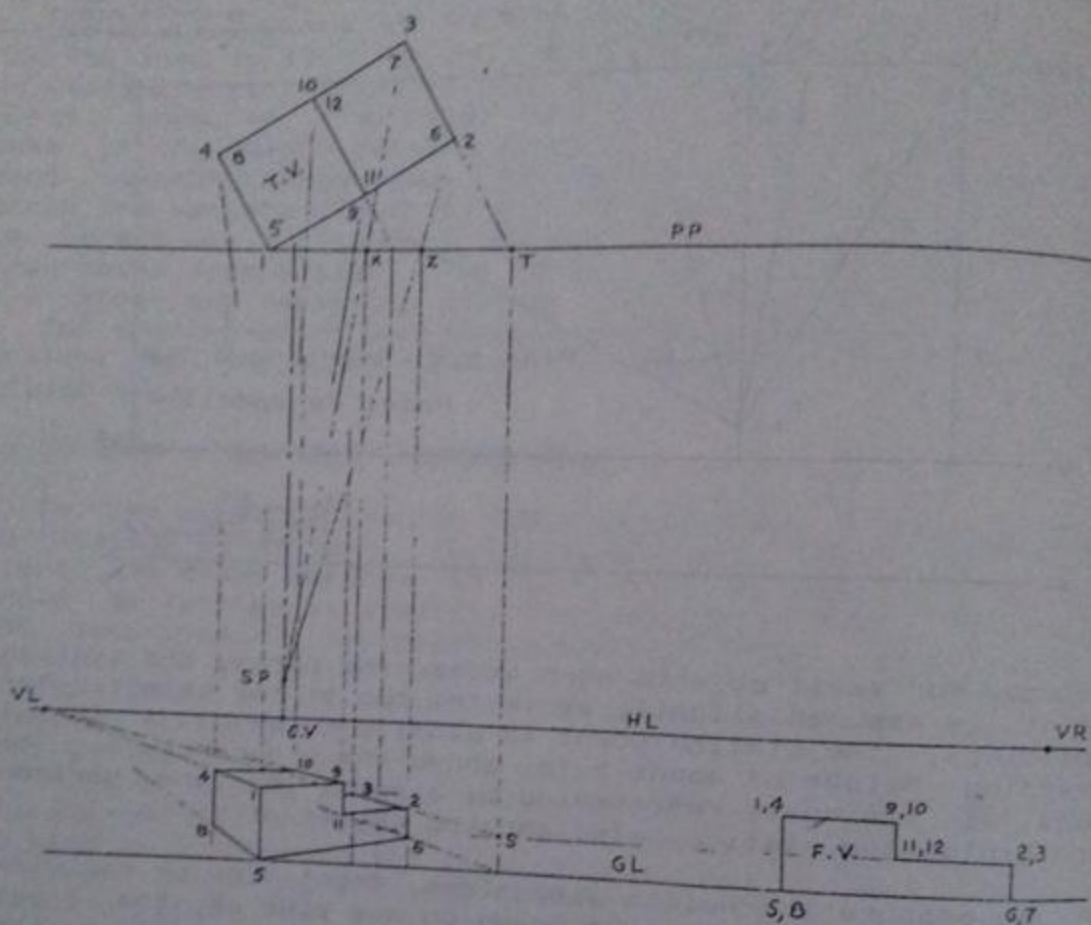

Fig. 5.10 Completing the Perspective of Fig. 5.9

5. To locate any point on the perspective, its horizontal position and its height from the ground should be known. A point is located in the perspective horizontally by drawing a visual ray from SP to that point in the top view and projecting down the piercing point of this ray with the picture plane to the plane of the perspective in the F.V. For example, in Fig. 5.10, visual rays are drawn from SP to the points 3 and 2 on the object in the top view, the piercing points on the picture plane being X and Z. These piercing points are then projected to the frontal view locating the required points on the perspective if their height is also known as discussed in paragraphs 6 and 7.

6. All heights behind the picture plane are foreshortened in the perspective and only those lying in the picture plane will appear in their true length. For this reason, all measurements must be made in the picture plane. The point, whose height is to be found out, is brought forward to the picture plane along some established line in the top view. A vertical line is then drawn upto the ground line which is called a measuring line, the true height can be measured over it. The point obtained according to the actual height is then joined with the vanishing point to get the height at any distance behind the picture plane. For example, to find out heights of points 3 and 2 in the perspective, line 3-2 is extended in the top view until it pierces PP at the point 'T'. The point T is then projected downward, the line TS being the measuring line for all the vertical dimensions of the face 2-3-6-7. The heights of points 3 and 2 are now measured directly starting from the ground line or are transferred from the elevation to obtain point 'S'. The line S-VL is the perspective of a line of infinite length containing the perspective of the line 3-2 and it can give the height of any point on the line 3-2 in the perspective.

7. The intersection of the lines obtained in the paragraphs 5 and 6, showing horizontal position and height, locates the point in the perspective. For example, in Fig. 5.10, the intersection of the line S-VL with the position lines of the points 3 and 2 will locate the points.

8. All the points can be located in the same way and the perspective can be completed. The perspective may be drawn by using a single vanishing point, however, the other vanishing point provides a check for the accuracy of the construction.

PROBLEMS

Draw isometric views for problems 5.1 to 5.4 and two-point perspective views for the first two problems.

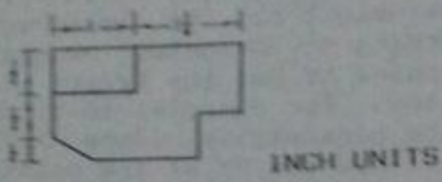

INCH UNITS

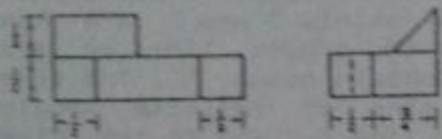
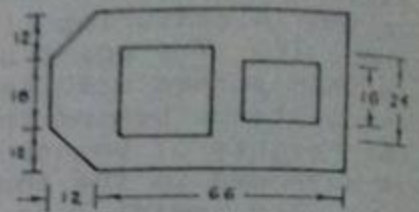

Prob. 5.1

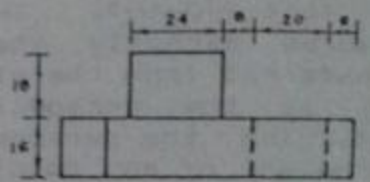

Prob. 5.2

METRIC

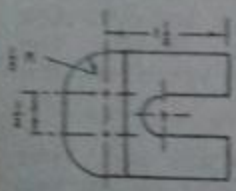

Prob. 5.3

INCH UNITS

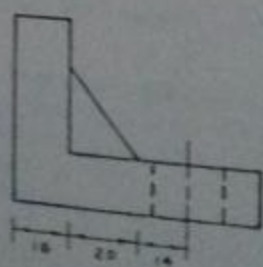
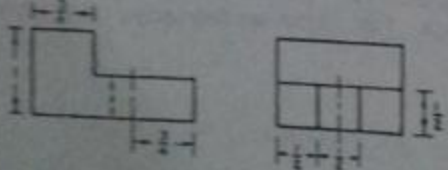
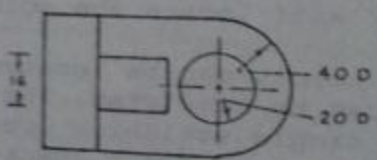

Prob. 5.4

METRIC

CHAPTER NO.6

BUILDING DRAWING

6.1 BASIC DEFINITIONS

6.1.1 Concrete:

Concrete is a mixture of stone particles and some suitable binding material. While in fresh state, concrete is plastic or fluid-like and may be molded in any shape but, with time, it hardens and becomes an artificial stone-like material. Because small stone particles may be "assembled" at site to provide any desired architectural shape and because of the relatively lesser cost, concrete is used for most of the construction. The main constituents of concrete are described below:

(A) Binding Materials: It is usually a paste of cement in water and is the relatively costly constituent of the concrete. Lime and some other materials may also be used as binding material.

(B) Filler Materials: It is required to reduce the cost and, at the same time, to provide sufficient strength. Most commonly filler material is composed of natural round gravel or crushed stone but other materials like brick-ballast, bloated clay and iron chips may also be used in certain cases. Filler material may also be termed as "Aggregate".

Within a particular aggregate, particles of all the sizes must be present in a suitable proportion. In other words, the size of aggregate particles should gradually reduce to minimum so that the smaller particles may fill spaces between the larger particles to give a dense mass. It is quite clear that the larger particles must be present in greater proportion. Depending upon the particle size, the aggregates may be classified into two categories, Coarse and Fine Aggregates. The portion of aggregate having particle size greater than $3/16$ -in (5 mm) is called Coarse Aggregate while the portion having particle size lesser than or equal

to 3/16-in is called Fine Aggregate (or Sand).

There are two main types of concrete to be used for construction purposes namely Plain Cement Concrete and Reinforced Cement Concrete.

6.1.1.1 Plain Cement Concrete:

It is abbreviated as P.C.C. and is the simple concrete without the provision of embedded steel bars (or reinforcement). It is sufficiently strong in compression (internal force corresponding to push on a body) but is weak in tension (internal force corresponding to pull on a body). Ratio of the constituent materials is also written with a particular P.C.C. to be used in the following standard way:

$$\text{P.C.C.} \left(\begin{array}{ccc} \text{Parts of} & \text{Parts of} & \text{Parts of} \\ \text{Cement} & \text{Sand} & \text{Coarse Agg.} \end{array} \right)$$

For example, P.C.C. (1:2:4) means that cement content by weight is one out of 7 parts, sand is 2 out of 7 parts and coarse aggregate is 4 out of 7 parts.

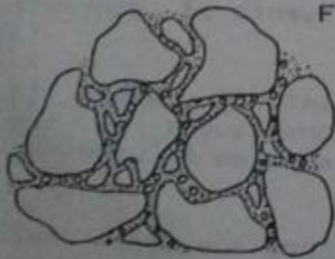

Fig. 6.1 Aggregate Particles in Concrete

a) Lean Concrete: If the cement content in concrete is lesser than about 10%, the concrete is called lean concrete and is commonly used under the floors and foundations. P.C.C. (1:4:8) and P.C.C. (1:6:12) are the examples of lean concrete.

b) Normal Concrete: If the cement content is 10 to 15%, the concrete is called normal concrete, the example being P.C.C.(1:2:4). Normal concrete is used in D.P.C., R.C.C. and floor finishes.

c) Rich Concrete: In rich concrete, the cement content is more than about 15% as in P.C.C. (1:1.5:3). It is used for R.C.C. when smaller structural members are required to support heavier loads for architectural reasons.

6.1.1.2 Reinforced Cement Concrete:

It is abbreviated as R.C.C. and is defined as the concrete with the addition of steel bars or reinforcement to resist tension, as explained in para 6.1.3. R.C.C. is used for beams, lintels, roof-slabs and concrete columns, etc.

6.1.2 Mortar:

Mortar is a material used for plastering of walls and roofs and to join bricks in masonry. Mud mortar and lime mortar were initially used but now-a-days cement sand mortar is most commonly used abbreviated as C/S mortar. Its constituents are cement and sand and the ratio of these materials is also specified. For example, (1:2) C/S mortar means that cement is one part out of three by weight and sand is two parts out of three by weight.

6.1.3 Beam:

Beam is a structural member used to provide support to upper part of the building leaving clear space underneath and to transfer the imposed loads to supports at its ends. Its width is lesser than main dimensions of the building which distinguish it from a roof-slab. Usually the load acts at right angle to the longitudinal axis of the member.

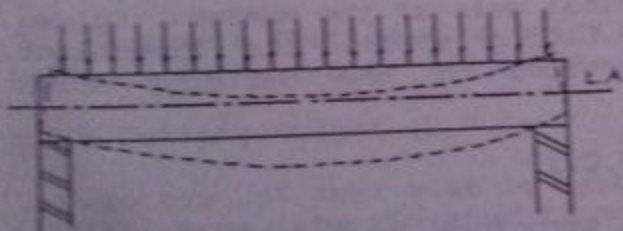

Fig. 6.2 A Typical Beam

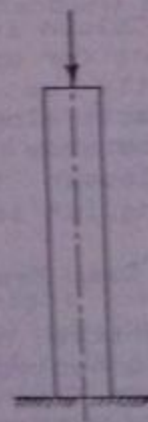

Fig. 6.3 A Typical Column

Main deformation of the beam with the loads is bending. For the beam shown in Fig. 6.2, bending is associated with elongation of the bottom layers and shortening of the top layers. Shortening of the material shows that "push" is acting over it or compression is produced in it. Concrete is

sufficiently strong to develop that much compression. Elongation of the material at the bottom shows that "pull" is acting over it or tension is produced in it. Concrete is very weak in tension and if no reinforcement is provided, the beam will crack at the bottom and will fall down. Another example of material strong in compression and weak in tension is an ordinary piece of chalk. When it is pressed from both ends with the fingers, it is very difficult to break it but very little resistance is offered when it is pulled. Remember that push is a force acting towards the material whereas pull is a force acting away from the material.

If we provide steel bars at the bottom of the beam under consideration, it becomes safe as steel is sufficiently strong in tension. When concrete is provided to resist compression and steel to resist tension, the combination may resist any type of load and is called reinforced cement concrete.

6.1.4 Roof Slab:

The term roof slab is used for the actual load carrying part of the roof present as the lowermost layer.

6.1.5 Column:

Column is structural member which provides a continuous support for upper part of the building and carries the load directly up to the foundations. In case of a column, the load acts along the longitudinal axis of the member. Column may be made up of bricks, R.C.C. or steel. Its dimensions are lesser than main dimensions of the building which distinguish it from a WALL.

6.1.6 Damp Proof Course (D.P.C.):

Bricks have a porous structure and the pores are interconnected to form capillaries. As a result, bricks suck dampness from the soil underneath and pump it to upper parts of the building under the action of capillary force. With dampness mortar and concrete deteriorate reducing the strength of the structure. With time plaster falls down and surface treatments like white-washing and painting are damaged leading to unpleasant appearance. Further these damp conditions are subject to insect and germ growth and are not good from hygienic point of view. A continuous water proof layer is provided above the ground level to prevent the moisture to come up which is called damp proof course or simply DPC. If there is any direct contact between the

underneath soil and brickwork of the super structure, even for a very small part, whole of the building will be affected. DPC to be provided in walls consists of $1\frac{1}{2}$ -in to 3-in thick layer of P.C.C.(1:2:4) over which two coats of hot bitumen are applied. Sometimes, for load bearing walls, polythene sheet is also provided. The top of DPC is made in level with the ground floor top of the building.

6.1.7 Bricks:

It is a structural unit made up of properly burnt clayey soil having the nominal dimensions (including the mortar thickness) as shown in Fig. 6.4.

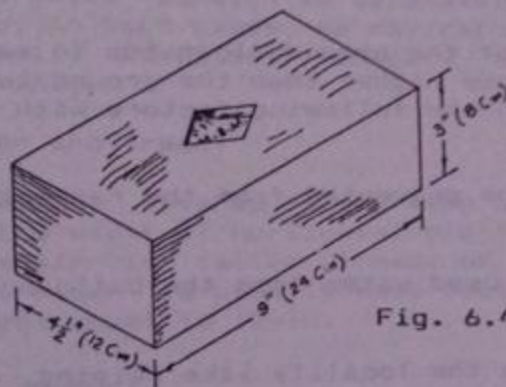

Fig. 6.4 Nominal Dimensions of a Standard Brick

Possible thickness of brick walls is always an integral multiple of $4\frac{1}{2}$ -in or 1/2 brick.

6.1.8 Ceiling Height (C.H.):

Bottom of roof slab is called ceiling. Height of the ceiling from the finished floor level is called ceiling height which normally varies from 8 to 12 ft. In other words, the clear height available inside a building is known as ceiling height. Smaller ceiling height is preferable for multistorey buildings and for buildings where artificial air-conditioning is to be used. Size of air-conditioners or heaters depend upon volume of the building. Bigger ceiling height is preferable for single storey buildings for better natural air-conditioning.

6.1.9 Sill Level (S.L.):

It is the level of bottom of main windows generally

3 ft. higher than the floor level. In the past, a sill or slab was provided at the bottom of the windows projecting from the wall from which the term S.L. is derived. Now a days this type of sill is not used but the term S.L. is still there and is also important for some other definitions.

6.1.10 Finished Floor Level (F.F.L.):

Top level of floor in any part of the building is called finished floor level. It may be different for rooms, verandahs and open areas of a building. Further it is different for different storeys.

6.1.11 Plinth Level (P.L.):

It is the level of the ground floor top in main part of the building. It is made higher than the ground level by an amount depending upon the following factors with a minimum of 1 ft.

- i) The building must be prevented from the rainwater to come inside the building.
- ii) Drainage of the used water from the building must be easy.
- iii) Future trends in the locality like raising of street and road levels is to be kept in mind.

6.1.12 Ground Level (G.L.):

It is the level of ground in or near the building which may be natural or developed ground level.

6.1.13 Super-Structure and Sub-Structure:

The portion of a structure which is visible or which is above the ground level is called super-structure. The portion of the structure present underground is called sub-structure including the foundations and the basements, if present.

6.1.14 Parapet:

Small wall provided on periphery of the roof for safety and privacy purposes is called parapet wall having a height of 1'-0" to about 3'-0" from top of the roof slab. One foot height is only recommended in those buildings where access to the roof is not available and is only used to retain the

filling materials on the roof surface.

6.1.15 Boundary Walls:

It is the outermost wall of a building marking the boundary of the area used to provide safety and privacy inside the building. In undeveloped localities, height of the boundary wall should be higher than eye-level of a common person but should not be so high that it blocks the passage of the wind or the sun. This height is about 5 to 7 ft. from the B.L. In developed areas, according to the by-laws of the controlling authorities, the plot is to be kept open on at least three sides and inside a constructed block is made having its own outer wall with one or two entrances. This constructed portion is separately safe and provides privacy. So, in such cases, we may reduce the height of the boundary wall. Sometimes boundary wall is replaced by plantation only.

6.1.16 Riser and Tread:

The height covered in one step of a stair is called riser and the width of horizontal platform required for one step of stair is called tread or going. For public buildings, riser is usually made equal to 6-in while the tread is kept equal to 12-in.

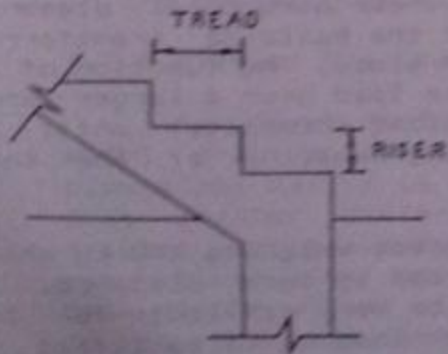

Fig. 6.5 Steps of a Stair

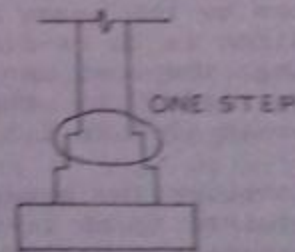

Fig. 6.6 Stepped Wall Foundation

6.1.17 Flight of Stairs:

A series of stair-steps arranged together usually in a single line is called a flight. Maximum number of steps in a single flight must not exceed 12 to 14. Longer flight may be dangerous and uneasy for the person using it. Further it requires a longer space which is generally not available inside a building.

Number of treads in a flight of stair is always one lesser than the number of risers because the top horizontal surface serves the purpose of one tread. Number of steps required for a stair may be found out as follows:

$$\text{Number of risers} = \frac{\text{Height to be covered in inches}}{\text{Riser in inches}}$$

Having decided the values for the riser and the tread, number of risers are then decided using the above relation rounding the answer. The value of riser may then be adjusted accordingly.

6.1.18 Landing in Stairs:

The horizontal platform provided between two flights of a stair is called landing. It enables us to change the direction of stairs so that these may be accommodated in a lengthwise smaller space. Further it provides an opportunity for taking rest during the use of the stair.

6.1.19 Foundation:

The portion of a structure under columns and walls which transfers load of the structure to the soil underneath in a safe way without excessive settlement is called foundation. The load concentration within walls and columns is generally much greater because these structural elements resist the load of greater part of the building transferred to them by the beams and the roof-slabs. The function of a foundation is to re-distribute this load over a larger area reducing the load per unit area (load intensity) until it becomes equal to the safe bearing capacity of the soil underneath (0.5 to 1.5 Tons/SFt).

Consider the example of an object weighing 100 kg which is required to be lifted and carried by some distance. If one labourer is employed, it will be very difficult for him to lift the load. Suppose the same load is to be lifted by employing ten labourers, the work will be completed quite easily. What happens in the second case? Although the total load remains the same, the load per person (called load intensity) is reduced from 100 kg in the first case to 10 kg in the second case.

In case of a stepped foundation, brick wall is expanded below ground level in different steps. The increase in thickness of the wall in one step should be $2\frac{1}{4}$ -in (1/4 brick) on either side with a total of $4\frac{1}{2}$ -in (1/2 brick). The height of each step may vary in multiples of 3-in

depending upon the required depth of foundation from the ground level. At the bottom of each foundation, lean concrete or a compacted mixture of brick-ballast with 25% sand is to be provided; offset of this layer must be lesser than or equal to its depth (6" or 9"). If detailed calculations of the loads is not possible, the number of steps are found out by dividing the wall thickness in inches by 4-1/2".

$$\text{no of steps} = \frac{\text{wall thickness}}{4\frac{1}{2}}$$

Depth of foundation from the G.L. must be sufficient so that the foundation reach to a hard and durable strata with a minimum of 2-ft to take care of the possible erosion by the rain and to avoid the top soil layer having organic matter in it (like roots of trees and grass, etc.) .

6.1.20 Lintel:

Lintel is a small usually concealed beam provided over openings in walls like doors, windows and ventilators.

6.2 COMPARISON BETWEEN MODEL DRAWING AND BUILDING DRAWING:

Although there are minor differences of the conventions used in the model drawing (discussed in the previous chapters) and those in the building drawing, however, concept wise both are the same. Whatever is discussed for simple orthographic views and sectional views will be used in the building drawing as such.

6.2.1 Size of the Object:

The first difference of the building drawing from the model drawing is that now the object will be much bigger, dimensions may be in feet instead of few inches. Because of this greater difference of size of the object with the drawing space available, the dimensions are to be reduced many times for the drawing work. The conversion factor between the actual size and the drawing size, also referred to as reduction factor, is called SCALE. Following set of scales is ordinarily used in the building drawing when working in the imperial units, called architectural scale (refer to para 13 of the article 1.2):

1 , 1/2 , 1/4 , 1/16 , 1/32 , 1/64 ,

Architectural scale is actually an inch-foot scale and one-scale means that one inch of the drawing line represents one foot of the structure, the reduction factor being 12. Half-scale means that 1/2-in of the drawing line represents one foot of the actual structure, the reduction factor being

24. Other scales may also be defined in a similar way. These scales are written on the drawings in the following standard way:

Drawing line size = One foot of the structure

For example,

1-in = 1-ft

1/2-in = 1-ft

1/4-in = 1-ft

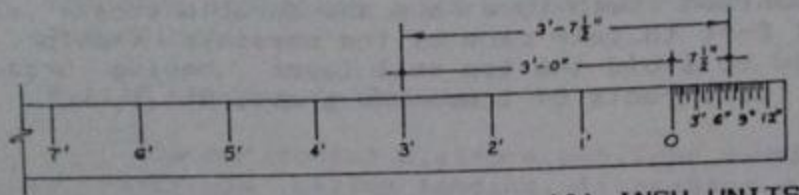

(A) INCH UNITS

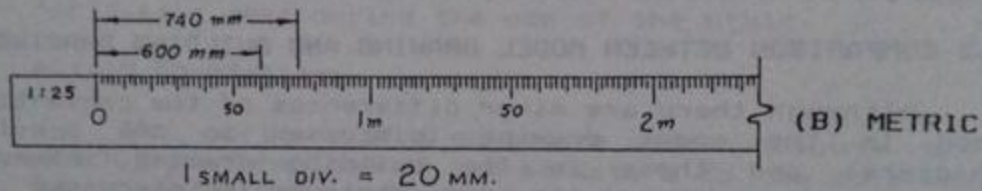

(B) METRIC

Fig. 6.7 Architectural Scales

On the architectural scales, the actual measurements are directly written taking into account the reduction factors. On one side of the zero-mark, we have the divisions showing feet of the building while the other side has another foot divided into 12 inches. To measure any dimension, first a point is selected corresponding to the whole feet dimension. After moving towards the zero of the scale and going beyond it, another point is selected representing inches of the actual structure. The distance between the two selected points will be the required dimension. For bigger scales the inches may have been divided into 2 or 4 parts while approximation for fractions of an inch is to be made for the smaller scales.

One scale is generally the biggest scale used by the Civil Engineers and that is why they may call it full scale although this term is misleading in the true sense as actual dimensions are not shown by this civil Engineer's full scale.

In metric scales direct ratio between the drawing size and the actual size is written. For example, 1:10 scale means that 1mm or 1m of the drawing line represents 10mm or 10m of the actual structure respectively. Other examples are 1:25, 1:50, 1:100 and so on.

Actual dimensions of the structure are written on the drawings regardless of the scale used.

6.2.2 Front Side:

The side of the building having main entrance is called front side whether it is the smaller or the larger dimension.

6.2.3 Angle of Projection:

In contrast to the model drawing where 3rd angle projection is used, 1st angle projection is still in use for the building drawing. Latest trends are to shift all types of drawings towards 3rd angle projection but there are two main difficulties. Firstly all drawings of the existing buildings are according to the 1st angle projection. Secondly all the unqualified labour is trained with time according to the old method and it is very difficult to make any change in this sort of life-long learning without any systematic education.

In 1st angle projection top view is drawn at the bottom and front view is drawn just above it. End view is drawn on that side of the front view which is opposite to the side from which we are looking at the object relative to the front. The article 3.10, especially Fig. 3.9 and Fig. 3.10, may be revised to have a clear idea about this arrangement of views. Sometimes, in building drawing, the end view is drawn on a different scale than the other views. In that case, it is not possible to draw E.V. exactly in line with the F.V., however, all the other principles of the 1st angle projection are still followed.

6.2.4 Terminology for Different Views:

6.2.4.1 Plan: In architectural or building drawing, top view is always drawn as a sectional top view formed by assuming an imaginary horizontal cutting plane just above the sill level. The view is drawn after removing the upper part and is termed as PLAN. Plan shows the position and the size of different elements of a building like wall thicknesses, position of beams, doors windows, almirahs and ventilators, etc., besides other optional details as sanitary fittings,

electric fittings, and furniture, etc. Simple top view is not used because of the reason that it will only show the parapet wall and the roof of a building and nothing else.

6.2.4.2 Elevation: Simple orthographic view used to show the appearance of the finished building is called elevation which is equivalent to front view in the model drawing. Elevation is only drawn for the super-structure, a thick line is drawn at the bottom showing the ground level and what is present above it is shown. This view is used only to communicate the appearance, hence, dimensioning is avoided in it. More than one elevations may also be drawn for a building namely front elevation, rear elevation, left elevation and right elevation. Sometimes elevations are named according to their directions, for example, N-elevation, S-elevation, E-elevation and W-elevation. Usually the most important view or the front elevation is drawn and is simply called elevation.

6.2.4.3 Sections: In place of E.V., drawn in the model drawing, section is drawn here. Section, in building drawing, is a term used for the sectional front view or end view of a building drawn to a suitably bigger scale showing both the super-structure and the sub-structure; maximum details and all the dimensions are given in it. Vertical cutting is assumed starting from the top of the parapet wall right up to the bottom of the foundation exposing all the hidden details like wall thicknesses, floor layers, roof layers, beams and lintels. Further heights of doors, windows, and ventilators as well as ceiling heights for various parts of the building are also shown. If the details are more complicated, more than one sections may also be drawn. Plan and section are completely dimensioned for each and every part.

Before starting with a particular section, its path of cutting must be shown in plan otherwise it will become meaningless. Direction of vision to obtain a sectional view is also shown on the cutting plane by arrows, triangles or some other suitable means. Each cutting plane and its associated section may be denoted by different letters or numbers.

Sections are drawn for clarity and to show even the smallest details in a way that these are easy to be read, hence, usually bigger scale is used for them. Sometimes sections are drawn on the same scale as that of the plan and elevation but are never drawn on a reduced scale. Double scale for sections is the most common practice. Appropriate symbols for the building materials in elevation (exterior

view) and section (after cutting), as given in Chapter No.4, are used.

6.2.5 Comparative Importance of Various Views:

Plan and sections are more important for a Civil Engineer as these contain all the dimensions and details required to carry out structural design. Elevation is relatively less important for a Civil Engineer, however, this view is very much important for an Architect. The clients may be convinced by the appearance of the building conveyed by the coloured elevations and perspectives. Sections are relatively less important for an architect except in certain special and complicated architectural designs.

In the model drawing all the views are carried out together to save time but, in the building drawing, plan is always completed first. Next step for an engineer is to show the path of cutting and then to start with the section. Elevation is drawn at the end consuming lesser time as far as possible.

6.2.6 Division of Drawing Space and Dimensioning:

The spaces in-between the views are kept approximately equal to each other in building drawing because the exact division of the space available for drawing is generally very difficult. Scale for the drawing is so selected that the spaces left in-between the views are sufficient to accommodate the dimensions and to separate the views. Further few dimensions may be written inside the views as compared with the model drawing but it is preferable to give dimensions outside the views as far as possible.

6.2.7 Dashed Lines in Building Drawings

In building drawing, hidden features are only shown by the method of sections and dashed line is not used to show them. The dashed line symbol is free to represent any other information on the drawing. In building drawing, dashed line is used to show certain important features in plan like beams, sunshades, lintels, etc., which are above the horizontal cutting plane and are removed with the upper part during the sectioning. These features which are removed with the upper part are not hidden features because these are not present inside the remaining part of the object after cutting.

6.3 DRAWING OF A BOUNDARY WALL:

Boundary wall is a simplest civil engineering structure consisting of a single wall present on periphery of the building. Functions of a boundary wall and an idea about its height are available in para 6.1.15. It is important to note that no external vertical load is coming on a boundary wall and a wall of minimum thickness should be suggested, except in certain special cases, to reduce its cost and to save the space available for the building. Minimum thickness of a

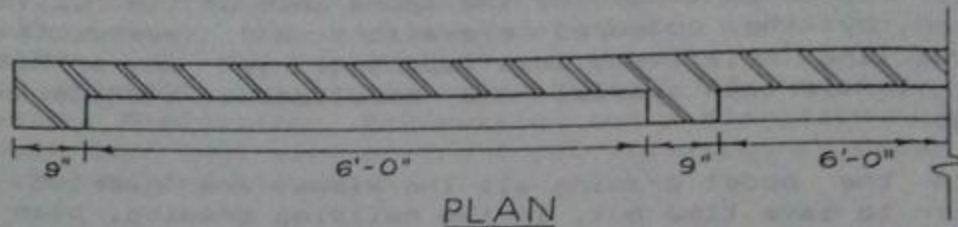

Fig. 6.8 Plan of a Simplest Boundary Wall

wall is 4 1/2-in obtained by placing a brick sideways but it is not stable and may overturn under the action of lateral pressure in case of heavy winds. For that it is strengthened at a minimum cost by providing 9"x 9" built-in columns at a spacing not exceeding 7'-0" C-C. These columns are just thickening of the wall at the required sections, one way to do so is shown in Fig.6.8. The other way, which is architecturally more attractive, consists of the construction of 4 1/2-in thick wall panels in an alternate way as shown in Fig. 6.9. It is to be noted that the wall thickness below the D.P.C. must be equal to the top thickness of the wall with a minimum of 9-in. The face of brickwork towards the mason during the construction becomes fair but the other side is usually not attractive and is later on plastered. The non-plastered brickwork in elevation is shown by horizontal lines at a spacing of 3-in whereas the plastered portion is left blank. From Fig. 6.9, it is to be noted that plan and elevation are always drawn on the same scale while double scale is preferred for the section. The drawing is to be started from the plan and for that the starting point may be considered by leaving a gap of about 1 1/2" from the lower border line and about 1 1/2-in from the left border line. Boundary wall is a long structure but is symmetrical in the sense that same pattern is repeated after regular intervals. Drawing is made for a selected portion which completely describes the pattern, generally 3 to 4 panels are shown, and then the wall is discontinued inside a

panel. The plaster thickness which is 3/8-in to 3/4-in is almost impossible to be shown on architectural scales and hence only a thick line is used for plastered face of the wall to represent the plaster thickness. Remember that the wall to represent the plaster thickness. Remember that the

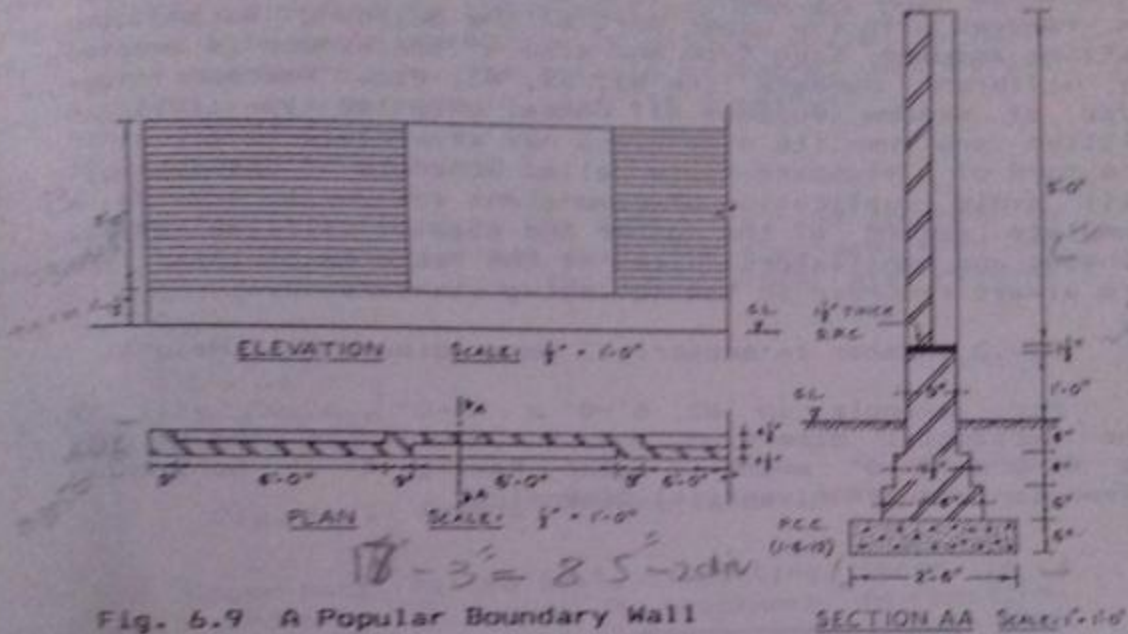

Fig. 6.9 A Popular Boundary Wall

symbol of brickwork in section is the repetition of two 45° lines about 1/16-in apart at a spacing of about 3/16-in. The lines may be conveniently drawn by marking two lines on the 45°-triangle and alternatively using them. Readers are referred to the article 4.1 for details of this method.

6.4 TYPICAL FEATURES PRESENT IN A BUILDING:

6.4.1 Windows:

When window is cut horizontally, as in plan of the building, an empty space is obtained between two ends of the solid wall. Symbol of brickwork in section will come in the solid wall but not in the space for the window as in Fig. 6.10 (A). Further from behind the cutting plane, two ends of the sill (the wall at the bottom of the window) will be visible. Window is always shown in the closed position meaning that two lines representing the thickness of the window itself are to be drawn. These lines may be drawn anywhere in the thickness of the wall with any suitable

spacing in-between, not according to the scale. These four lines will serve the purpose of a symbol for window in section. If sunshade is to be added on top of the window, as in external walls to protect the window from rain and sun, it must be shown by dashed line in plan because actually it is removed with the upper part of the building during the cutting assumed. Each type and size of the window is denoted by different numbers like W1, W2, W3, etc. Whenever same type of window (suppose W1) comes, only its type (W1) is written and then its dimensions may separately be given in the form of a standard table called Schedule of Openings. It will avoid duplication of dimensions and will provide a complete record of the number and size of all the doors, windows and ventilators. Sizes of the features of this type are always recorded in the following standard way:

W,V,D (Number in subscript) Horz. dimension x Height

For example, in W2 6'-0" x 4'-0", 6'-0" will be the horizontal dimension and 4'-0" will be the height. D1 4'-0" x 7'-0" means a door having 4'-0" horizontal dimension and 7'-0" vertical dimension.

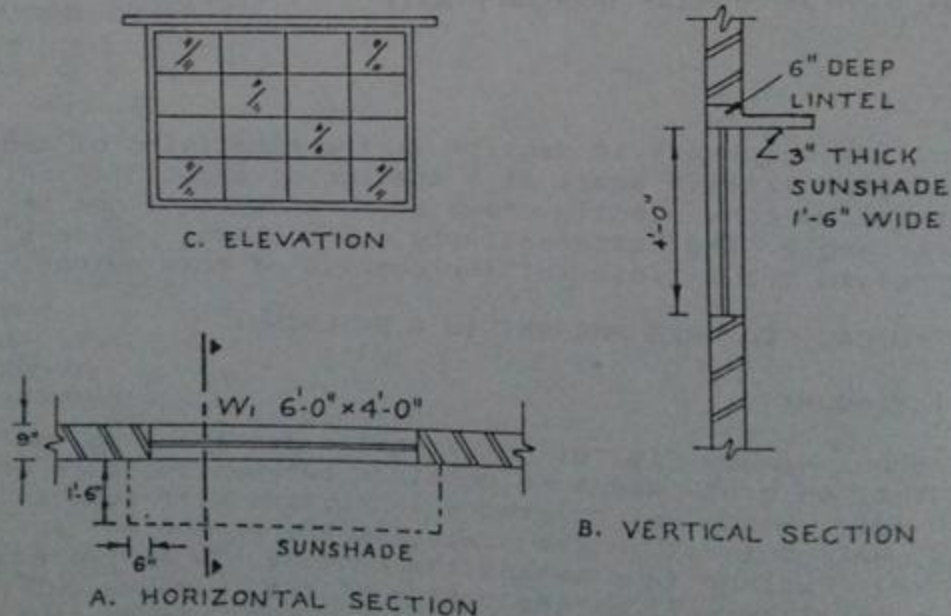

Fig. 6.10 Symbols of Window in Different Views

Window in vertical section is shown by four lines as in the horizontal section, see Fig. 6.10 (B). On top of the window, there is R.C.C. lintel shown by light green shade. Sunshade, if present, will be connected with the lintel shown by the same R.C.C. symbol. For elevation (or exterior view) of the window, as in Fig. 6.10 (c), the outer line is drawn exactly according to the dimensions whereas the inner pattern is only drawn symbolically without scale in main drawings of the buildings. The details of doors, windows and ventilators may be provided in separate drawings.

6.4.2 Ventilator:

Ventilator is denoted by the letter "V" and is shown in vertical section and elevation just like a window. When we assume cutting for the plan, the ventilators are removed

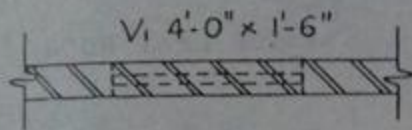

Fig. 6.11 Symbol of Ventilator in Plan

with the upper part. At the level of cutting, there is a solid wall shown by the symbol of brickwork in section. Symbol of a ventilator, just like a window, is then superimposed on the plan by using dashed lines. A window going near the ceiling is called ceiling window denoted by "CW".

6.4.3 Door:

Door is denoted by the letter 'D' and is shown in vertical section in closed position like a window. At the bottom of the door, the top floor finish layer will be continuous over the brick wall underneath. D.P.C. is not provided under the doors and all such openings which start from the floor level like verandah opening, etc. In plan, the door is shown in open position and, with a thin line, the space swing of the door during opening is also shown. The space between two ends of the solid wall is left exactly according to the dimensions of the door. Frame of the door is then drawn symbolically without the actual dimensions. Next, for a double leaf door, considering the inner edges of the frame as the centers, two arcs are drawn having radii equal to one-half the clear distance between both ends of the frame. Thick lines showing the leaves of the door are then drawn perpendicular to the wall. The advantage of this symbol is

that it also indicates the space consumed by the door during opening. Double-leaf door is preferred for wide doors and for the doors present away from the corners of the rooms. Single-leaf door should preferably be accommodated near the corner of the building leaving a gap of about 4 1/2" from

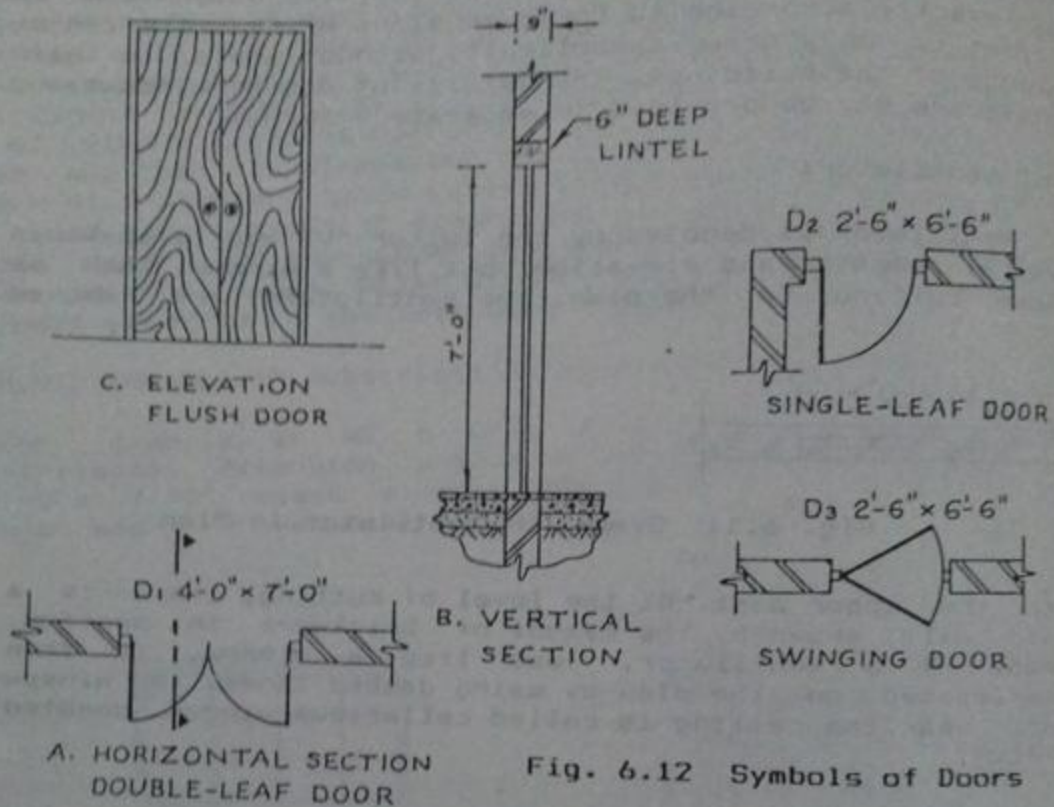

Fig. 6.12 Symbols of Doors

the other wall. The symbol is drawn nearly in the same way as that for a double-leaf door. A swinging door may open on both the sides and is preferred for kitchen of a residential building, clinics, and cafeterias, etc. In elevation, the door is shown according to its surface appearance. Flush door (having plane surface with pattern of the wood visible) is shown by the symbol of wood in elevation. A paneled door (divided into panels) is shown by drawing lines to show the pattern approximately without the actual dimensions.

6.4.4. D.P.C.:

Damp proof course (DPC) is provided inside all the walls which are continuous above the plinth level. Its top is generally made in level with the top of the floor. Its

thickness varies from 1 1/2" for residential buildings in ordinary soils to 3" for official constructions. The symbol of DPC in section is a dark black shade as shown in Fig. 6.13.

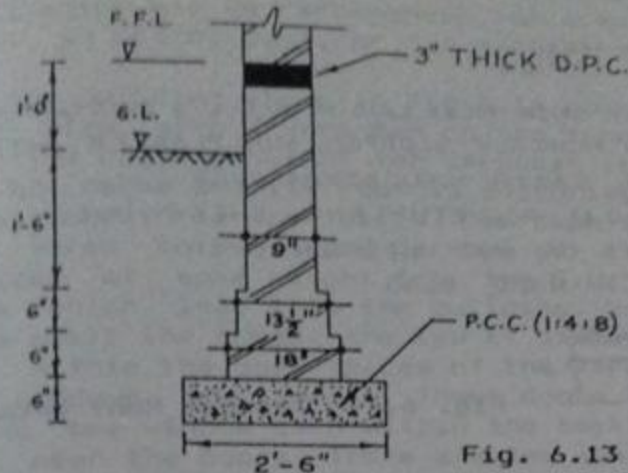

Fig. 6.13 Typical Foundation for 9" Thick Wall

6.4.5 Typical Foundation Details for a 9" Thick Wall:

The details for a typical foundation for 9" thick wall are shown in Fig. 6.13. It is preferable and time saving to draw a construction line first (serving as the center-line of the wall) and then to measure half distances from this line on both the sides. If this procedure is followed, the difference of measurement in different steps will not accumulate.

6.4.5 Roof Details:

Although there are many variations in the roof details depending upon type of the building, the typical details are produced in Fig. 6.14. At the top 1 1/2" thick layer of brick tiles is shown having brickwork symbol. Below this a single 4" thick layer is shown for both the mud plaster and the earth filling. Polythene sheet and bitumen coating have much lesser thickness and cannot be shown on an architectural scale; generally a thick line is drawn for these two layers. At the bottom, R.C.C. roof slab is shown by light green shade. A thick vertical line is then drawn upwards and a pointer is marked at a height so that all the roof details may be written within the space available between this pointer and the roof-top. Next, suitable guide lines for the lettering are drawn and each layer is

described in a separate line ending with the word 'over' starting from the top-most layer, as shown in the figure. Description of a layer includes its thickness and an idea about its material of construction.

▶ ROOF DETAILS

$1\frac{1}{2}$ " THICK BRICK TILES LAID IN (1:3) C/S MORTAR OVER
 1" THICK PROPERLY SLOPPED MUD PLASTER OVER
 3" THICK EARTH INSULATION OVER
 80 G./SQ.M. POLYETHYLENE SHEET OVER
 2 COATS OF HOT BITUMEN OVER
 6" THICK R.C.C. SLAB

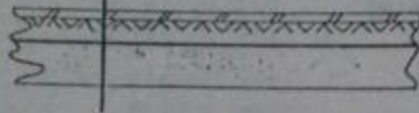

Fig. 6.14 Typical Roof Details

6.4.6 Floor Details:

Floor details are written in the same way as the roof details. Each layer is described in separate line and the description is started from the topmost layer. Compacted earth at the bottom of the ground floor has no definite thickness as the earth is continuous below.

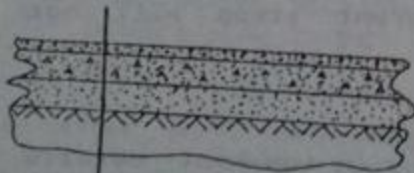

Fig. 6.15 Typical Floor Details

▶ FLOOR DETAILS

$1\frac{1}{2}$ " THICK FLOOR FINISH OF P.C.C. (1:2:4) OVER
 4" THICK P.C.C. (1:4:8) OVER
 4" THICK SAND FILLING OVER
 WELL COMPACTED EARTH

6.5 DRAWING OF A BUILDING:

After having practice to draw plan, section and elevation for important features of a building, drawing of a

small typical building may be started. A single room building may serve the purpose of a shop, clinic, cafeteria or a filling station office, etc. Two-room building may serve the purpose of a bus-stop, clinic, or post-office. Here a two room building with a verandah is considered in detail which may be recommended for a small primary village school, an octroi post, or for a check post.

The building shown in Fig. 6.16 consists of two rooms of equal size with a verandah on the front side in an open area. The ceiling height for verandah is lesser as compared with the rooms and its roof is supported over a beam present on all the three open sides. The beam in turn is supported over three columns and corners of the rooms. Floor is provided at some height from the G.L. and there are two steps which lead into the building. Note that risers are three while the treads are two as discussed in para 6.1.17. From within the open spaces of the verandah, two doors and two windows are visible. These doors lead into two rooms having one window each within the back wall and one window each near the doors. There are two almirahs present in the common wall one opening into the left room while the other into the right room.

If such a building is cut by a horizontal cutting plane 6-in higher than the S.L. and the upper part is removed, we get part of the building as shown in Fig. 6.17. This figure is the three-dimensional representation of the building after cutting with the arrow showing the entrance. The orthographic view of the same part, called plan, is shown in Fig. 6.18. The view is to be completely dimensioned. The dashed line present between columns of the verandah show the inner edge of the beam above. The outer edge of the beam is not shown by dashed line because full line is already there showing edge of the floor. While writing size of a room, its inner horizontal dimension parallel to the front of the building is always written first, then the other inner horizontal dimension is written with a "x" in-between. A 15'-0" x 12'-0" room means that 15'-0" dimension is parallel to the front side of the building.

Fig. 6.19 is a repetition of Fig. 6.17 but in it the path of cutting to obtain section is also shown by shading (cutting plane denoted by AA). This cutting is for whole of the building starting from the top of the parapet right up to the bottom of the foundations. After assuming this cut if we remove the left part of the building, the remaining portion will look like Fig. 6.20. This cutting exposes nearly all the details like roof layers, floor layers, lintels, sunshades, beams, thicknesses of walls, ceiling

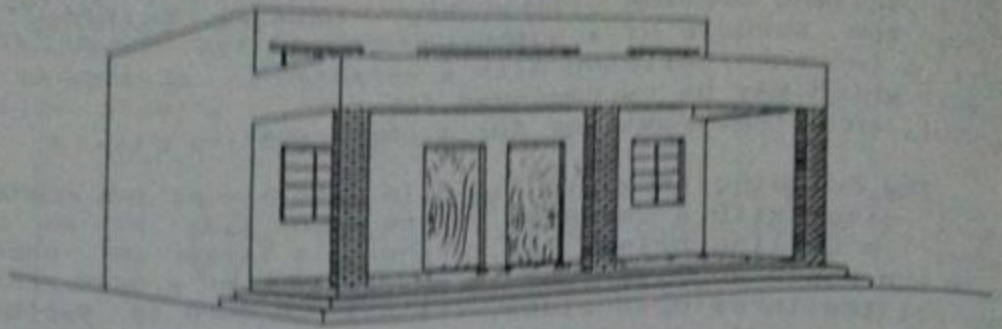

Fig. 6.16 Perspective of a Building
With Two Rooms and a Verandah

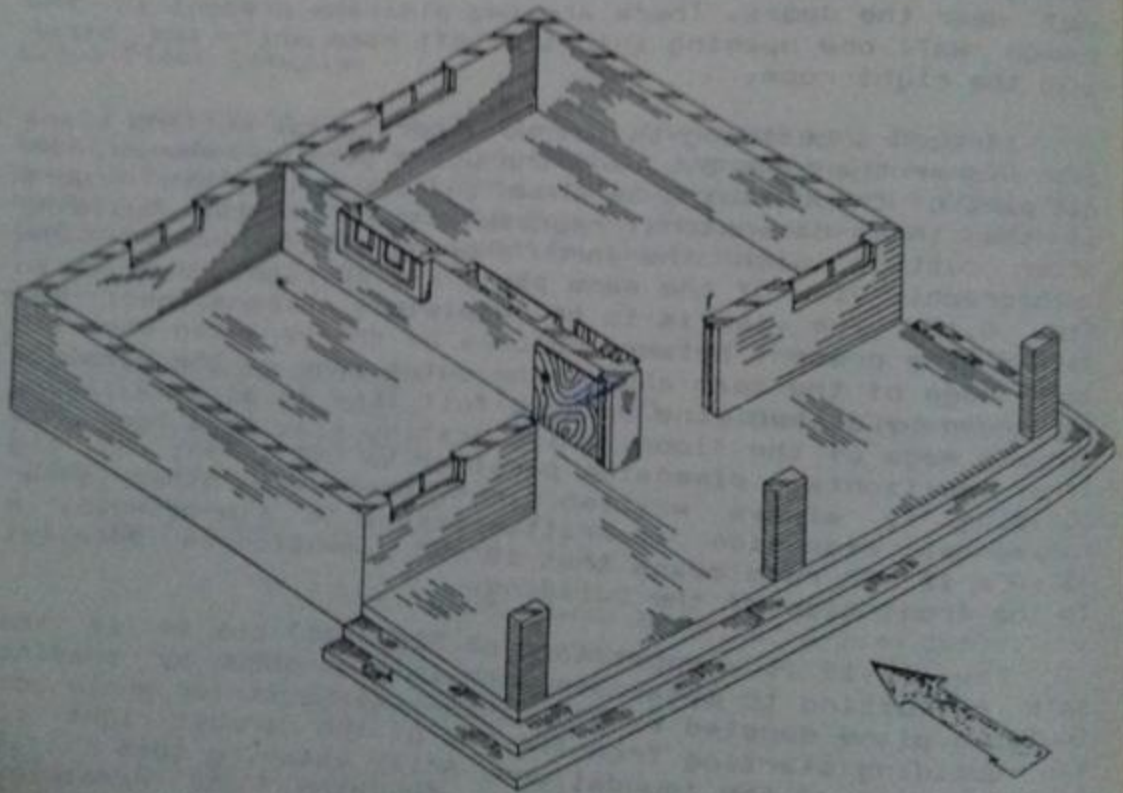

Fig. 6.17 Isometric View of the
Building After Cutting for Plan

heights, heights of doors and windows, and foundations etc. That is why section is the most important view in the Building Drawing. The three dimensional view from one side, Fig. 6.20 provides an idea of the sectional view from one side, whereas, it may also be used to have an idea about the

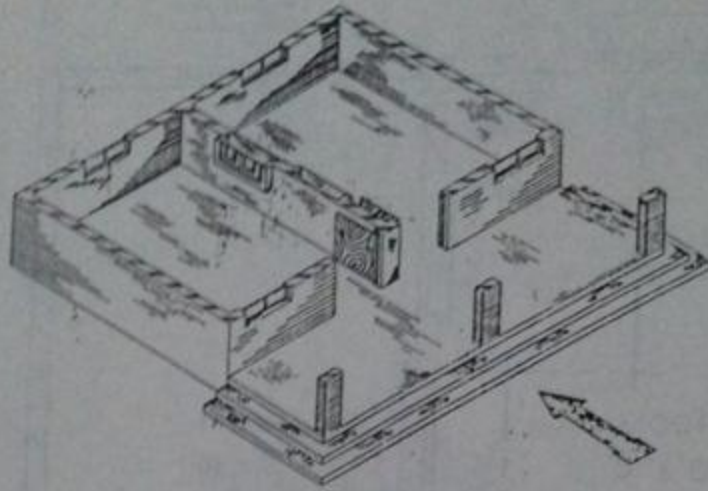

Fig. 6.19 Same as Fig. 6.17 With Cutting Plane for Section AA

elevation when looked from the other side. Interrelationship of various features shown in section and in elevation may also be established from the same figure. The orthographic view of the same part of the building is shown in Fig. 6.21, called Section. Maximum details and all the dimensions are written in this view.

The three views are arranged on the drawing sheet according to 1st angle projection as shown in Fig. 6.24. The division of the space for these views will be approximate. The starting point for the plan may be considered at the bottom-left corner of the sheet about 1 1/2" from the left border line and about the same from the bottom border line. Plan is now constructed according to its dimensions with its bottom-left point coinciding with the selected point. Elevation is drawn after completing the section just above the plan such that approximately equal spaces are left on the top and in-between the two views. Section is drawn on the right side (because left E.V. is selected here) on the same scale or preferably on double the scale. In this case also equal spaces are left on the top and the bottom and the left and the right.

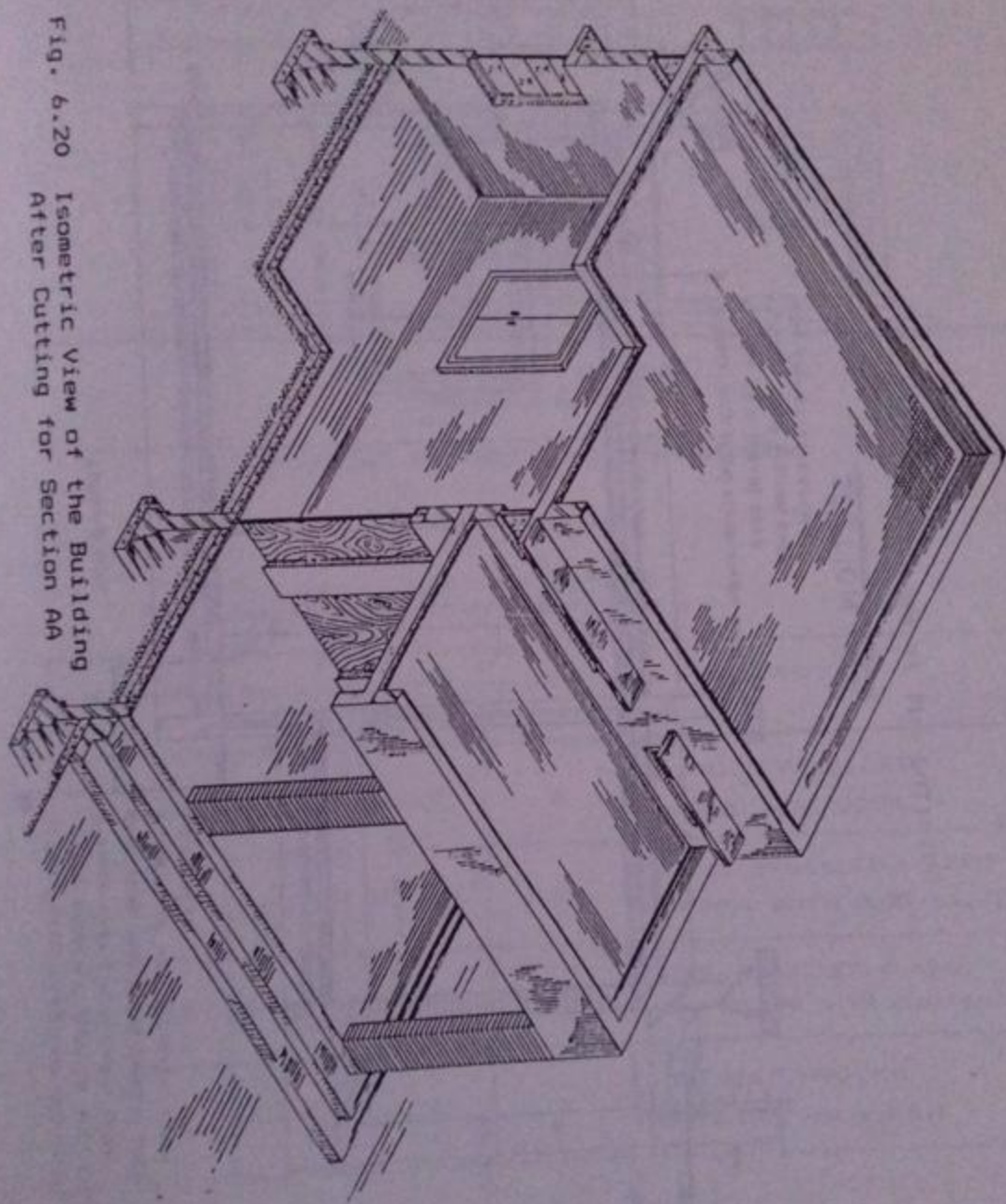
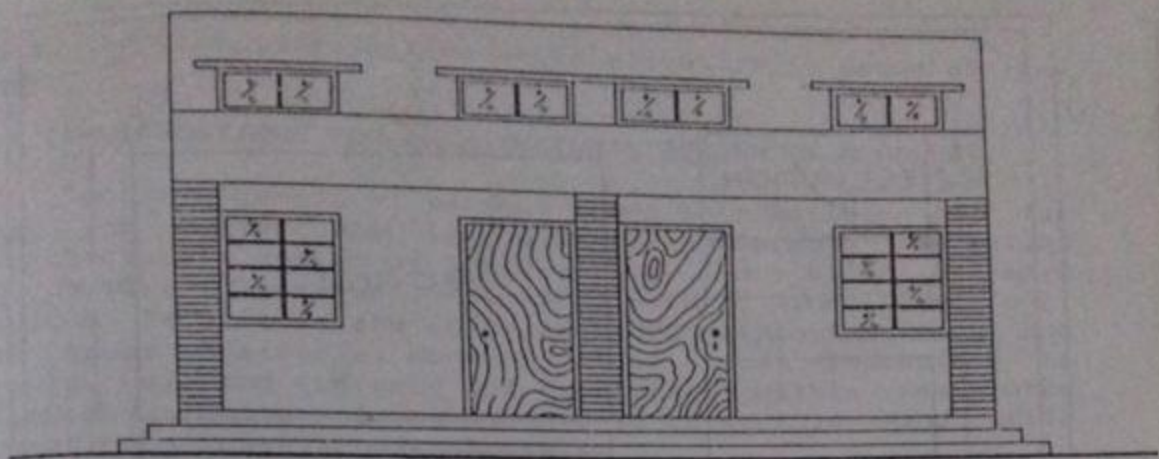

Fig. 6.20 Isometric View of the Building
After Cutting for Section AA



ELEVATION

Fig. 6.22 Elevation of the Building

SCHEDULE OF OPENINGS

S.NO.	ITEM	SIZE	SILL LEVEL W.R.T. P.L.	QUANTITY	DESCRIPTION
1	DI	4'-0" x 7'-0"	0'-0"	2	WOODEN PANELLED SINGLE LEAF DOOR
2	WI	4'-0" x 4'-0"	+3'-0"	4	STEEL PANELLED GLAZED WINDOW WITH WIRE-GAUZE
3	VI	4'-0" x 1'-6"	+10'-6"	6	STEEL PANELLED GLAZED VENTILATOR WITH WIRE-GAUZE
4	ALI	4'-0" x 4'-6"	+2'-6"	2	10½" DEEP WOODEN SHELVED ALMIRAH

Fig. 6.23 Schedule of Openings

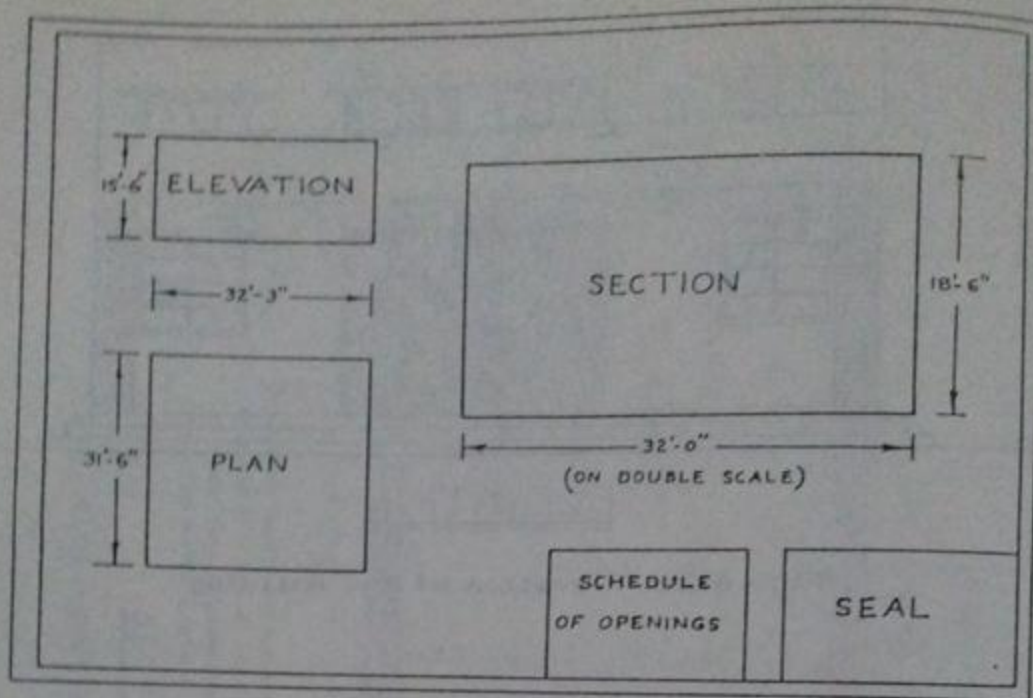

Fig. 6.24 Arranging Views on the Sheet

Scale for the views must be as bigger as possible accommodating all the figures with sufficient spaces in-between. First larger scale is tried and according to the dimensions of the views, it is checked whether the views will be drawn properly or not. If space is lesser for this scale, reduce the scale. Repeat the procedure until a suitable scale is selected. Schedule of doors and windows may be drawn anywhere on the sheet where space is available. This table contains information about doors, windows, ventilators and almirahs including their designation, size, quantity or number, sill level and the description in a sentence. The description includes the type of that opening and material of construction, etc., such as:

- Single leaf flush doors with wooden frame
- Wooden paneled double leaf doors
- Steel glazed windows with wire-gauze
- Wooden glazed ventilators.

Each view is labeled and scale is written for it. It is important to recall that plan is always drawn first showing the path of cutting to obtain the section. A Civil Engineer

will then complete section while elevation is drawn at the end.

6.6 CONSIDERATIONS FOR ARCHITECTURAL DESIGN OF A HOUSE:

The arrangement of various rooms in a building plan for easy and comfortable living of the occupants is called architectural design of the building. Every effort is made to utilize full natural resources such as wind, sun, etc. Maximum facilities are to be provided within the funds and the space available. However, it is almost impossible to provide all the comforts and facilities within restricted resources. Following points are to be kept in mind while designing a house architecturally.

6.6.1 Plot size is measured in Sft., Sq. Yds., Marlas or Kanals with the following conversion.

- 1 Sq. Yd. = 9 Sft.
- 1 Marla = 225 Sft.
= 25 Sq.Yds.
- 1 Kanal = 20 Marlas
= 4500 Sft.
= 500 Sq.Yds.

Rectangular plot is preferable with the ratio of longer to shorter side roughly equal to 1.85.

- Standard size of 10 marla plot = 35' x 65'
- Standard size of 1 kanal plot = 50' x 90'

6.6.2 Plot is to be divided into a central constructed block and open spaces left at least on three sides. Bye-laws of the controlling authorities for the urban construction must be observed in all respects. For example, for a 10 marla house, the most common restriction on the covered area is that it should not be greater than 60% of the total plot area and 10 ft. wide open spaces should be left on the front and the backside while a minimum of 5-ft open passage is to be provided on at least one side. Within a certain constructed area, covered area may be increased by increasing the number of storeys. A two storeyed building is about 20% economical than single storeyed building. Most important factor to decide about the covered area is the finance. The covered area may roughly be found out from the following relation knowing the average cost of construction per unit area.

Total covered area (A) = $\frac{\text{Available funds}}{\text{Construction cost per unit area}}$

141

Walls cover about $1/7$ th of the covered area of an ordinary house and the effective area available for living is $(A - A/7)$ or $0.85 A$. As far as possible, the constructed block should be kept square instead of rectangle. Area of the walls in case of square space is about 15 to 20% lesser than in case of a rectangular space.

6.6.3 Modern design of a house should include the following components:

a) Bedroom with Attached Bath:

This room should be located on open side or back periphery of the constructed block to maintain good natural ventilation and light. Bedroom should be made as independent and private as possible but it should have easy access to all the common places in the house. Further it should be prevented from direct sun and rain. Minimum size of a bedroom for a small house is at least 100 Sft, for example, 8'-6" x 12'-0". Reasonable size is 180 Sft like a bedroom of size 12' x 15'. The bathroom to be provided should have a minimum size of 30 Sft and at least one side of it must be towards the open side for better ventilation. Sometimes a small portion called dressing is also provided close to the bath. Passage of the bathroom, in this case, is through the dressing. Area of the dressing room may be kept smaller even about 25 Sft. One or two cupboards or wardrobes must be provided in each bedroom or in the attached dressing. Minimum depth of the cupboard should be 1'-9".

b) Drawing Room:

Preferable size is about 215 Sft with a minimum of 110 Sft. It should be made well ventilated and lighted and should have a direct approach from the main entrance of the building. A powder room having a minimum size of 12 Sft is to be attached with the drawing directly or through the living room. The powder room is to be fitted with a W.C., a wash hand basin and hangers.

d) Living Room:

It is sometimes referred to as Common Room or TV Lounge. Living room should be the central place of a house and direct access to all other components should be available from here. This place should be the most comfortable and graceful part of the house so that the occupants are attracted to it and a common sitting is automatically arranged at suitable times. This room should give an impression of being open. If greenery is visible

from inside the living room, the architectural appearance is improved and for that large glazed windows on suitable sides may be recommended. This room is generally the biggest place in the house having an area ranging from 215 to 325 Sft.

e) Dining Room:

This room having a minimum size of about 150 Sft should be located adjacent to the drawing and the living room. Kitchen should also be connected to the dining room for easy working. Sometimes a pantry (having about 50 Sft area) in-between the kitchen and the living is provided to store the kitchen articles and the cooked food temporarily. This room should have cupboards and shelves.

In modern houses, drawing, dining and living rooms may be combined in any required pattern. In that case, area requirements are slightly reduced.

f) Kitchen:

Reasonable size for the kitchen is about 80 Sft but it depends upon the plot size, number of members of the family and the way in which the kitchen is used. Ventilation should be very good and space may also be provided for exhaust fan.

g) Store or Box Room:

It is a small (about 50 Sft) but safe room present in the interior of the building to store valuable articles.

h) Stair Case:

Position of the stairs is also very important which may be provided in a separate stair hall or directly in the living. If stair hall is to be provided, it should preferably have one opening to the outside and one to the living room so that the upper storey remains somewhat separate yet easily approachable from the ground floor. Natural light should always be available for the stairs.

i) Verandah:

It may be 6'-0" to 10'-0" wide and should be located on either the front or the back of the building.

j) Servant Room:

For one kanal or bigger house, a servant room may be provided having a size about 100 Sft. If it is on the ground

floor, it should be independent and on the back side of the house but if it is on the top floor, preferably it should have a separate approach usually by steel stairs. A bathroom should also be provided with it.

k) Car Porch or Portico:

Car porch is constructed in front of the building to park the car. It is generally a roof provided over pillars, boundary wall or already constructed walls open from two or three sides.

l) Corridor:

It is covered passage inside a building to provide approach to a room without disturbing the working of the other rooms. Corridors should be avoided as far as possible.

m) Lobby:

It is a small place or hall at the main entrance which is connected to the living room and the drawing room.

6.6.4 Doors and windows should be minimum as they increase the cost and utilize the available space yet they should provide adequate means of ventilation and light. Area covered by the windows should not be lesser than 15 to 20% of the floor area of the room. Windows and doors on opposite faces provide better cross ventilation. The main doors to the constructed block should be 4'-0" x 7'-0" in size so that the heavy articles may be moved into the house without any obstruction. Doors for the bedrooms may be 3'-6" x 7'-0" in size while the door of a bath may be as smaller as 2'-6" x 6'-6" in size. Size of the main gate fixed in the boundary wall depends upon the factors like easy parking of the car. It may be about 8 ft wide.

6.6.5 Arrangement of different components should be such that minimum space is wasted in passages and corridors. Bedrooms, kitchen and bathrooms should be rectangular for better utilization of the space. The length over breadth ratio should be about 1.25 up to an area of 200 Sft and 1.5 after that. Bathrooms and kitchen should have at least one side open for proper ventilation and for the reason of easy supply of services like water, sewerage, and gas.

6.6.6 Ceiling height is selected keeping in view the points already mentioned in para 6.1.8.

6.6.7 Proper attention should be given to the orientation of

the plot with respect to the North. The sun rises from the East and goes towards the West but its passage is dipped towards the South. The side of the building towards the South or the South-East is generally very hot in summer and also light becomes excessive on this side. Verandah, bathrooms, and stores may be provided here while drawing room, dining room, living room and bedrooms are usually saved. Further towards the South and the South-West, as the light is usually excessive, windows are generally made narrow with proper sunshades.

For maintaining good ventilation inside the building, longer sides of the building should be exposed to the wind direction. Wind normally blows from the South-West South-West or the North-East direction, it is advantageous.

6.6.8 In architectural design, much more attention is given to the elevation. Elevation is the appearance of the building from the front or from the outside which has a great impact on the shape of the building. It is usually decorated with glazed windows, arches, planed projections of walls and by special finishes on the wall surfaces. Sometimes grills of reasonable design also add to the beauty of the building. For some cases, even up to 30% of the total cost is spent on the elevation.

6.6.9 Ground floor plan and first floor plan should be so adjusted such that most of the walls of first floor comes directly above the walls beneath because providing beams increases the cost. However, in certain cases, we have to provide some walls which have no support of walls below.

6.7 ADJUSTING PLANS OF ORDINARY BUILDINGS:

i) Depending upon funds available, plot size and requirements, fix the sizes of the main components like bedrooms, drawing room, dining room, living room, and kitchen, etc.

ii) Add 9-in in each dimension for half wall on the two sides and draw the above components separately on a graph paper according to some suitable scale. Cut rectangles for each component.

iii) On another graph paper draw the boundary of the plot according to the same scale and draw lines to separate the necessary open spaces.

iv) Try to adjust the different components in a suitable

way by placing the rectangles over the plot-area to be covered. Make different trials to achieve the best solution keeping in mind the position of the doors to be provided. Generally it is difficult to fulfill all the requirements and, in that case, we have to consider the preferences.

v) According to the selected pattern, roughly draw the plan on the graph paper making small adjustments.

vi) Decide about the position of doors, windows, ventilators, almirahs, exhaust fans, and air-conditioners. If these features cannot be adjusted accurately reconsider the arrangement.

6.8 TYPES OF CIVIL ENGINEERING DRAWINGS:

1. Proposal drawing or proposal sketching
2. Perspective
3. Submission drawing
4. Working drawings
5. Completion drawing

6.8.1 PROPOSAL AND PERSPECTIVE:

First architect collects data and requirements for the building such as the funds available, plot size, use of the building, number of stories desired, north direction, plot-level especially in comparison with road level, required room sizes, etc. Then he makes a number of proposals keeping in mind the by-laws of the controlling authorities. For proposals, plans and elevation are drawn on a very small scale like 1/8 or 1/16 while the section is usually not needed. Plans and elevation, in these drawings, are made attractive even by colouring and, if needed, perspectives are also drawn to impress the client.

The proposals are then discussed with the client and changes are made according to his wishes. Sometimes, if the client dislikes the proposals altogether, new proposals are to be made. Offering of proposals is continued till the client is satisfied with a certain plan.

6.8.2 SUBMISSION DRAWING:

Submission drawings are actually legal documents used to approve the plan from the controlling authorities like LDA and LMC.

Plans (ground floor plan, first floor plan and so on), an elevation and a section is drawn in these drawings. Plans

are most commonly drawn on 1/8 scale. Section here is used to give important heights but all the details are not required. That is why it is also drawn on 1/8 scale and is taken through such a portion so that it is the simplest sectional view.

Site plan is required in the submission drawings for plots greater in size than 10 marlas. Site plan shows the block of actual building or the constructed portion as compared to the total plot area. It is drawn on a very small scale like 1/16 or 1/32. If site plan is included in the drawing, the main plans are only drawn for the constructed portion without showing the open spaces and the boundary wall. Various services are also shown in the site plan, for example, if sewerage line is passing, two or three man-holes of the main line are shown and then connection for the plot is indicated. Further comments are written like "disposal to WASA Sewerage Line" etc.

Fig. 6.25 Site Plan

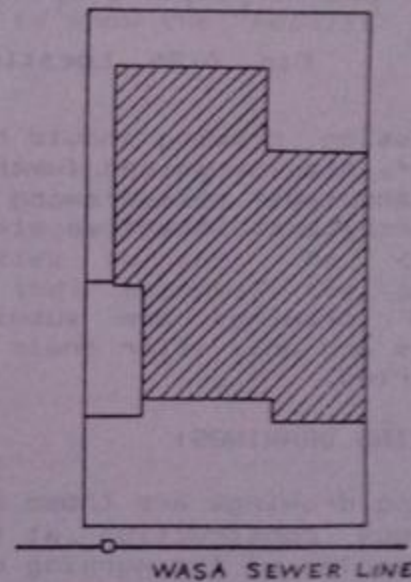

Location plan is also drawn to indicate the location of the plot, on a scale like 1/64. It is a part-plan of the total scheme; one or two main roads with their names and neighbouring plots are shown.

Doors, windows and ventilators are marked by D1, D2,....., W1, W2,....., and V1, V2,..... in the plans. The sizes of these components and other related details are given in the form of a table called Schedule of Openings.

Statement of Areas or Schedule of Areas is also prepared in tabular form in which total area of the plot,

covered area, allowable covered area, ground floor covered area and first floor covered area etc. are given.

SECTOR E, NEW TOWN

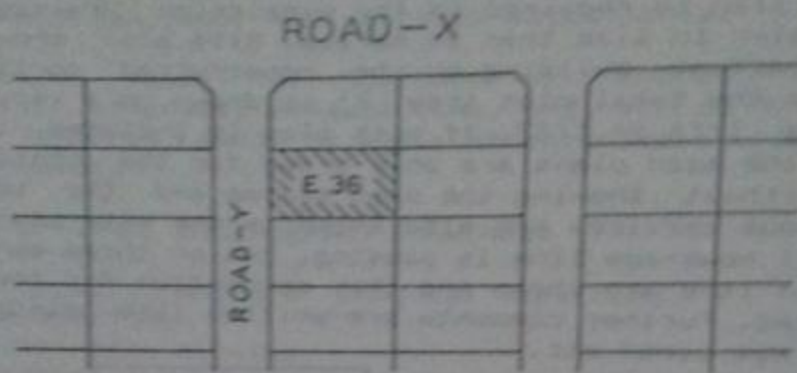

Fig. 6.26 Location Plan

Submission drawing should have the name and complete address of the owner and further it should be properly signed by the owner. The drawing should also be signed by a licensed architect. Sometimes stability certificate is also required.

These drawings are submitted to the controlling authorities and only after their approval, the construction can be started.

6.8.3 WORKING DRAWINGS:

Working drawings are those drawings which are used for carrying out construction at the site according to the design. Examples of the working drawings are as follows:

- a) Architectural working drawings
- b) Structural working drawings
 - i) Foundation plan
 - ii) Reinforcement details
 - iii) Plumbing works
(Plumbing means the water supply and its disposal inside the building)
 - iv) Details of doors and windows
 - v) Bathroom and kitchen details
 - vi) Electrification plan

After approval of the plan, through the submission drawing, architectural working drawings are made in which all the details are given which are necessary for the at-site construction. The sections are drawn on enlarged scales and as many number of sections are used as needed to clearly explain the structure. On blown-up scales, stair details and details of kitchen and bathrooms etc. are also shown. Further, position of various types of furnitures is also indicated in the plans. More than one elevations are drawn to represent the shape from different directions.

In working drawings, we can make small changes from the approved plans like alteration in the position of doors and windows and small adjustments in the internal sizes of the rooms.

After structural and plumbing design of the building, working drawings are made to show the results of these designs.

6.8.4 COMPLETION DRAWING:

After construction of the building, drawings are made according to the actually constructed features called completion or as-built drawings. These drawings are then submitted to the authorities to get the completion certificate and only after their approval the owner can legally occupy the building.

PROBLEMS

6.1 Observe different types of boundary walls constructed for houses and offices. Select one which you prefer architecturally, function-wise, and from economic point of view. Measure the visible part of the wall, suggest changes if you like, and complete it by providing suitable foundation. Make rough sketches for Plan, Section and Elevation and discuss these with your instructor. Transfer the design on the sheet in the form of a proper drawing using 1st angle of projection.

6.2 For a filling station office building consisting of a single room 10' x 8', draw Plan, Section and Elevation. The roof is projecting 3 ft. on the three sides and plinth is 1'-6" higher than the adjoining ground. Suggest suitable values for all other data required.

6.3 Make drawing of a bus-stop building consisting of two compartments 8' x 6' with plinth 1'-0" higher than the G.L. Fulfill all other requirements yourself.

6.4 For a site-office in an open area consisting of two rooms 15' x 13' and a verandah 7'-0" wide, make a drawing according to 1st angle projection. Plinth level is to be kept 2'-6" higher than the G.L. Ceiling height for the rooms is to be 13'-0" and for the verandah it is to be 8'-6".

6.5 For a plot of size 40' x 60', adjust plan on a graph paper for the following requirements:

- a) One bedroom with attached bath (15' x 12')
- b) Car porch (for one car)
- c) Verandah (optional)
- d) Living room (about 200 Sft)
- e) Drawing/Dining room (18' x 13')
- f) No stairs
- g) All the necessary components are to be included.

CHAPTER NO.7

INTERSECTION AND DEVELOPMENT OF SURFACES

7.1 SURFACES

A surface is a geometric shape having two dimensions with negligible thickness but it may lie in a three dimensional space. The surface may be formed/generated by moving a line, called the GENERATRIX of the surface. Any position of the generatrix is an element of the surface. The line showing path of motion of the generatrix is called the DIRECTRIX. The surface generated by moving a straight line along any path is called a RULED SURFACE. The surface generated by moving a straight line generatrix parallel to its original position along a straight path is called a PLANE.

A SINGLE-CURVED SURFACE is a ruled surface that may be generated by moving a straight line along some curved path; examples are the cylinder and the cone.

7.2 COMMON TYPES OF SURFACES

7.2.1 Prism

A prism is a polyhedron (shape with multiple faces) having identical and parallel bases (or ends) connected by lateral faces which are parallelograms. The axis of a prism is a straight line connecting the centers of the bases.

7.2.2 Pyramid

A pyramid is a polyhedron whose base is a polygonal plane and whose other surfaces are triangular planes converging to a single point called the VERTEX or the APEX. The axis is a line joining the apex and the center of the base. The altitude is the perpendicular distance from the apex to the base.

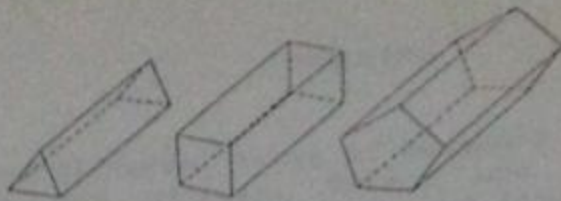

Fig. 7.1 Prisms

7.2.3 Cylinder

A cylinder is a single-curved surface generated by moving a straight-line generatrix along a curved path/directrix such that the generatrix remains parallel to itself.

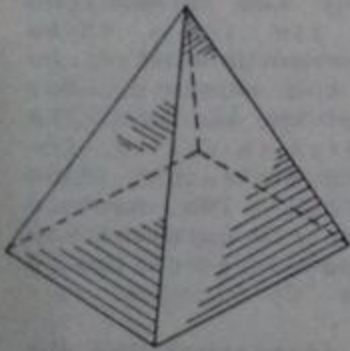

Fig. 7.2 Pyramid



Fig. 7.3 Cylinder



Fig. 7.4 Cone

7.2.4 Cone

A cone is a single-curved surface generated by a straight line generatrix one end of which remains fixed at a point called VERTEX of the cone while the other end moves along a curved directrix called BASE of the cone. Axis of the cone is a line joining the vertex and the center of the base.

7.2.5 Truncated Shape

A truncated shape is that portion of a geometric shape which lies between the base and a cutting plane cutting all the elements.

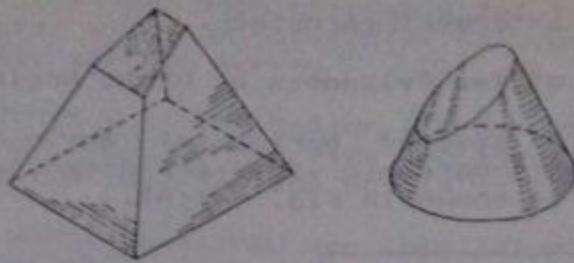

Fig. 7.5 Truncated Pyramid and Cone

7.2.6 Frustum of a Shape

Frustum of a shape is that portion of the geometric shape which lies between the base and a cutting plane parallel to the base cutting all the elements.

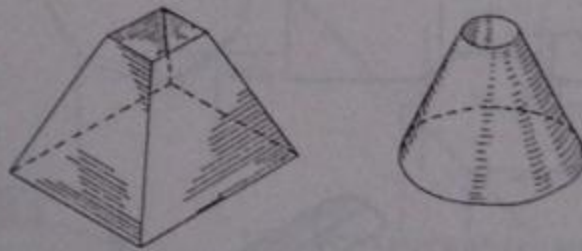

Fig. 7.6 Frustum of Pyramid and Cone

7.2.7 Right Shape

If the axis of a shape is perpendicular to its base, then that geometric shape is termed as a right shape. Examples are a right cone and a right pyramid as shown in the above figures.

7.3 INTERSECTION OF SURFACES

While making orthographic drawings, the intersections between the various types of surfaces are to be shown by certain lines. For example, when two planes intersect, a straight intersection line is obtained. Intersection of surfaces especially means the complicated lines obtained when geometric shapes such as planes, cylinders, prisms,

pyramids and cones intersect each other.

7.3.1 Intersection of Two Cylinders at Right Angles

a) One cylinder is assumed horizontal while the other vertical and three orthographic views are drawn leaving the intersection line, as shown in Fig. 7.7(A).

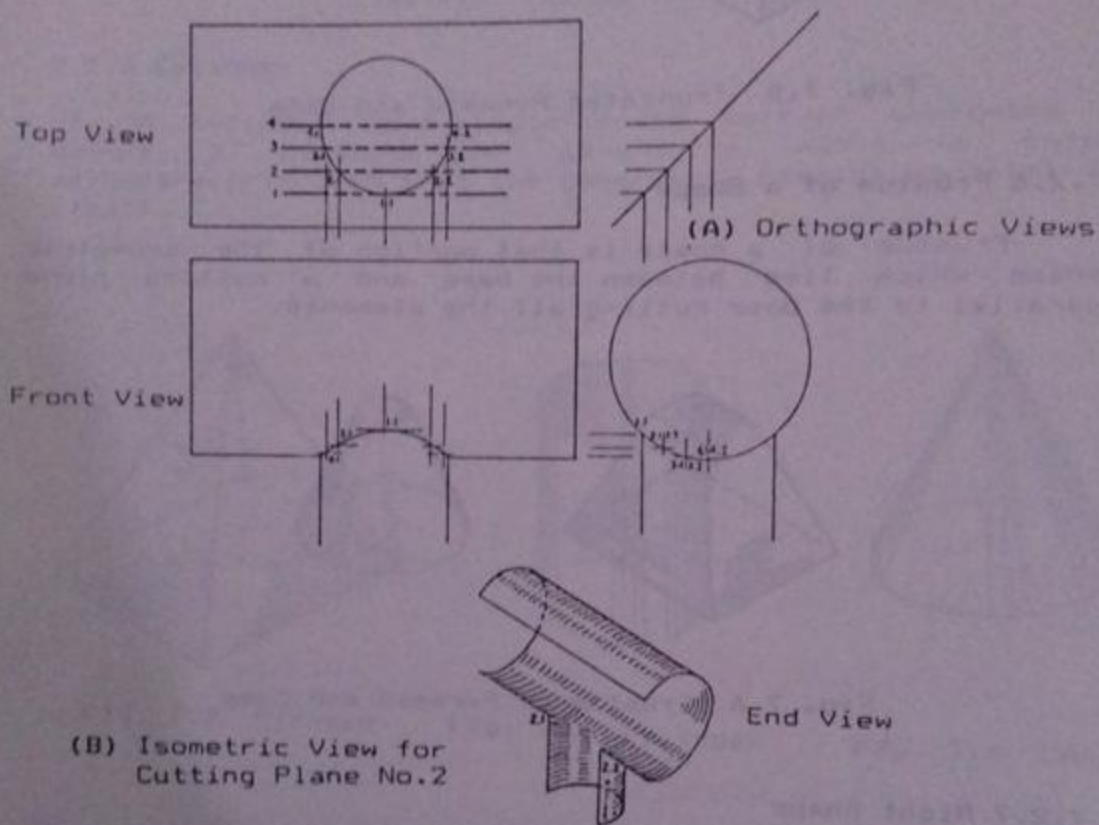

Fig. 7.7 Intersection of Two Cylinders

b) Frontal cutting planes 1,2,3, and 4, etc. are assumed parallel to the axes of both the cylinders as shown in the top view. The isometric view after cutting with plane-2 is shown in Fig. 7.7(B). The intersection points of this plane with the smaller cylinder, 2.1 and 2.2, can easily be located in the top view and the isometric view. These points will be included in the final intersection curve as is clear from the isometric view.

c) The assumed cutting planes are projected from the top

view to the end view through a 45° line. The points of intersection with the horizontal cylinder will be the points of the intersection curve.

d) The points of intersection are projected horizontally and vertically from the end view and the top view respectively to locate the intersection points in the front view.

e) The points obtained are then joined by a smooth curve which will be the required intersection curve between the two cylinders.

7.3.2 Intersection of a Cylinder and a Right Cone

Three views of the cone and the cylinder are drawn first as shown in Fig. 7.8(A). The cylinder in the E.V. is then divided into any number of equal parts, twelve in this case. The points A, B, C, D, E, F and G in the figure show the

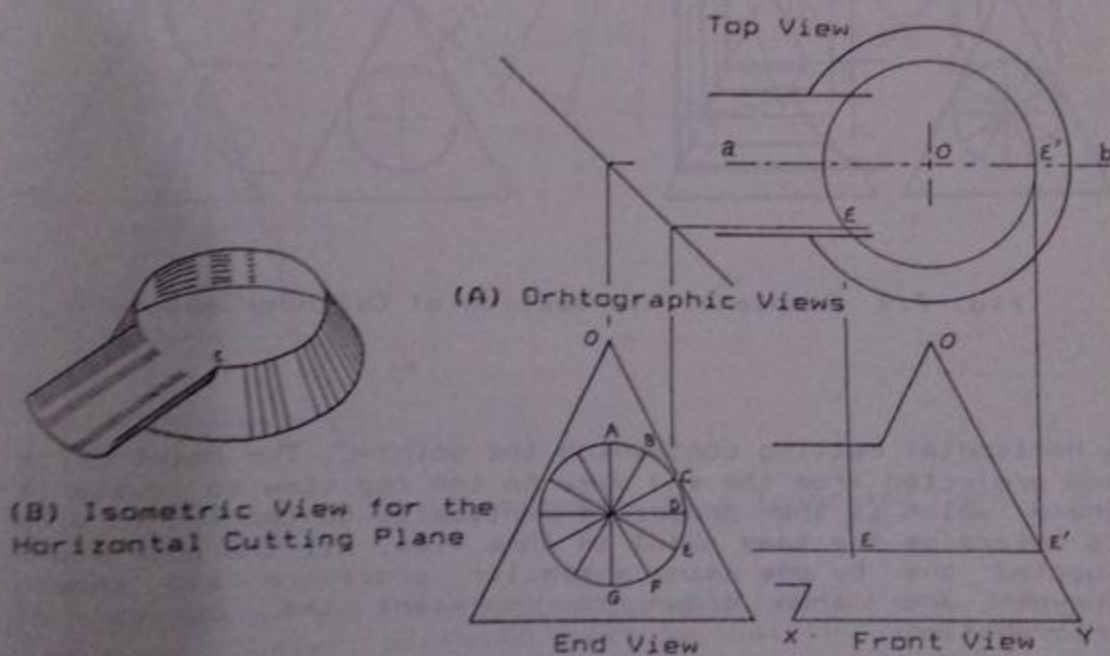

Fig. 7.8 Starting the Intersection of Cylinder and Cone

points of intersection of the cylinder with the cone as seen from the end. Each point is separately considered and is located in the other two views. To locate point-E in the top and the front views, a horizontal cutting through point-E is assumed removing the upper part as shown in Fig. 7.8(B).

Horizontal line at the height of the point-E is drawn in the front view showing the horizontal cutting. Point-E thus obtained in the front view is projected to the top view to intersect the center-line 'ab'. A circle is drawn passing through this point with center at 'D' in the top view, showing the top edge of the frustum of the cone left after

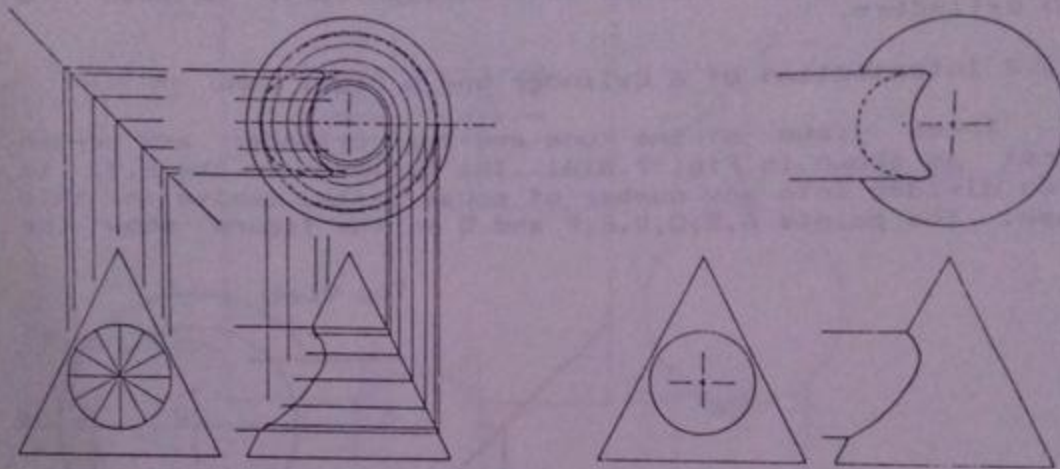

Fig. 7.9 Complete Intersection of Cylinder and Cone

a horizontal cutting containing the point-E. The point-E is now projected from the end view to the top view to locate it there which is then projected vertically to the front view to determine the same point in this view. All the points are located one by one using a similar procedure and smooth curves are then drawn to represent the curves of intersection.

7.4 DEVELOPMENT OF SURFACES

When a curved surface is unfolded to a single plane, the resulting figure is called development of that surface. By using these surface developments a pattern layout of any object can be constructed on some plane sheet which may then be used to form the required shape.

Application of surface developments are found in metal

sheet, plastic sheet and paper sheet fabrications.

7.4.1 Development of a Truncated Right Circular Cone

a) Top view and front views of the cone are drawn first and the truncating line is shown in the front view.

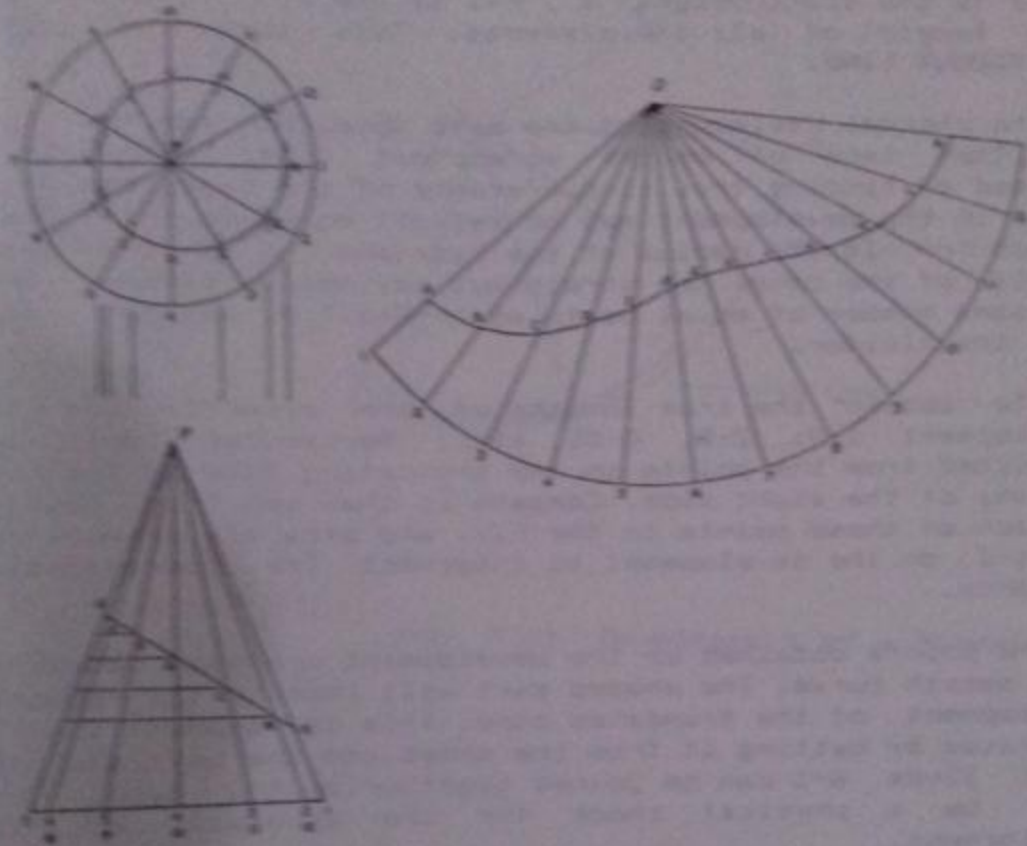

Fig. 7.10 Development of a Truncated Cone

b) The base of the cone in the top view is divided into a sufficient number of equal parts so that the sum of the resulting chordal distances closely approximate the periphery of the base. In Fig. 7.10 the base is divided into 12 equal parts by drawing lines at 30° , 60° and 90° angles from the central point. The points on the circle are numbered as shown in the figure.

c) The points on the base are then projected down to the front view and are then extended to the apex of the cone. The points of intersection with the truncating line are named by capital alphabets A, B, C, D, E, F and G as shown.

d) The points A to G are then projected to the top view to meet the corresponding elements. The points thus obtained are joined with a regular curve to form the top view of the truncating part.

e) From a separate center 'O', a curve is drawn with radius equal to the slant height 's', P-1 in the F.V., showing the true length of all the elements. This curve is called STRETCHOUT LINE.

f) The chordal divisions of the base obtained from the T.V. are then laid off on the stretchout line. Alternately, instead of finding true circumference of the base, the angle 1-0-1 in the development may be set off equal to $r/s \times 360^\circ$, where 'r' is the radius of the base and 's' is the slant height of the cone. The stretchout may now be divided into the same number of equal parts as in the T.V. making trials with the divider.

g) To obtain the true lengths of the elements for the development 1-A, 2-B, 3-C, etc., horizontal lines are projected from the points on the truncating line in the F.V. to any of the slant side. Compass is then set from point-P to each of these points in the F.V. and arcs are drawn from point-O on the development to intersect the corresponding elements.

h) The points obtained on the development are then connected by a smooth curve. The shaded part will then be the required development of the truncated cone. This development can be separated by cutting it from the sheet and the Left and the Right lines A-1 can be joined together by the tape. This will be a physical check for the accuracy of the development.

7.4.2 Development of a Square Right Pyramid

a) Top view and front view of the pyramid are drawn according to the required dimensions.

b) The pyramid is assumed to be enclosed within a cone having the same vertex and whose base is passing through the corners of the pyramid. This cone is shown in the two views by construction lines.

c) Development for the assumed cone is drawn and the four corners of the pyramid are shown on it as elements of the cone.

d) The points representing the base corners of the pyramid

are joined by straight lines in the development to get the pattern layout for the pyramid.

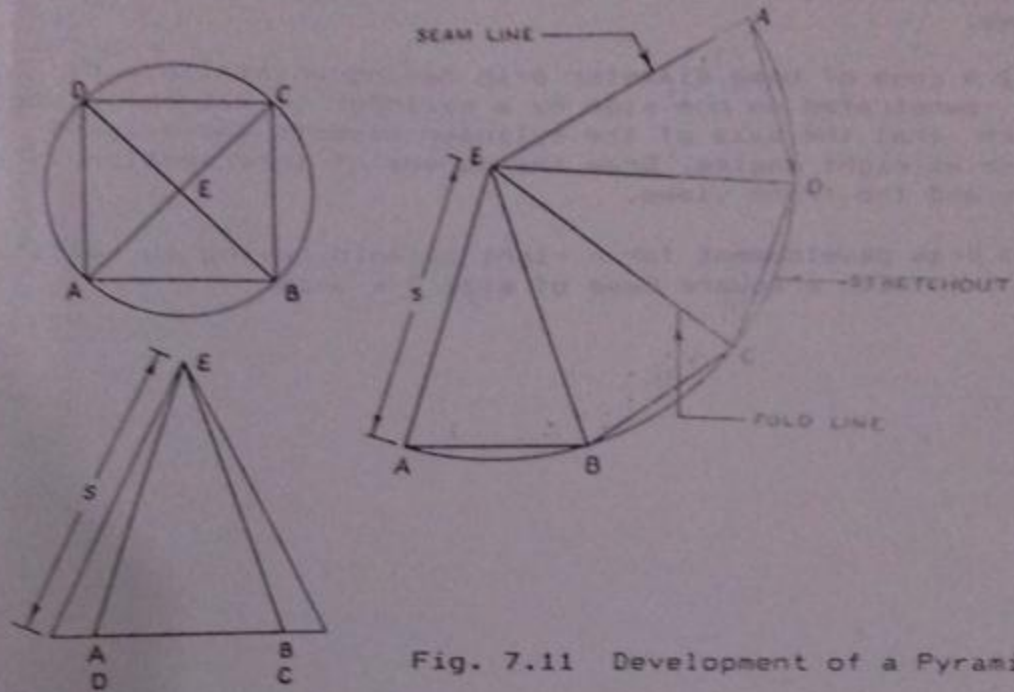

Fig. 7.11 Development of a Pyramid

PROBLEMS

7.1 A cone of base diameter 3-in and height 3.5-in is sectioned by a plane at an angle of 45° with the axis of the cone at a height of 2-in. Draw development for the truncated cone.

7.2 A cone of base diameter 6-in having an altitude of 5-in is penetrated on one side by a cylinder of 2.5-in diameter such that the axis of the cylinder bisects the axis of the cone at right angles. Draw the curves of intersection in the top and the front views.

7.3 Draw development for a right pyramid having an altitude of 6-in with a square base of size 5 x 5-in.

ABOUT THE AUTHOR

Zahid Ahmad Siddiqi, Ph.D., is Professor in Civil Engineering Department of University of Engineering and Technology, Lahore. He is author of previous edition of this book published in 1992 besides various editions of four more books on the subjects titled "Steel Structures", "LRFD Steel Design Aids", "Concrete Structures, Part-I" and "Concrete Structures, Part-II". He has teaching, research and practical design experience of almost 27 years. He has vast experience of teaching to Undergraduate and Graduate Students of Civil Engineering. He is actively involved in field design of sizeable concrete and steel structures.